

UNIT DIMENSIONS (inches)

DIMENSION	RSG1418S1E	RSG1424S1E	RSG1430S1E	RSG1436S1E	RSG1442S1E	RSG1448S1E	RSG1460S1E
HEIGHT	31	31	35	39	43	43	43
WIDTH	30 3/4	30 3/4	30 3/4	30 3/4	30 3/4	30 3/4	30 3/4
DEPTH	30 3/4	30 3/4	30 3/4	30 3/4	30 3/4	30 3/4	30 3/4
WEIGHT (lbs) NET/SHIPPING	162/171	166/175	171/180	176/185	181/190	220/232	223/235

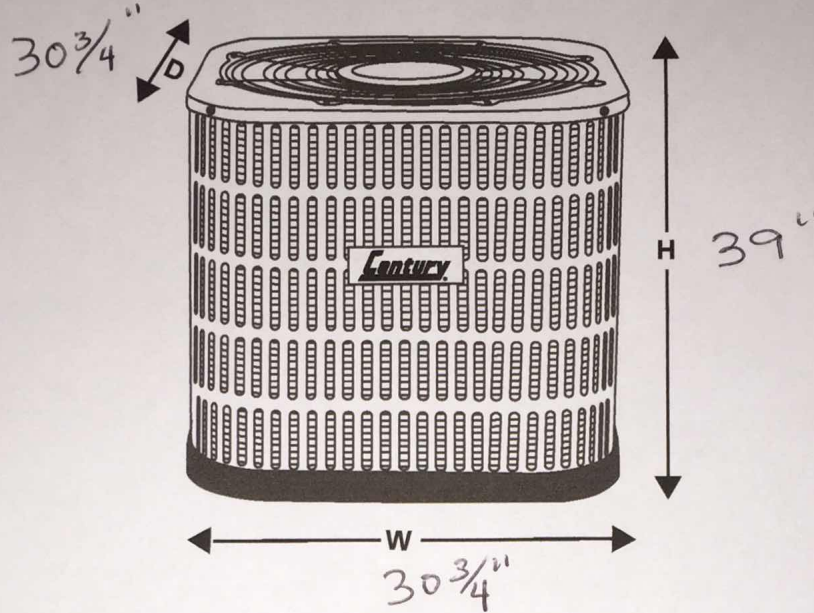

ACCESSORIES

PART NO.	DESCRIPTION
912933	Start Assist Kit—for extra starting torque when operating in low line voltage or high operating temperatures
920900	Extreme Wind Mounting Kit

X (1) Unit

Design, specifications, performance data and materials subject to change without notice.

HEAT CONTROLLER

1900 Wellworth Ave., Jackson MI 49203 • Ph. 517-787-2100 • www.heatcontroller.com

A **WATS** Company



DUCTLESS MINI-SPLIT SYSTEM



OZONE HOUSE

302

FOR SALE
BY OWNER
OZONE

