

**ANN ARBOR HISTORIC DISTRICT COMMISSION**

**Staff Report**

**ADDRESS:** 1137 Traver Road, Application Number HDC19-236

**DISTRICT:** Broadway Historic District

**REPORT DATE:** January 9, 2020

**REPORT PREPARED BY:** Jill Thacher, Historic Preservation Coordinator

**REVIEW COMMITTEE DATE:** Monday, January 6

**OWNER**

**APPLICANT**

**Name:** Elmer Martinez  
**Address:** 1137 Traver Road  
 Ann Arbor, MI 48105  
**Phone:** (734) 972-9510

Same

**BACKGROUND:** The Charles and Linda Waite House was constructed circa 1860 and is a contributing structure in the Broadway Historic District. The survey card and an article about the house that appeared in the winter 2015 Washtenaw County Historical Society Newsletter are attached to the application. The upright-and-wing house features a full-width front porch with Italianate brackets, wide board trim in the eaves, one-over-one windows, and a side wing with its own front porch. The side and rear walls, and the wing, are stucco.

In 2016, staff approved an application to remove the aluminum siding and stucco on the front of the house (see 2007 photo) and replace it with wood siding and trim to match the historic wood.

**LOCATION:** The site is located on the west side of Traver Road, south of Bowen and north of Moore.

**APPLICATION:** The applicant seeks HDC approval to selectively demolish and replace portions of the north, south, and east walls of the 2-story section of the house; reconstruct the north porch; and remove the non-historic stucco.

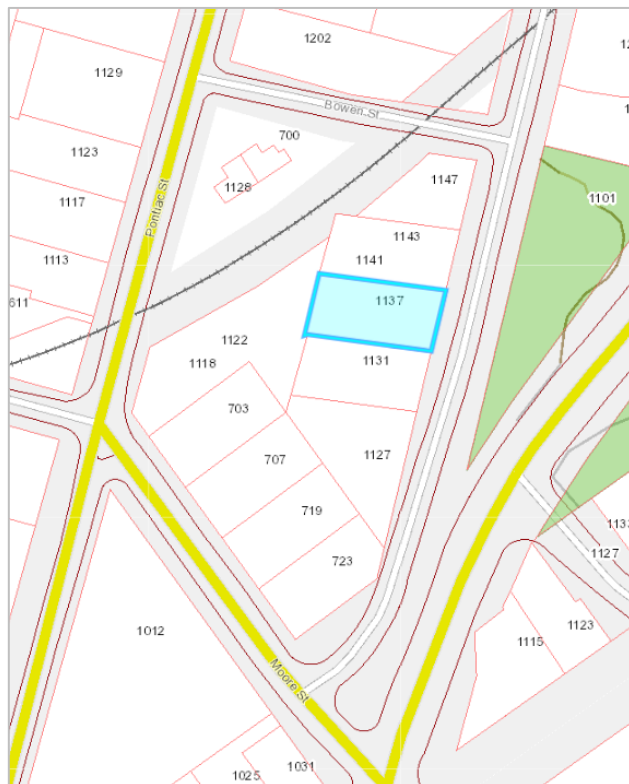

**APPLICABLE REGULATIONS:****From the Secretary of the Interior's Standards for Rehabilitation:**

- (2) The historic character of a property shall be retained and preserved. The removal of historic materials or alteration of features and spaces that characterize a property shall be avoided.
- (4) Changes to a property that have acquired historic significance in their own right will be retained and preserved.
- (5) Distinctive materials, features, finishes, and construction techniques or examples of craftsmanship that characterize a property will be preserved.
- (6) Deteriorated historic features will be repaired rather than replaced. Where the severity of deterioration requires replacement of a distinctive feature, the new feature will match the old in design, color, texture, and, where possible, materials. Replacement of missing features will be substantiated by documentary and physical evidence.
- (7) Chemical and physical treatments, if appropriate, will be undertaken using the gentlest means possible. Treatments that cause damage to historic materials will not be used.

**From the Secretary of the Interior's Guidelines for Rehabilitating Historic Buildings (other SOI Guidelines may also apply):****Building Site – Protect, Maintain***Recommended:*

- Evaluating the overall condition of the materials and features of the property to determine whether more than protection and maintenance are required, that is, if repairs to building and site features will be necessary.

**Building Site – Alterations, Additions***Not Recommended:*

- Introducing new construction onto the building site which is visually incompatible in terms of size, scale, design, materials, color and texture or which destroys historic relationships on the site.

**District or Neighborhood Setting – Protect, Maintain***Recommended:*

- Protecting and maintaining historic masonry, wood, architectural metals, stone, and plant features through appropriate treatments such as cleaning, rust removal, limited paint removal, and reapplication of protective coating systems; and pruning and vegetation management.

**District or Neighborhood Setting – Repair***Recommended:*

- Repairing features of the building and landscape by reinforcing the historic materials. Repair will also generally include the replacement in kind--or with a compatible substitute material--of those extensively deteriorated or missing parts of features when there are surviving prototypes, such as porch balustrades or paving materials.

*Not Recommended:*

- Replacing an entire feature of the building or landscape when repair of materials and limited replacement of deteriorated or missing parts are appropriate.
- Using a substitute material for the replacement part that does not convey the visual appearance of the surviving parts of the building or landscape, or that is physically, chemically, or ecologically incompatible.

**District or Neighborhood Setting – Replace***Recommended:*

- Replacing in kind an entire feature of the building or landscape that is too deteriorated to repair-- when the overall form and detailing are still evident --using the physical evidence as a model to guide the new work.
- If using the same kind of material is not technically or economically feasible, then a compatible substitute material may be considered.

**Entrances and Porches – Repair***Recommended:*

- Repairing entrances and porches by reinforcing the historic materials. Repair will also generally include the limited replacement in kind – with compatible substitute material – of those extensively deteriorated or missing parts of repeated features where there are surviving prototypes such as balustrades, cornices, entablatures, columns, sidelights, and stairs.

**Health and Safety***Not Recommended:*

- Making changes to historic buildings without first exploring equivalent health and safety systems, methods, or devices that may be less damaging to historic spaces, features, and finishes.

**Windows – Identify, Retain, Preserve***Recommended:*

- Conducting an in-depth survey of the conditions of existing windows early in rehabilitation planning so that repair and upgrading methods and possible replacement options can be fully explored.

**Wood – Identify, Retain, Preserve***Recommended:*

- Identifying, retaining, and preserving wood features that are important in defining the overall historic character of the building such as siding, cornices, brackets, window architraves, and doorway pediments; and their paints, finishes, and colors.

## Wood – Replace

### *Recommended:*

- Replacing in kind an entire wood feature that is too deteriorated to repair – if the overall form and detailing are still evident – using the physical evidence as a model to reproduce the feature. Examples of wood features include a cornice, entablature or balustrade.
- If using the same kind of material is not technically or economically feasible, then a compatible substitute material may be considered.

## STAFF FINDINGS:

1. Please read the Addenda to the HDC Application submitted by Black Raven Architects for an excellent description of existing conditions and proposed work. Staff has included in this staff report the most applicable guidelines from the *Secretary of the Interior's Guidelines for Rehabilitation*, because they are dictated by state enabling legislation. The architect has included standards and guidelines from the *Secretary of the Interior's Standards (and also Guidelines) for Reconstruction*. Staff believes this is helpful and applicable and should also be considered by the HDC since this is essentially a partial reconstruction project.
2. The structural deficiencies were identified when the homeowner had the inappropriate aluminum and stucco siding removed from the front elevation. Before new wood siding was installed, a visual structural assessment of the structural framing members was done by WJE, and conceptual recommendations were provided. Significant deterioration was found in the stone foundation and timber framing. The 2-story structure in front of the south wing is proposed to be reconstructed to match the existing or historic as closely as possible. Deviations are noted in the plans, some of which are summarized below by staff.
3. *Front Porch.* The proposal replaces the front porch with identified historic elements replicated (roof framing, trim, and brackets). The stucco porch wall would be removed. One addition is the porch column base shown on sheet G-001. The appearance of the original column bases is unknown, and this simple work is appropriate to the porch without being unduly ornate.
4. *Siding.* The reconstructed portion of the house is proposed to be wood lap sided to match the historic. The siding on both sides ends in the center of the façade, which seems visually abrupt on the drawings. Staff understands that this is an expensive project and the homeowner may wish to save the full siding replacement for a future expense, but the HDC will need to weigh whether this is appropriate.
5. *Foundation.* The existing crawlspace wall under the portion to be reconstructed is rubble and stone but is not visible above grade. Only a few inches are exposed between the dirt and siding. Sheet A-100 specifies “repair top of foundation” but does not specify how. In a previous conversation with staff, the architect mentioned replacing it with concrete. Because nothing will be visually lost by repairing the foundation with poured concrete, staff has no objections, if that is the plan.
6. *Windows.* The windows are not original or historic. The homeowner desires to reuse them if they survive demolition. If new windows are necessary or desired, a new

application for staff approval would be required.

7. Staff has had the advantage of speaking to the homeowner, architect, and structural engineer on multiple occasions about the project. Staff appreciates the care that has been taken with the proposal, and the credentials of the professionals hired to assist. Staff is generally in favor of the proposal, and looks forward to hearing discussion by the HDC.

**POSSIBLE MOTIONS:** (Note that the motion is only a suggestion. The Review Committee, consisting of staff and at least two Commissioners, will meet with the applicant on site and then make a recommendation at the meeting.)

I move that the Commission issue a certificate of appropriateness for the application at 1137 Traver Road, a contributing property in the Broadway Historic District, to selectively demolish and replace portions of the north, south, and east walls of the 2-story section of the house; reconstruct the north porch; and remove the non-historic stucco, as proposed. The work is compatible in exterior design, arrangement, texture, material and relationship to the rest of the building and the surrounding area and meets the *Ann Arbor Historic District Design Guidelines* and the *Secretary of the Interior's Standards for Rehabilitation and Guidelines for Rehabilitating Historic Buildings*, in particular standards 2, 4, 5, 6 and 7 and the guidelines for building site, neighborhood setting, health and safety, windows, and wood.

**ATTACHMENTS:** application, drawings, photos, structural engineer's report

1137 Traver Road (2007 survey photo)



1137 Traver Road (2019 application photo)





# HISTORIC DISTRICT COMMISSION

## PLANNING AND DEVELOPMENT SERVICES

City Hall: 301 E. Huron St. Ann Arbor, MI 48104-6120  
 Mailing: P.O. Box 8647, Ann Arbor, MI 48107-8647  
 Phone: 734.794.6265 ext. 42608 [ithacher@a2gov.org](mailto:ithacher@a2gov.org)  
 Fax: 734.994.8460

OFFICE USE ONLY	
Permit Number	HDC# _____
	BLDG# _____
DATE STAMP	

### APPLICATION MUST BE FILLED OUT COMPLETELY

#### PROPERTY LOCATION/OWNER INFORMATION

NAME OF PROPERTY OWNER <b>ELMER MARTINEZ</b>		HISTORIC DISTRICT <b>BROADWAY</b>	
PROPERTY ADDRESS <b>1137 TRAVER ROAD</b>			CITY <b>ANN ARBOR</b>
ZIPCODE <b>48105</b>	DAYTIME PHONE NUMBER <b>( 734 ) 972-9510</b>	EMAIL ADDRESS <b>elmermartinez123@att.net</b>	
PROPERTY OWNER'S ADDRESS (IF DIFFERENT FROM ABOVE)		CITY	STATE, ZIP

#### PROPERTY OWNER'S SIGNATURE

<b>SIGN HERE</b> →	<b>PRINT NAME</b> → <b>ELMER MARTINEZ</b>	<b>DATE</b> →
--------------------	---	---------------

#### APPLICANT INFORMATION

NAME OF APPLICANT <i>(IF DIFFERENT FROM ABOVE)</i>			
ADDRESS OF APPLICANT			CITY
STATE	ZIPCODE	PHONE / CELL # (       )	FAX No (       )
EMAIL ADDRESS			

#### APPLICANT'S SIGNATURE *(if different from Property Owner)*

<b>SIGN HERE</b> →	<b>PRINT NAME</b> → <b>X</b>	<b>DATE</b> →
--------------------	------------------------------	---------------

#### BUILDING USE – CHECK ALL THAT APPLY

<input checked="" type="checkbox"/> SINGLE FAMILY	<input type="checkbox"/> DUPLEX	<input type="checkbox"/> RENTAL	<input type="checkbox"/> MULTIPLE FAMILY	<input type="checkbox"/> COMMERCIAL	<input type="checkbox"/> INSTITUTIONAL
---	---------------------------------	---------------------------------	--	-------------------------------------	--

#### PROPOSED WORK

*Describe in detail each proposed exterior alteration, improvement and/or repair (use additional paper, if necessary).*

SELECTIVE DEMOLITION AND REPLACEMENT OF PORTIONS OF NORTH, SOUTH, AND EAST WALLS OF 2-STORY SECTION OF HOUSE. RECONSTRUCTION OF NORTH PORCH. REMOVAL OF FAILING AND HISTORICALLY INAPPROPRIATE STUCCO. NEW OR SALVAGED WINDOWS AND DOORS WILL REINSTALLED IN ORIGINAL LOCATIONS. NEW PAINT ON WALLS, WINDOWS, AND TRIM OVERALL. SEE ATTACHMENTS FOR PHOTOS AND DRAWINGS.

#### DESCRIBE CONDITIONS THAT JUSTIFY THE PROPOSED CHANGES:

A 2016 RENOVATION PROJECT UNCOVERED SEVERE DAMAGE TO THE HISTORIC POST AND BEAM STRUCTURE OF THE TWO-STORY SECTION OF THE HOUSE. DUE TO FINANCIAL CONSTRAINTS AT THE TIME, ONLY TEMPORARY REPAIRS WERE MADE AND THE EXPOSED STRUCTURE WAS RE-ENCLOSED. THE DAMAGE WAS DUE TO INSECT INFESTATION AND LONG-TERM WATER INFILTRATION. THE SILL BEAMS AND EASTERN COLUMNS WERE ROTTEN, MISSING SIGNIFICANT AREAS OF THE MEMBER CROSS SECTION, AND SEPARATED FROM THE SURROUNDING MEMBERS. THE STONE FOUNDATION WALLS HAVE LOST MOST OF THE MORTAR. THE FIRST AND SECOND FLOORS SLOPE DUE TO THE CONDITION OF THE SUPPORTING BEAMS. THE DAMAGED STRUCTURAL MEMBERS CANNOT BE SALVAGED, AND MUST BE REPAIRED IN THE MOST ECONOMICALLY FEASIBLE WAY POSSIBLE WHILE RETAINING THE OUTWARD APPEARANCE OF THE HOUSE. SEE ATTACHMENTS FOR A STRUCTURAL ENGINEERING REPORT.

For Further Assistance With Required Attachments, please visit [www.a2gov.org/hdc](http://www.a2gov.org/hdc)



# HISTORIC DISTRICT COMMISSION APPLICATION

## FEE CHART

DESCRIPTION	
STAFF REVIEW FEES	FEE
Application for Staff Approval	\$35.00
Work started without approvals	Additional \$50.00
HISTORIC DISTRICT COMMISSION FEES	
All other proposed work not listed below	\$100.00
Work started without approvals	Additional \$250.00
RESIDENTIAL – Single and 2-story Structure	
Addition: single story	\$300.00
Addition: taller than single story	\$550.00
New Structure - Accessory	\$100.00
New Structure – Principal	\$850.00
Replacement of single and 2-family window(s)	\$100 + \$25/window
COMMERCIAL – includes multi-family (3 or more unit) structures	
Additions	\$700.00
Replacement of multi-family and commercial window (s)	\$100 + \$50/window
Replacement of commercial storefront	\$250.00
DEMOLITION and RELOCATION	
Demolition of a contributing structure	\$1000.0
Demolition of a non-contributing structure	\$250.00
Relocation of a contributing structure	\$750.00
Relocation of a non-contributing structure	\$250.00

### FOR COMMISSION REVIEWS:

- Application withdrawals made before public notice is published will qualify for a 50% refund of the application fee.
- Application withdrawals made after public notice is sent but before the public hearing will qualify for a 25% refund of the application fee.

## INSTRUCTIONS FOR SUBMITTING APPLICATIONS

All HDC applications must be signed by the property owner and the applicant, if different, with the exception of staff approvals, which may be signed by only the applicant.

All completed HDC applications and their attachments may be submitted to Planning and Development Services by mail, in person (paper or digital), faxed, or via email to [building@a2gov.org](mailto:building@a2gov.org).

We accept CASH, CHECK, and all major credit cards. Checks should be made payable to “City of Ann Arbor”

HDC applications that are incomplete or not submitted with the required documentation or payment will not be processed or approved.

## APPLICATION EXPIRATION

HDC applications expire three (3) years after the date of approval.

## OFFICE USE ONLY

Date of Hearing:		
Action	<input type="checkbox"/> HDC COA	<input type="checkbox"/> HDC Denial
	<input type="checkbox"/> HDC NTP	<input type="checkbox"/> Staff COA
Staff Signature		
Comments		
Fee:	\$ _____	
Payment Type	<input type="checkbox"/> Check: # _____ <input type="checkbox"/> Cash <input type="checkbox"/> Credit Card	





ADDENDA TO HDC APPLICATION

## **MARTINEZ RESIDENCE STRUCTURAL REPAIRS AND RENOVATIONS**

1137 Traver Rd.  
Ann Arbor, Michigan 48105

December 19, 2019

137 N Main St • Adrian MI 49221  
517.577.6992

## Martinez Structural Repairs Narrative

### Existing Conditions

The Martinez Home at 1137 Traver Rd dates to 1866. The original house was of post-and-beam construction with a wood clapboard exterior. Dates of the subsequent additions at the rear of the house and the application of the stucco finish over the clapboard are unknown.

A 2016 project to remove failing stucco on the east and north walls of the two-story wing revealed severe damage to the post-and-beam structure. The stucco contributed to moisture infiltration and entrapment within the walls, resulting in rotting sill beams, posts, and columns. The corner columns on the east façade lost significant cross-sectional area. Boring insects attracted by the dark, moist conditions contributed to the damage. The water infiltration also eroded the mortar from the fieldstone foundation. The first and second floors slope due to the deteriorated supporting beams. Temporary bracing was installed at the first-floor interior to shore up the second-floor structure and the exterior walls were re-enclosed until a plan for long-term restoration could be developed and financed. Please see the attached structural engineering report for further details of the existing conditions.

The north porch is also in poor condition. The porch roof must be removed to access the damaged second-floor beam supporting the second-floor framing. The CMU porch wall is not original to the house, has large lateral cracks, and is unstable.

### Proposed Work

The work will focus on the north, east, and south faces of the two-story wing. New work will replace the damaged post-and-beam structure with modern platform framing and wood stud construction. The exterior appearance will be reconstructed to match the historic appearance as closely as possible. The owner would like to completely rebuild the north porch with a historically appropriate design for the bottom of the columns based on historic photographs of the porch and photographs of other local houses from the same era. The trim and decorative brackets will be used as templates for new brackets.

### Scope of Work

#### *DEMOLITION*

- Removal of the stucco finish.
- Removal and salvage of the windows and doors.
- Demolition of selected walls from the foundation to the roof.
- Demolition of the first and second-floor framing in the eastern portion of the building. Floor joists run from east to west, and tie into the east wall.
- Removal the fieldstone foundation under the east wall and portions of the north and south wall down to sound material. The stones will be salvaged for reuse.

#### *RECONSTRUCTION*

- Repair or replace the foundation as needed for the solid bearing of new walls.

## BLACK RAVEN ARCHITECTS

- Install new insulated stud walls at the exterior to enclose the building. The interior wall finish will be gypsum board.
- Install new or salvaged doors and windows at the previous locations.
- Install new exterior clapboard siding matching the exposure of the historic siding.
- Install new floor framing and finishes.
- Install a new concrete slab for the north porch.
- Reconstruct the north porch with new columns, roof, and decorative trim.
- Use the original porch brackets to recreate the profile for the new brackets.
- Prime and paint all new wood.
- Repoint the exposed interior basement walls.

### *Secretary of the Interior's Standards for Reconstruction*

The damaged structural members cannot be salvaged and must be repaired in the most economically feasible way possible while retaining the historic appearance of the house. Access to the framing requires selective permanent demolition of the surrounding exterior and interior finishes. Given these constraints, the proposed work falls under the U.S. Department of the Interior's Standards for Reconstruction.

Per Standard 1, the new work will accurately depict the external appearance of the house based on the existing conditions.

Per Standard 3, selective demolition will remove only the historic finishes required to uncover the damaged structure. Damaged structural members will be replaced as needed to ensure long-term stability. Windows and doors will be installed in the original locations. The spatial relationships will not be altered.

Per Standard 4, visible historic elements, such as column brackets, that must be replaced, will be duplicated using the existing elements as templates. The reconstruction will re-create the appearance of the non-surviving historical materials.

Per Standard 5, the underlying structural members that cannot be salvaged will be replaced with modern construction materials and techniques so that it can be clearly distinguished from the historic fabric at a future date. The owner will retain photographs and drawings documenting the work.

### *Secretary of the Interior's Standards for Rehabilitation*

The proposed new work complies with the Standards for Rehabilitation.

## BLACK RAVEN ARCHITECTS

### Historic Photographs (Dates Unknown)



Front Porch



Looking Northwest

**EXISTING  
CONDITION  
PHOTOGRAPHS**

**STRUCTURAL  
INVESTIGATION**

July 10, 2019

*Via E-mail at elmermartinez123@att.net*

Mr. Elmer Martinez  
1137 Traver Drive  
Ann Arbor, MI 48105

Re: 1137 Traver Drive, Ann Arbor, Michigan  
Reframing of East (Front) Wall of Home  
WJE No. WJE No. 2016.6288.1

Dear Mr. Martinez:

As requested, Wiss, Janney, Elstner Associates, Inc. (WJE) met with you at your home located at 1137 Traver Drive in Ann Arbor, Michigan to visually assess the condition of the framing exposed during a re-finishing effort of the exterior of the home. This letter summarizes our pertinent observations and provides conceptual recommendations for repair.

## **Project Description**

The home is a pre-Civil war era upright-and-wing with a reported construction date of the 1860s. The two-story home is located in one of the City of Ann Arbor historic districts. In 2016, during renovations to install more historically accurate siding, Mr. Michael Condon of Ypsilanti Restoration removed the existing stucco cladding and discovered that the wood structural framing had significantly deteriorated. Upon your request, on October 20, 2016, WJE visually assessed the structural framing members and provided verbal, conceptual recommendations. These recommendations included tasks that exceeded your available budget at the time and, as a result, the wall was re-covered, the second floor framing temporarily shored, and the overall project put on hold until this year when adequate funding is available.

Due to the house being located within the historic district, you have been in discussion with the Ann Arbor Historic District Commission (AAHDC) regarding the proposed work. The AAHDC has requested further information on the condition of the structure to warrant the proposed reframing the east wall of the house. This letter, with enclosed photographs, documents WJE's pertinent observations during the October 2016 site visit, and based on the assumption that the conditions have remained the same or worsened since, provides our conceptual recommendations for repair.

## **Observations**

The following are based on documentation of field notes and digital photographs collected during the October 2016 site visit. Since 2016, the structure has been re-enclosed, and is not currently visually accessible.

1. The exterior cladding had been removed on the east facade, exposing the exterior surface of the wood framed wall (Figure 1).
2. Stucco finish, observed on adjacent facades, was bulging outward near grade (Figure 2).
3. The exposed structure is a post and beam timber frame with diagonal braces at the corner posts.
  - a. There is a sill, or summer, beam in which the full 2 inch by 4 inch wall studs and full 2 inch by approximately 8 inch floor joists are let into.
  - b. There is an 8 inch by 8 inch timber beam at the second floor structure in which the wall studs and second floor joists are also let into.

4. The front porch structure had not been removed. The porch roof was observed to be bearing on a 2x ledger at the south wall of the home just above the second floor timber beam (Figure 3).
5. The interior surface of the east wall is finished with gypsum board and is water stained. The gypsum board is secured to dimension lumber furring strips located on the interior surface of the original wall studs (Figure 4).
6. The corner timber posts, summer beam and second floor perimeter timber beams had all deteriorated with significant section loss of the members.
  - a. Although full height of the corner posts, the deterioration was greatest at the bottom of the post (Figure 5). Fiberglass insulation was observed to be stuffed into a corner column.
  - b. Decay and insect infestation were prevalent in the summer beam (Figure 6).
  - c. On either side of the front door, isolated locations of rot and decay were observed at the second floor timber beam. The decay extended nearly the full depth and width of the beam at these locations (Figure 7).
7. The bottom of the studs, when probed with a pocket knife, was deteriorated where let into the summer beam.
8. The top of the second floor timber beam was observed to have rotated inward (or the bottom rotated outward) (Figure 3). The second floor joists were observed to have minimal bearing on the second floor timber beam and, thus, temporary shoring had been installed in the first floor living space.
9. The first floor joists, dimension lumber spanning east to west over a crawl space, are within eight inches of the earthen floor of the crawl space, especially at the east end of the span.
10. The stones of the perimeter foundation wall were observed to be loose, nearly dry-stacked (Figure 6). Mortar is missing in multiple joints on both the exterior and interior surfaces of the wall.

## Discussion

Both the stone foundation and the timber frame of this eastern portion of the house are in a significant state of deterioration. Water appears to have been collecting within the wall structure for an extended period of time. The exposure to the moisture has caused wood rot and a loss of integrity of the stone masonry foundation. Localized settlement of the structure has occurred, as evident with the displacement and bulging of the exterior stucco at the base of the wall.

The binder in the mortar of the stone foundation wall has been dissolved by the water migration through the wall. The loss of the binder creates an aggregate mortar or dust which falls from the joints between the stones and individual stones could be moved from the wall foundation, effectively rendering the stones as a dry-laid masonry wall. The mortar loss was prevalent on both the interior and exposed exterior surfaces of the wall indicating water exposure has occurred over a long period of time.

The interior and exterior finishes of the wood framed wall create a dark environment for the wood framing. If elevated moisture levels occur within this space, ideal conditions for wood boring insects to nest or feed on the timber framing are present. Long term exposure to moisture from nearby downspouts, porch roof flashing, cracks in the exterior stucco finish, and direct bearing to the masonry foundation contributed to the decay. Although samples were not taken for identification, the timber framing may be of a different species than the stud and joist framing of which the deterioration is not as severe. The timber species may be more susceptible to insect infestation and rot than the wood species of the studs and joists.

The modifications of the timber framing on the interior surface of the east wall indicate the deterioration was present when the first floor bathroom renovation occurred, as evident by the fiberglass insulation



stuffed into the corner timber column, missing corner braces between the columns and beams, and the installation of the 2x furring strips for the gypsum board attachment. If the temporary shoring was not installed, the furring strips would be supporting loads from the gable end wall and second floor joists.

## **Recommendations**

Based upon the extent of deterioration observed, the east wall structure requires full reinforcement or reconstruction. The north and south stone foundation walls of this area of the home should also be replaced or reconstructed. Consideration should be given to exposing the timber framing in the north and south walls to verify its condition.

The following summarizes three potential construction approaches for the east wall, with similar approaches assumed to apply to the north and south walls of this area of the home:

### ***Option 1: Select Demolition and Restructuring***

Maintain the geometry of the structure, but rebuild from the attic space down to new foundations. New foundations, new floors at both the first and second floor level, new walls (headers, doors, windows), and restructuring the porch would be anticipated.

Platform framing construction type detailing could be utilized to indicate that the structure had been altered within its lifetime. The existing attic and roof structures would be shored during this construction effort and tied into the new framing. Note, built-up columns will be required at the exterior corners to accept the timber framing elements of the north and south walls. The windows and doors may be able to be salvaged for replacement in the new wall construction. Other detailing trim pieces would be treated in a similar manner – to be salvaged for reuse with the re-structured framing. The use of treated lumber should be considered in the replacement approach.

The stone foundation could be reconstructed with concrete masonry units on a concrete strip foundation. A structural stone wythe on the exterior can be installed to maintain the original appearance of the foundation above grade.

### ***Option 2: Reconstruct in Like-Kind***

Remove and replace the heavy timbers to duplicate the more historically accurate structure of the residence. It should be noted that some of this detailing has been removed during the past bathroom renovation project. This option is not cost effective, constructability is a concern, and the costly historical structural items will be hidden behind finishes. Treatment of the timber sections for potential insect infestation is also difficult to achieve due to the member sizes.

The stone foundation requires reconstruction. A mortar for use against grade and for stone masonry should be considered.

### ***Option 3: Reinforcement of the Existing Structure***

Keep the degraded historic structure in place and add new materials alongside, or sistered, to reinforce the existing structure. The stone foundation will still require replacement or rebuilding; thus, shoring of the existing structure will still be required, and may be problematic due to its existing condition. In addition, the ‘old house character’ of dips and slopes in the floors may become problematic with alignment with new lumber. Selective demolition of the original timber beams will be required to assemble the new platform

style framing details. Detailing at corners and edges will require extra consideration to ensure the finish materials are secured to sound and anchored wood members. A qualified exterminator should evaluate the existing framing for active insect activity, and appropriate treatments applied. New lumber should be treated lumber. This approach will be cumbersome for the contractor, but will maintain the historic materials, if that is an important design criteria.

### **Summary**

Of the options presented, WJE recommends Option 1, a full restructuring with new materials and detailing respective of today's carpentry and masonry techniques. Although it would be ideal if the original timber framing could be salvaged or repaired, the existing condition of the timber framing does not practically allow for this approach. Replacement of the timber framing only is difficult to achieve both in design of the member connections and constructability. Reconstruction of the stone foundation is possible, but it is labor intensive and costly.

Reconstruction with modern materials and detailing allows the historic geometry to be maintained, historic based finishes be re-applied to the interior and exterior surfaces, ensures adequate structural integrity into the future, and represents the current story within the life of this historic structure.

Continued maintenance of the gutters and downspouts, maintenance of the exterior cladding, and providing adequate flashing of the porch roof to limit water infiltration into the wall structure is critical in the life of the restructured wall, regardless of which option above is considered.

### **Closing**

As stated above, the observations and recommendations made within this letter are based on a limited visual assessment completed three years ago. The decay and deterioration of the timber framing and stone foundation will not have improved within the last three years and may have worsened. Once the framing is re-exposed, the condition of the framing and foundation systems in this eastern wing of the house should be verified by a qualified contractor or professional engineer.

The recommendations provided herein allow the historic integrity of the architectural features of the home be replaced, but the structural system, hidden behind the architectural finishes, can represent this significant time in the life of the building. Should you have any questions on the above, or would like to discuss this further, I can be reached at 248-593-0900 or [cearly@wje.com](mailto:cearly@wje.com).

Sincerely,

**WISS, JANNEY, ELSTNER ASSOCIATES, INC.**



Cheryl Early, P.E.  
Senior Associate

Enclosures: *Figures Figure 1 through 7*



*Figure 1. Exterior cladding removed in 2016 exposing wood framing of east wall of home. Arrow is pointing to water staining on the backside of the gypsum board interior finish.*



*Figure 2. Bulging of exterior stucco finish along adjacent wall to east wall of home.*



*Figure 3. Rotated second floor timber beam. Note 2x ledger for porch roof rafters secured to east wall timber framing.*



*Figure 4. Newer wood 2x furring members added to original wall framing.*



*Figure 5. Decayed timber corner column; yellow lines indicate approximate original section size.*



*Figure 6. Loose stone and missing mortar of stone foundation. Decayed summer beam atop stone foundation. Yellow lines indicate approximate original section depth.*



*Figure 7. Decay of second floor perimeter timber beam. Arrow pointing to edge of second floor decking.*

**RESUMES**



**BRENDA RIGDON, AIA, LEED BD+C**  
Principal, Black Raven Architects  
137 N. Main Street  
Adrian, Michigan 49221  
brenda@blackravenarchitects.com  
734.717.2753

#### **REGISTRATION**

State of Michigan License Number 1301049427

#### **OVERVIEW**

Brenda Rigdon founded Black Raven Architects after twenty years of experience as an architect, primarily in historic preservation and the adaptive reuse of existing buildings. Her work includes field documentation, research, design, and preparation of construction documents and specifications. She works with clients, consultants, building code officials, and contractors to provide the best design solutions for large or small redevelopment projects.

#### **SELECT PROJECTS**

##### **Chaloner & Co. / Chaloner's Cigar Lounge**

108-110 W. Maumee Street, Adrian, Michigan

Completed: February 2019. Construction Cost: \$5 million.

##### *Project Manager and Historic Preservation Consultant*

Chaloner & Co., a tobacconist and magazine shop, was a legendary downtown Adrian destination for 141 years until it closed in 2015. A group of local investors purchased the building at 108 W. Maumee St. in the winter of 2017. Their goals were to restore the exterior and interior, retain the atmosphere of the original shop as a community gathering place, and bring the retailing up to modern standards to help to ensure the future of the business and the building. They also purchased an adjacent building at 110 W. Maumee St. to combine the upper floors. The storefronts and cornices of both buildings were reconstructed based on historic photographs from the 1870s. Deteriorated or inappropriate windows were replaced with units matching the sight-lines and design of the original windows. The new storefronts incorporate operable awnings as shown in the historical photos. The brick facade was cleaned and repointed. Accent lighting and flag poles were added. The original "Chaloner & Co" metal sign and a neon window sign were salvaged and reconditioned.

The interiors were completely renovated. The tin ceiling of the first-floor retail space was replicated. The plaster was removed to expose the underlying brick. Where possible, the original wood floors were restored. New wood trim matching the original profiles was installed throughout. Custom cabinetry, wainscoting, and coffered wood ceilings show off the contractor's carpentry skills. A LULA-style elevator was installed to provide ADA-compliant access to the upper floors, and a second stairway was installed on the 110 W. Maumee side of the building to meet egress requirements. All mechanical and electrical systems are new.

The first-floor retail space of Chaloner & Co. includes a large custom-built, walk-in cigar humidor. In keeping with the original Chaloner's tradition, the store also sells popcorn, nuts, bulk "vintage" candy, and bottled sodas. The first-floor tenant of 110 W. Maumee is Copper House Coffee Company, a coffee shop and gourmet coffee roasting company that opened in June



2019. The upper floor cigar lounges offer lounge-style seating, a cocktail bar, pool table, atrium, and private cigar lockers. New openings were created in the brick wall dividing the two buildings to expand the floor area and create an open flow between the lounges and other areas while maintaining a sense of distinct rooms. On the third floor, the opening between the pool room and the lounge was built out with custom wainscoting to meet the face of the cigar lockers and create a window nook. The rear portion of the third-floor roof on the 110 W. Maumee side was in very poor condition and required a complete replacement. Instead, the roof was removed and replaced by a large skylight the full width of the building. Water features and wall tile hide existing CMU infill. The atrium is a non-smoking area and is available to the patrons of the first-floor coffee shop.

### **Copper House Coffee Company**

110 W. Maumee Street, Adrian, Michigan

Completed: June 2019. Construction Cost: \$300,000

#### *Project Manager and Historic Preservation Consultant*

The Copper House Coffee Company is part of the renovation of 108-110 W. Maumee initiated by local investors as a way of attracting and retaining high-value employees to their community by providing amenities enjoyed in larger cities. The cafe provides downtown Adrian with a much-needed coffee shop and offers gourmet house-roasted coffee beans for sale and on-line. Historic photographs guided the façade renovation. A folding door-wall was incorporated into the new storefront to allow for a European-style café experience. The hand-crafted copper coffee roaster is featured behind another door-wall to allow patrons to watch the roasting process and tour the facility.

### **The YPSI: Ypsilanti Performance Space**

218 N. Adams Street, Ypsilanti, Michigan

#### *Principal in Charge*

Preparation of a Federal Historic Tax Credit Application and renovation drawings for the adaptive reuse of the 130-year-old First Congregational United Church of Christ in downtown Ypsilanti. The 130-year-old First Congregational United Church of Christ in downtown Ypsilanti had been on the market for over ten years, as the shrinking and aging congregation found maintenance increasingly difficult and unaffordable. Fortunately, the building is in sound condition and retains original stained-glass windows, lighting fixtures, and other furnishings. It was purchased by local preservationists Steve Pierce and Maggie Brandt in the spring of 2018. They are undertaking a long-term restoration of the building. The church re-opened on May 16, 2019, as a performance and event space, modeled on The Old Church Concert Hall in Portland, Oregon.

### **Rice & Barley Taphouse**

101 E. Maumee St., Adrian, Michigan

#### *Principal in Charge*

The prominent first-floor corner of the Strongback Development at 101 E. Maumee St. was built out as a Pan-Asian restaurant by the owners of a local craft brewery and distillery. Restaurant design, particularly in an existing historic space, presents many challenges. This requires working closely with the owners to develop equipment layouts, mechanical, and electrical systems. The resulting space is both functionally efficient and creatively furnished, offering an exciting new eatery for downtown Adrian. Completed Fall 2018.

## **WORK UNDER PREVIOUS EMPLOYERS**

### **Strongback Properties**

101-111 E. Maumee St., Adrian, Michigan  
Completed: September 2017. Construction Cost: \$5.5 million

*Project Architect and Historic Preservation Consultant*

This \$4.5 million project, at the historic Four Corners of downtown Adrian, completely renovated the Underwood Block and two adjacent historic buildings. The first floors of the buildings house a restaurant, real estate office, and barber. The upper floors were connected and converted to 17 apartments. A variety of MEDC and local incentives, and therefore design requirements, were involved in the financing package that made this development possible.

**Capital Senior Living**

Dallas, Texas

Project Architect for renovations to multiple senior living facilities in Ohio and Indiana. Capital Senior provides independent, assisted living, and memory care residences. Projects included remodeling of tenant apartments, creating new gathering spaces such as pubs, coffee shops, and fitness centers, and exterior renovations. (Adrian Design Group)

**Potter Stewart U.S. Courthouse**

Cincinnati, OH

Project Architect in charge of exterior work, including masonry and window restoration, roof replacement, and boiler replacement as part of \$30 million renovations and modernization of a historic 1936 courthouse. The courthouse is nine stories and approximately 500,000 SF with some 900 window units. Responsible for restoration design, construction documents, field surveys, and coordinating specifications and consultants. (Quinn Evans Architects)

**College for Creative Studies Administration and Student Services Building**

Detroit, Michigan

Designed, prepared construction documents, and provided construction oversight for a \$3.2 million project to renovate two derelict historic homes at Ferry and John R for use as offices. The homes were connected by a new three-story elevator tower to provide handicapped accessibility and a link between the two buildings. The combined buildings housed the CCS boardroom, executive offices, and the admissions department. The project received a Detroit Tri-UMPH Award 2002 from the Detroit Historic District Commission. (Elisabeth Knibbe Architects)

**Detroit Charter Schools 2002-3**

Detroit, Michigan

Woodward Academy and Hope Charter School involved the phased renovation of existing facilities, including requirements for meeting the American with Disabilities Act, updates to building codes, and working with state licensing requirements. The Woodward Academy was a former medical facility, and the Hope Academy was in a historic school building. Each presents the common challenges of converting obsolete buildings into a modern, functional, and aesthetically pleasing learning environments. (Elisabeth Knibbe Architects)

**Historic Tax Credit Certification Projects, Various Michigan Locations**

Involved in field documentation and preparation of tax credit applications on the following: Casa Del Rey, Pontiac; Burroughs Graphics Arts Building, New Amsterdam Historic District, Detroit; Calle Brothers Building, New Amsterdam Historic District, Detroit; Stroh Tower (Grand Park Centre), Grand Circus Park Historic District, Detroit. (Elisabeth Knibbe Architects)

## **National Register of Historic Places Nominations**

Argonaut Building, Detroit, MI, author.  
Sugar Hill Historic District, Detroit, MI, editor.  
(Elisabeth Knibbe Architects)

## **National Park Service Indefinite Quantity Contract, Midwest Region**

Researched, authored, and managed multiple Historic Structures Reports for projects within the Midwest Region of the National Park Service. These reports involved research of the building and site history, assessment of cultural significance, assessment of existing conditions, development of recommended treatment options, and preparation of cost estimates. The projects had in common the challenge of providing handicapped access to the sites in a sensitive manner and the introduction of new mechanical and electrical systems with minimal disruption to the historic building fabric. (Quinn Evans Architects)

## **EDUCATION**

Bachelor of Fine Arts, University of Michigan, 1985  
Master of Architecture, University of Michigan, 1997

## **PROFESSIONAL AFFILIATIONS**

American Institute of Architects  
LEED-AP BD+D  
NCARB  
National Trust for Historic Preservation  
Michigan Historic Preservation Network

## **CIVIC AFFILIATIONS**

Greater Ann Arbor Quilt Guild, Vice President of Programs  
Adrian Historic District Commission, Adrian MI  
Lifetime Member and Volunteer, Lenawee County Historical Museum  
Board of Directors, Adrian Symphony Orchestra, Adrian MI  
Board of Directors, Samaritis Affordable Living Community, Adrian MI  
Volunteer, Art-A-Licious Fine Arts Festival, Adrian MI

## **PRESENTATIONS AND EXHIBITS**

"Chaloner & Co.: Proactive Preservation"  
Lenawee County Planning Commission Annual Dinner, June 20, 2019

"A Sense of Place: The Croswell Opera House"  
Michigan Historic Preservation Network Conference, May 2014

"HomeCraft: Historic Quilts, Needlework, and Decorative Arts of Lenawee County"  
Exhibit Co-curator, Lenawee County Historical Museum, 2015



## PERSONNEL QUALIFICATIONS

### Cheryl L. Early | Senior Associate



#### EDUCATION

- Michigan Technological University
  - Bachelor of Science, Civil Engineering, Structural and Transportation Emphasis, 1996

#### PRACTICE AREAS

- Structural Analysis
- Historic Preservation
- Structural Design
- Historic Structures Reports
- Failure/Damage Investigations

#### REGISTRATIONS

- Professional Engineer in ID, IN, MI, and WI

#### PROFESSIONAL AFFILIATIONS

- American Society of Civil Engineers
- Chi Epsilon Civil Engineering Honor Society
- Association of Preservation Technology Eastern Great Lakes Region Chapter President
- Michigan Historic Preservation Network
- National Trust for Historic Preservation

#### CONTACT

cearly@wje.com  
248.593.0900  
www.wje.com

#### EXPERIENCE

Cheryl Early joined WJE in 2016 with more than twenty years of experience in structural engineering, structural design and historic preservation. Leveraging her practical knowledge of vintage construction detailing with her sound understanding of engineering principles, she is able to creatively solve complex or unique structural issues for new buildings and renovation projects.

Ms. Early is experienced with many structural materials including concrete, masonry, steel and wood, as well as aluminum, carbon fiber, autoclaved aerated concrete (AAC), and historic materials. She has worked with structures built in the 1800s through new construction, providing a range of services from feasibility studies through construction administration tasks. Ms. Early has provided consulting and design services for numerous building types including monuments, residential, commercial, educational, healthcare, governmental, pedestrian bridges, and mixed use properties.

#### REPRESENTATIVE PROJECTS

##### Structural Analysis

- Starkweather Elementary School - Plymouth, MI: 1930s cast-in-place concrete floor and masonry structure analysis, construction documents and consulting
- Chelsea Milling Company (Jiffy Mix) - Chelsea, MI: Wood, masonry, steel, and concrete structural alterations and assessments\*
- Harry S Truman Home - Independence, MO: Review and reinforcement of private home for museum use\*

##### Historic Preservation

- Belle Isle Park - Detroit, MI: Assessment and repair design for five prominent buildings
- Detroit Institute of Arts Film Theater - Detroit, MI: Renovation of the grand stair and arcade renovation\*
- Traverse City Opera House - Traverse City, MI: Restoration of the opera house's block of buildings\*
- Ulysses S. Grant National Historic Site - St. Louis, MO: Relocation and restoration of timber-framed barn connected to new visitor center and office building\*

- Brown v. Board of Education Monroe School - Topeka, KS: Preservation of concrete structure and damaged roof repair\*
- Jackson Art Lofts - Jackson, MI: Adaptive reuse of the state's first prison and adjacent buildings into residential and artist spaces\*

##### Structural Design

- Woodward Willis Building - Detroit, MI: New steel moment frame structure with composite concrete floor\*
- DNR Maintenance Garage, Muskallonge Lake State Park - Newberry, MI: New wood-framed maintenance garage\*
- 52, 71, and 74 East Garfield - Detroit, MI: Assessment and rehabilitation of masonry and wood-framed structures\*
- Chelsea Medical Office Building - Chelsea, MI: New multistory, steel moment frame with composite concrete floor structure\*

##### Historic Structures Reports

- Michigan Offshore Lights - Upper Michigan: Thunder Bay Island, Manitou Island, Gull Rock and Stannard Rock
- Keweenaw National Historical Park - Calumet, MI: Historic structures report and structural consulting for several buildings\*
- Tallgrass National Prairie Preserve - Strong City, KS: Structural portions of conditions assessment report on more than twenty-five National Park structures and historic structures report on the main house\*
- Fort Gratiot Lighthouse - Port Huron, MI: Historic structures report and exterior rehabilitation\*

##### Failure/Damage Investigations

- Iroquois Bike Shop - Mackinac Island, MI: Investigated condition of building and exposed timber piles\*
- City Hall - Marine City, MI: Investigated wall failure; structural design, documentation\*
- Amtrak Passenger Stations - Jackson and Niles, MI: Repair of multiple structures\*
- Irish Hills Twin Towers - Onsted, MI: Field evaluation\*
- Fenton Seminary - Fenton, MI: Assessment of wall collapse\*

\*Indicates with previous firms

**SECRETARY OF  
THE INTERIOR'S  
STANDARDS FOR  
RECONSTRUCTION**

# Technical Preservation Services

National Park Service  
U.S. Department of the Interior



[About](#)

**[The Standards](#)**

[Tax Incentives](#)

[How To Preserve](#)

[Sustainability](#)

[Historic Surplus Property](#)

[Education & Training](#)

[Hot Topics](#) ▼

[Home](#) > [The Standards](#) > [Four Approaches to the Treatment of Historic Properties](#) > [Reconstruction](#)



## Reconstruction

**Reconstruction** is defined as the act or process of depicting, by means of new construction, the form, features, and detailing of a non-surviving site, landscape, building, structure, or object for the purpose of replicating its appearance at a specific period of time and in its historic location.

[Standards for Preservation](#)

[Standards for Rehabilitation](#)

[Standards for Rehabilitation](#)  
(for historic tax credit projects)

[Standards for Restoration](#)

[Standards for Reconstruction](#)

[History of the Standards](#)

[Guidelines for the Treatment of Historic Properties](#)

[Guidelines for the Treatment of Cultural Landscapes](#)

[Guidelines for Rehabilitating Historic Buildings](#)

[Guidelines on Sustainability](#)

[Guidelines on Flood Adaptation for Rehabilitating Historic Buildings](#)

## Standards for Reconstruction

The Standards will be applied taking into consideration the economic and technical feasibility of each project.

1. Reconstruction will be used to depict vanished or non-surviving portions of a property when documentary and physical evidence is available to permit accurate reconstruction with minimal conjecture, and such reconstruction is essential to the public understanding of the property.
2. Reconstruction of a landscape, building, structure or object in its historic location will be preceded by a thorough archeological investigation to identify and evaluate those features and artifacts that are essential to an accurate reconstruction. If such resources must be disturbed, mitigation measures will be undertaken.
3. Reconstruction will include measures to preserve any remaining historic materials, features and spatial relationships.
4. Reconstruction will be based on the accurate duplication of historic features and elements substantiated by documentary or physical evidence rather than on conjectural designs or the availability of different features from other historic properties. A reconstructed property will re-create the appearance of the non-surviving historic property in materials, design, color and texture.
5. A reconstruction will be clearly identified as a contemporary re-creation.
6. Designs that were never executed historically will not be constructed.

## Reconstruction as a treatment

When a contemporary depiction is required to understand and interpret a property's historic value (including the re-creation of missing components in a historic district or site); when no other property with the same associative value has survived; and when sufficient historical documentation exists to ensure an accurate reproduction, Reconstruction may be considered as a treatment.

The [Guidelines for the Treatment of Historic Properties](#) illustrate the practical application of these treatment standards to historic properties.

The [Guidelines for the Treatment of Cultural Landscapes](#) apply these treatment

# MARTINEZ RESIDENCE

1137 TRAVER ROAD  
ANN ARBOR MI 48105

## PROJECT DESCRIPTION

THIS PROJECT INVOLVES STRUCTURAL REPAIRS TO THE TWO-STORY SECTION OF A HISTORIC HOME. THE EASTERN PORTION OF THE TWO-STORY WING HAS SIGNIFICANT WATER DAMAGE TO THE UNDERLYING POST-AND-BEAM FRAMING. NEW WORK WILL REPLACE THE DAMAGED STRUCTURE WITH MODERN PLATFORM FRAMING AND WOOD STUD CONSTRUCTION. THE EXTERIOR APPEARANCE WILL BE RECONSTRUCTED TO MATCH THE HISTORICAL APPEARANCE AS CLOSELY AS POSSIBLE.

### SCOPE OF WORK

#### DEMOLITION

- REMOVAL OF THE STUCCO FINISH.
- REMOVAL AND SALVAGE OF THE WINDOWS AND DOORS.
- DEMOLITION OF SELECTED WALLS FROM THE FOUNDATION TO THE ROOF.
- DEMOLITION OF THE FIRST AND SECOND FLOOR FRAMING IN THE EASTERN PORTION OF THE BUILDING. RUN FROM EAST TO WEST, AND TIE INTO THE EAST WALL.
- REMOVAL THE FIELDSTONE FOUNDATION UNDER THE EAST WALL AND PORTIONS OF THE NORTH AND SOUTH WALL DOWN TO SOUND MATERIAL. THE STONES WILL BE SALVAGED FOR REUSE.

#### RECONSTRUCTION

- REPAIR OR REPLACE THE FOUNDATION AS NEEDED FOR SOLID BEARING OF NEW WALLS.
- INSTALL NEW INSULATED STUD WALLS AT THE EXTERIOR TO ENCLOSE THE BUILDING. THE INTERIOR WALL FINISH WILL BE GYPSUM BOARD.
- INSTALL NEW OR SALVAGED DOORS AND WINDOWS AT THE PREVIOUS LOCATIONS.
- INSTALL NEW EXTERIOR CLAPBOARD SIDING MATCHING THE EXPOSURE OF THE HISTORIC SIDING.
- INSTALL NEW FLOOR FRAMING AND FINISHES.
- INSTALL A NEW CONCRETE SLAB FOR THE NORTH PORCH.
- RECONSTRUCT THE NORTH PORCH WITH NEW COLUMNS, ROOF, AND DECORATIVE TRIM.
- USE THE ORIGINAL PORCH BRACKETS TO RECREATE THE PROFILE FOR THE NEW BRACKETS.
- PRIME AND PAINT ALL NEW WOOD.
- REPOINT THE EXPOSED INTERIOR BASEMENT WALLS.



## APPLICABLE CODES

**BUILDING:** 2015 MICHIGAN RESIDENTIAL CODE  
2015 MICHIGAN REHABILITATION CODE FOR EXISTING BUILDINGS  
**MECHANICAL:** 2015 MICHIGAN MECHANICAL CODE  
**PLUMBING:** 2015 MICHIGAN PLUMBING CODE  
**ELECTRICAL:** 2017 NATIONAL ELECTRIC CODE  
**ENERGY:** 2015 MICHIGAN UNIFORM ENERGY CODE INCLUDING ASHRAE 90.1-2013  
**FIRE:** 2018 INTERNATIONAL FIRE CODE

### CODE REVIEW SUMMARY

**USE GROUP:** R-3

**FIRE PROTECTION:** NOT SUPPRESSED

### FIRE RESISTANCE RATINGS

STRUCTURAL FRAME	1 HOUR	TABLE 601
FLOOR CONSTRUCTION	0 HOUR	TABLE 601
ROOF CONSTRUCTION	0 HOUR	TABLE 601

<b>EXTERIOR WALLS</b>		
LOAD BEARING	0 HOUR	TABLE 601
NON-LOAD BEARING	0 HOUR	TABLE 601

<b>INTERIOR WALLS</b>		
LOAD BEARING	0 HOUR	TABLE 601
NON-LOADBEARING	0 HOUR	TABLE 601

**TYPE OF CONSTRUCTION:** V-B

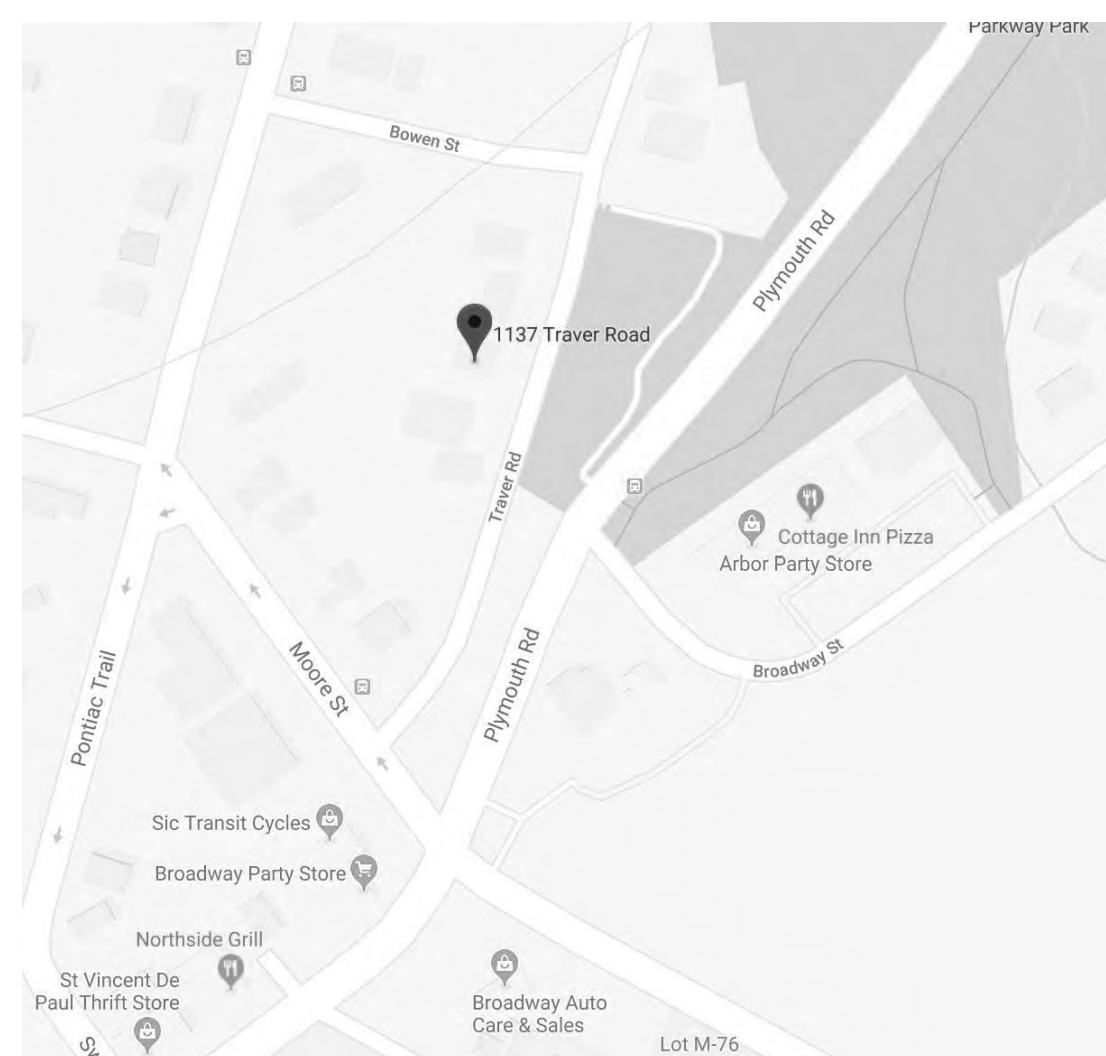

PROJECT SITE

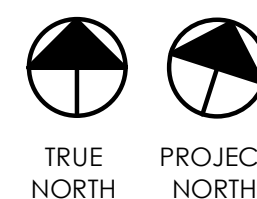

**ARCHITECT:**  
BRENDA RIGDON, AIA, LEED-AP BD&C  
BLACK RAVEN ARCHITECTS LLC  
137 N MAIN ST  
ADRIAN MI 49221  
517.577.6992 • 734.717.2753  
brenda@blackravenarchitects.com

**OWNER:**  
ELMER MARTINEZ  
1137 TRAVER ROAD  
ANN ARBOR MI 48105  
734.972.9510  
elmermartinez123@att.net

**CONTRACTOR:**  
MICHAEL F. CONDON  
YPSILANTI RESTORATION LLC  
734.485.2653 • 734.262.2328  
mike@ypsilantirestoration.com

DRAWING INDEX					
12-18-19 HDC APPLICATION	12-11-19 OWNER REVIEW	11-18-19 HDC PREVIEW	10-29-19 REVIEW	SHEET #	SHEET NAME
•	•	•	•	T-001	Project Information
•	•	•	•	G-001	General Information
•	•	•	•	AX100	Existing Basement Plan
•	•	•	•	AX101	Existing First Floor Plan
•	•	•	•	AX102	Existing Second Floor Plan
•	•	•	•	AX103	Existing Roof Plan
•	•	•	•	AX200	Existing Elevations
•	•	•	•	AD100	Basement Demolition Plan
•	•	•	•	AD101	First Floor Demolition Plan
•	•	•	•	AD102	Second Floor Demolition Plan
•	•	•	•	AD103	Roof Demolition Plan
•	•	•	•	A-100	Basement Floor Plan
•	•	•	•	A-101	First Floor Plan
•	•	•	•	A-102	Second Floor Plan
•	•	•	•	A-103	Roof Plan
•	•	•	•	A-200	Elevations



137 N MAIN ST • ADRIAN MI 49221  
517.577.6992  
www.blackravenarchitects.com

SEALED BY:

**NOT FOR CONSTRUCTION**

CONSULTANT

ISSUED		
#	DATE	DESCRIPTION
A	10-24-19	REVIEW
B	11-18-19	HDC PREVIEW
C	12-11-19	OWNER REVIEW
D	12-18-19	HDC APPLICATION

**Martinez Residence**  
1137 Traver Rd., Ann Arbor, 48105

Project Information

PROJECT NUMBER:  
19.41

DRAWN BY:  
BLR

ARCHITECT:  
BLR

SHEET NUMBER:  
T-001



REPLICATE PORCH ROOF FRAMING, TRIM, AND DECORATIVE BRACKETS BASED ON EXISTING ELEMENTS

**1** PORCH COLUMN HEAD  
1/8" = 1'-0"

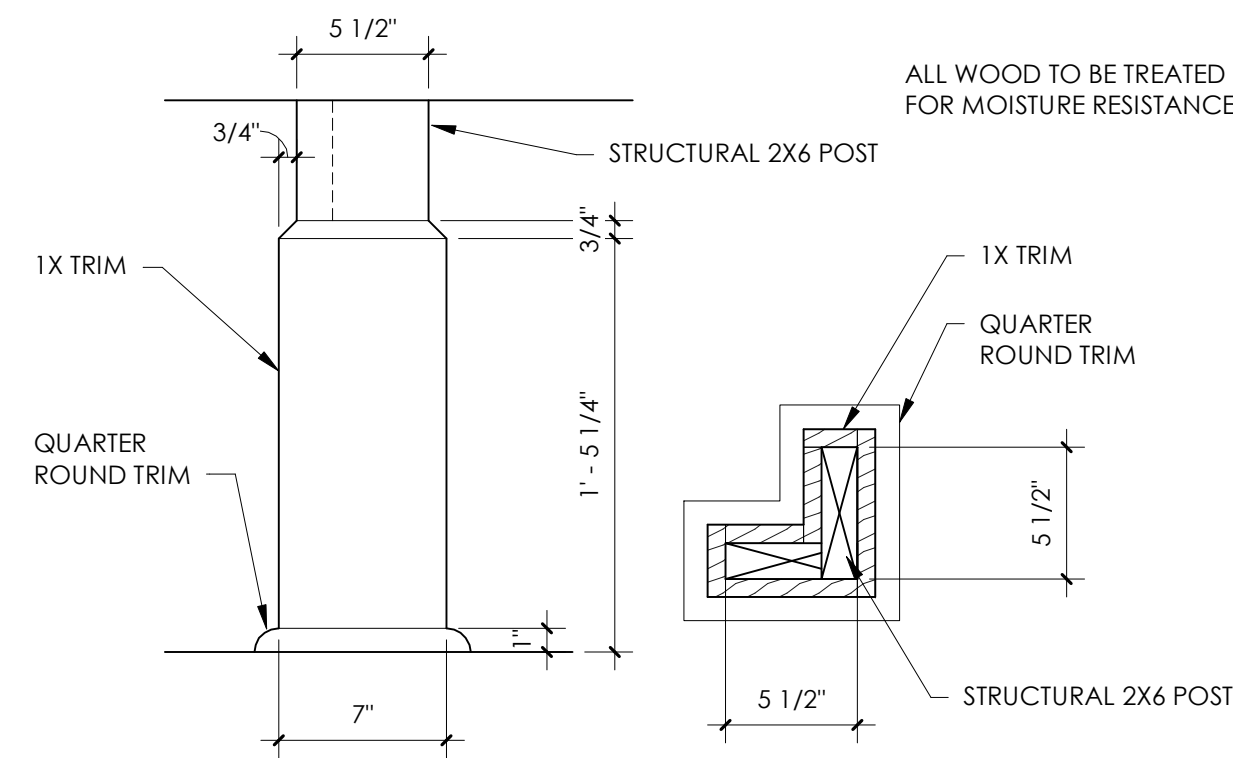

**2** PORCH COLUMN BASE  
1 1/2" = 1'-0"

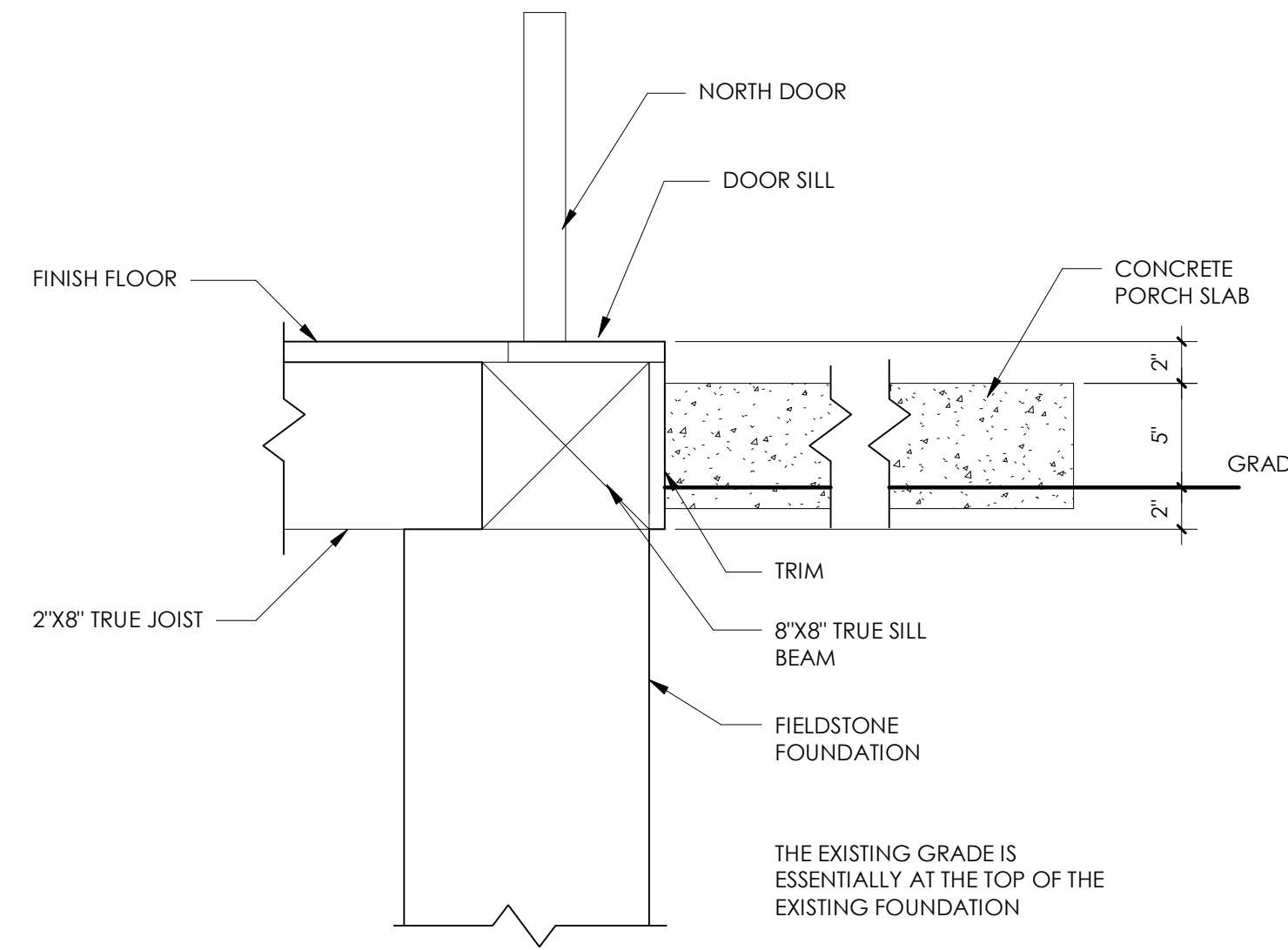

**EXISTING FLOOR SILL DETAIL**  
1 1/2" = 1'-0"

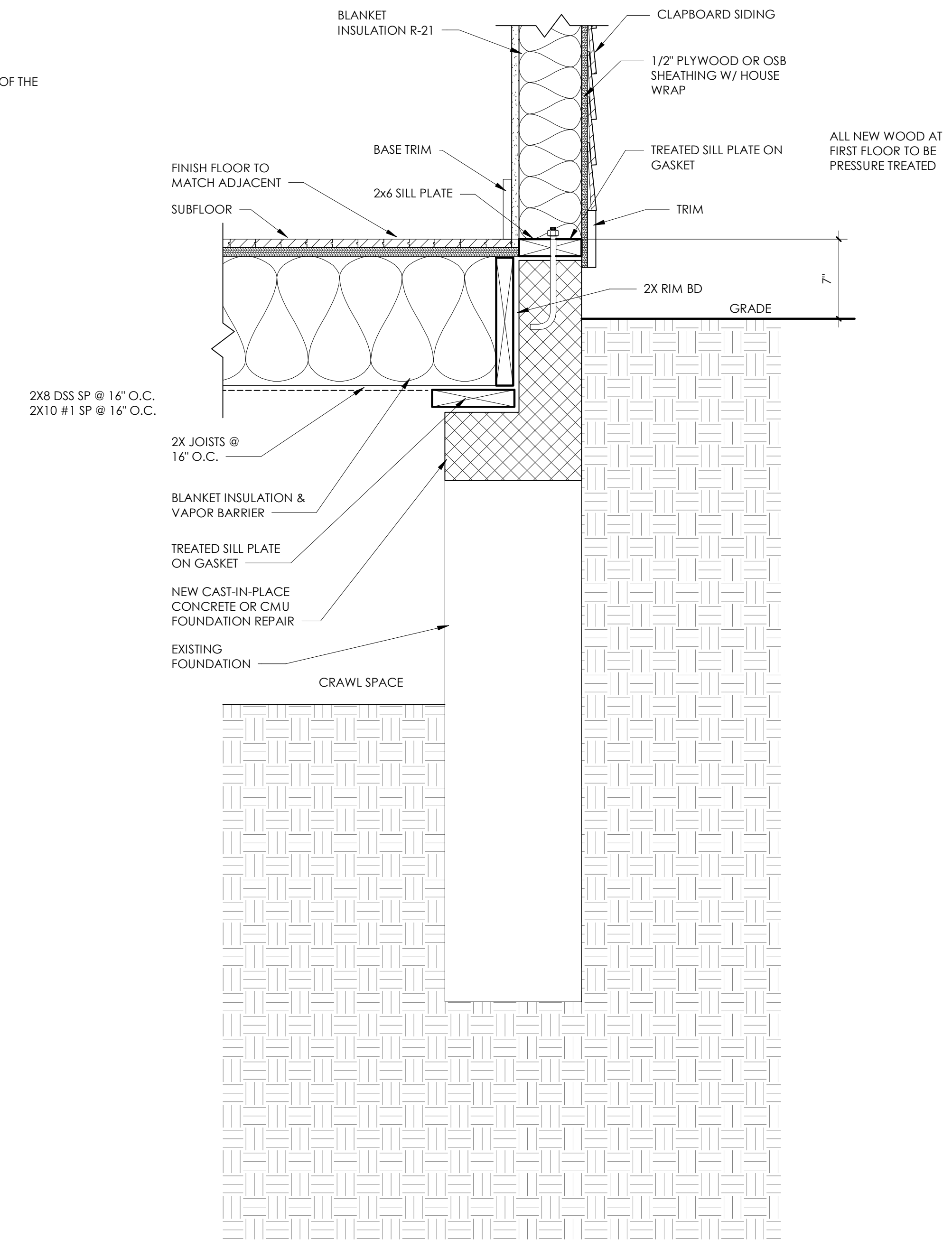
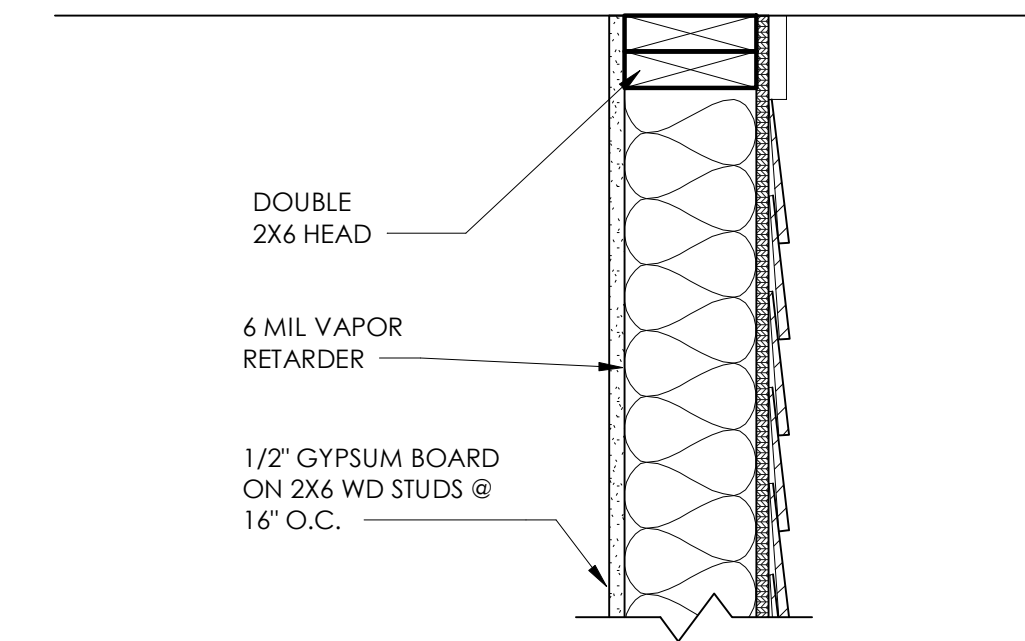

**NEW 2X6 EXTERIOR WALL DETAIL - DRAFT**  
1 1/2" = 1'-0"



**NOT FOR CONSTRUCTION**

CONSULTANT

ISSUED		
#	DATE	DESCRIPTION
A	11-18-19	HDC PREVIEW
B	12-11-19	OWNER REVIEW
C	12-18-19	HDC APPLICATION

**Martinez Residence**  
1137 Traver Rd., Ann Arbor, 48105

General Information





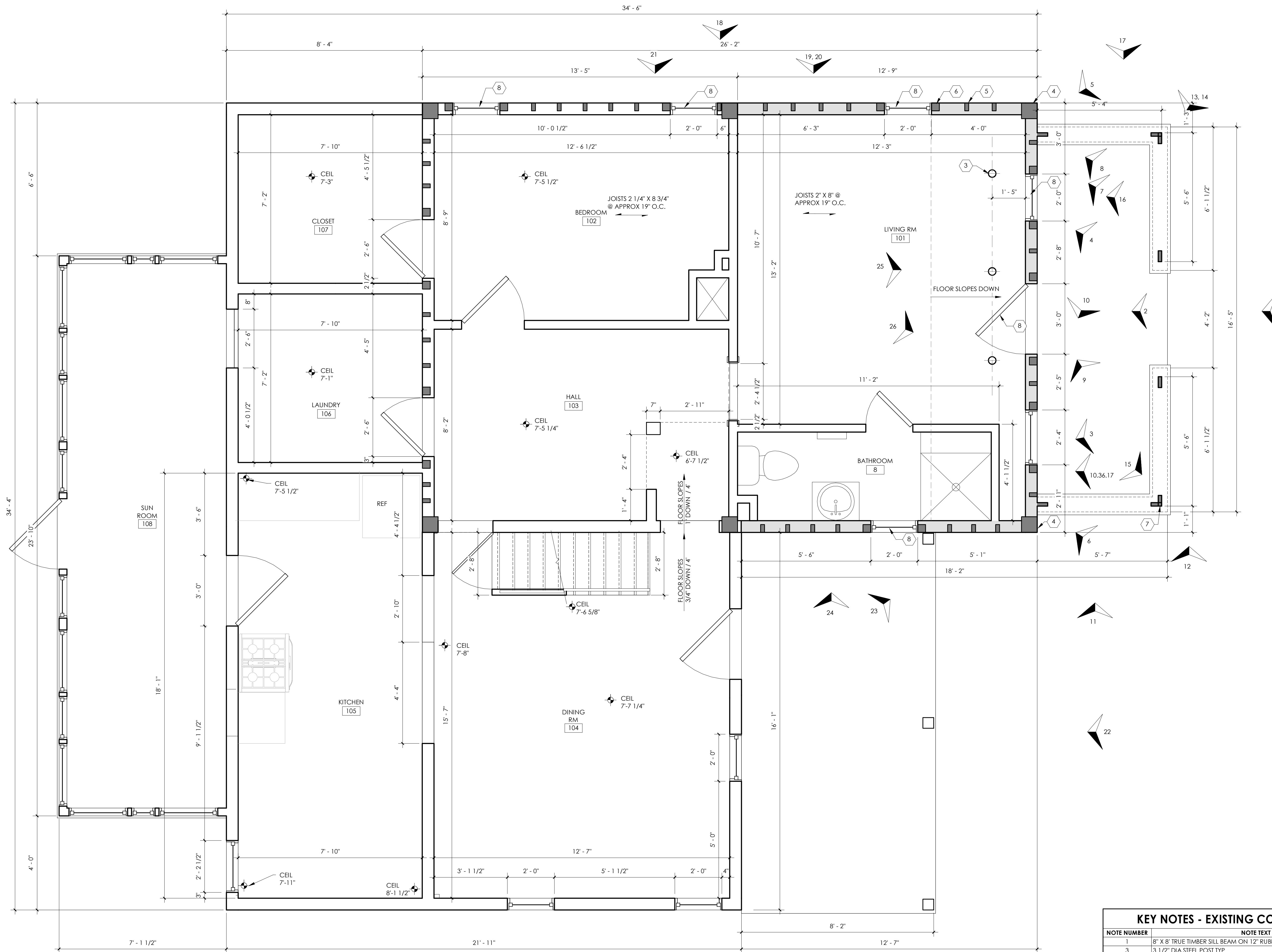

**LEGEND**

- AREA OF WORK
- HISTORICAL POST & BEAM FRAMING
- EXISTING
- DEMOLITION
- NEW CONSTRUCTION



**NOT FOR CONSTRUCTION**

CONSULTANT

ISSUED		
#	DATE	DESCRIPTION
A	10-24-19	REVIEW
B	11-18-19	HDC PREVIEW
C	12-11-19	OWNER REVIEW
D	12-18-19	HDC APPLICATION

**Martinez Residence**  
1137 Traver Rd., Ann Arbor, 48105

Existing First Floor Plan

KEY NOTES - EXISTING CONDITIONS	
NOTE NUMBER	NOTE TEXT
1	8" X 8" TRUE TIMBER SILL BEAM ON 12" RUBBLE FOUNDATION WALL TYP
3	3 1/2" DIA STEEL POST TYP
4	EXISTING 8"X8" TRUE TIMBER COLUMN TYP
5	EXISTING 2"X4" TRUE POST TYP
6	EXIST 4"X4" TRUE POST TYP
7	EXISTING PORCH POST TYP
8	EXISTING WINDOWS AND DOORS ARE NOT HISTORIC TYP

**EXISTING FIRST FLOOR PLAN**  
1/2" = 1'-0"

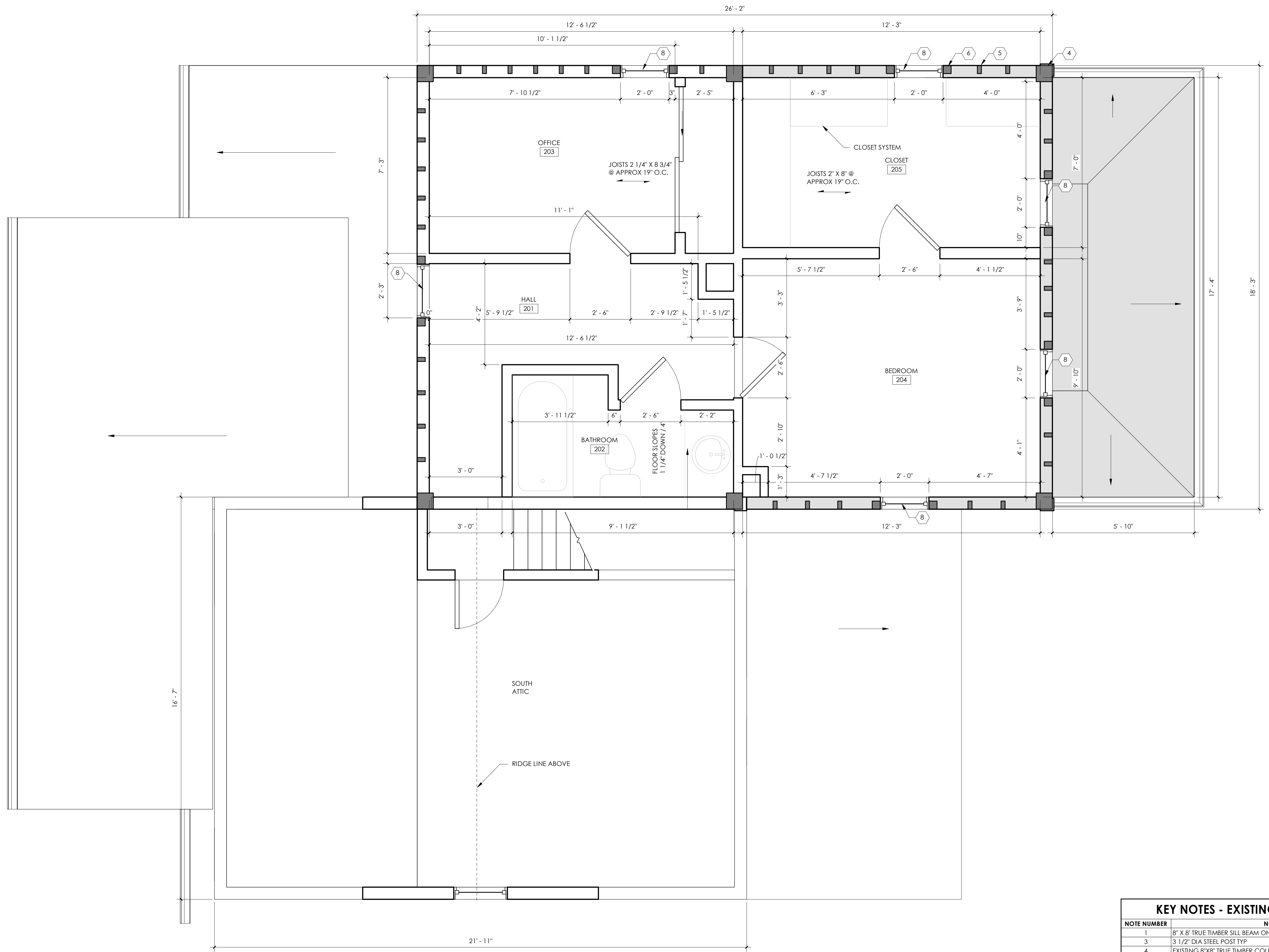

**LEGEND**

- AREA OF WORK
- HISTORICAL POST & BEAM FRAMING
- EXISTING
- DEMOLITION
- NEW CONSTRUCTION

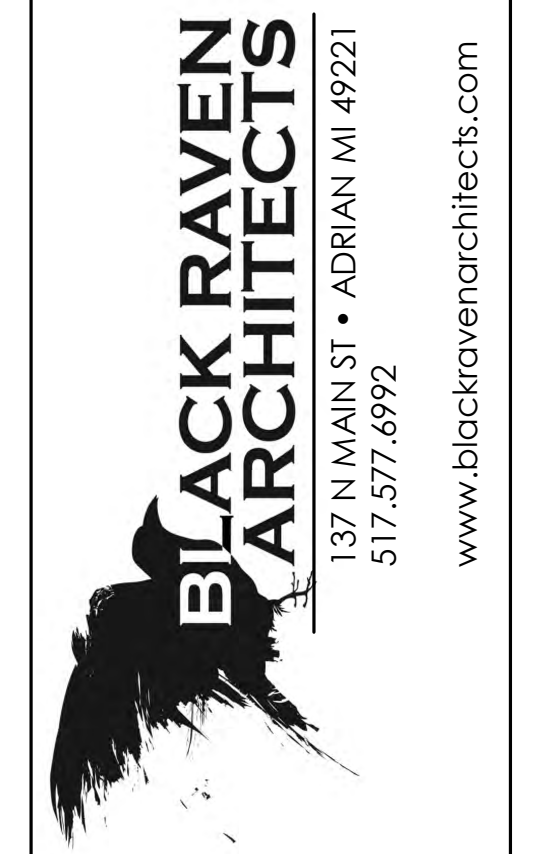

**NOT FOR CONSTRUCTION**

CONSULTANT

**ISSUED**

#	DATE	DESCRIPTION
A	10-24-19	REVIEW
B	11-18-19	HDC PREVIEW
C	12-11-19	OWNER REVIEW
D	12-18-19	HDC APPLICATION

**Marinez Residence**  
 1137 Traver Rd., Ann Arbor, 48105  
 Existing Second Floor Plan

**KEY NOTES - EXISTING CONDITIONS**

NOTE NUMBER	NOTE TEXT
1	8" X 8" TRUE TIMBER SILL BEAM ON 12" RUBBLE FOUNDATION WALL TYP
3	3 1/2" DIA STEEL POST TYP
4	EXISTING 8"X8" TRUE TIMBER COLUMN TYP
5	EXISTING 2"X4" TRUE POST TYP
6	EXIST 4"X4" TRUE POST TYP
7	EXISTING PORCH POST TYP
8	EXISTING WINDOWS AND DOORS ARE NOT HISTORIC TYP

**SECOND FLOOR EXISTING FLOOR PLAN**  
 1/2" = 1'-0"





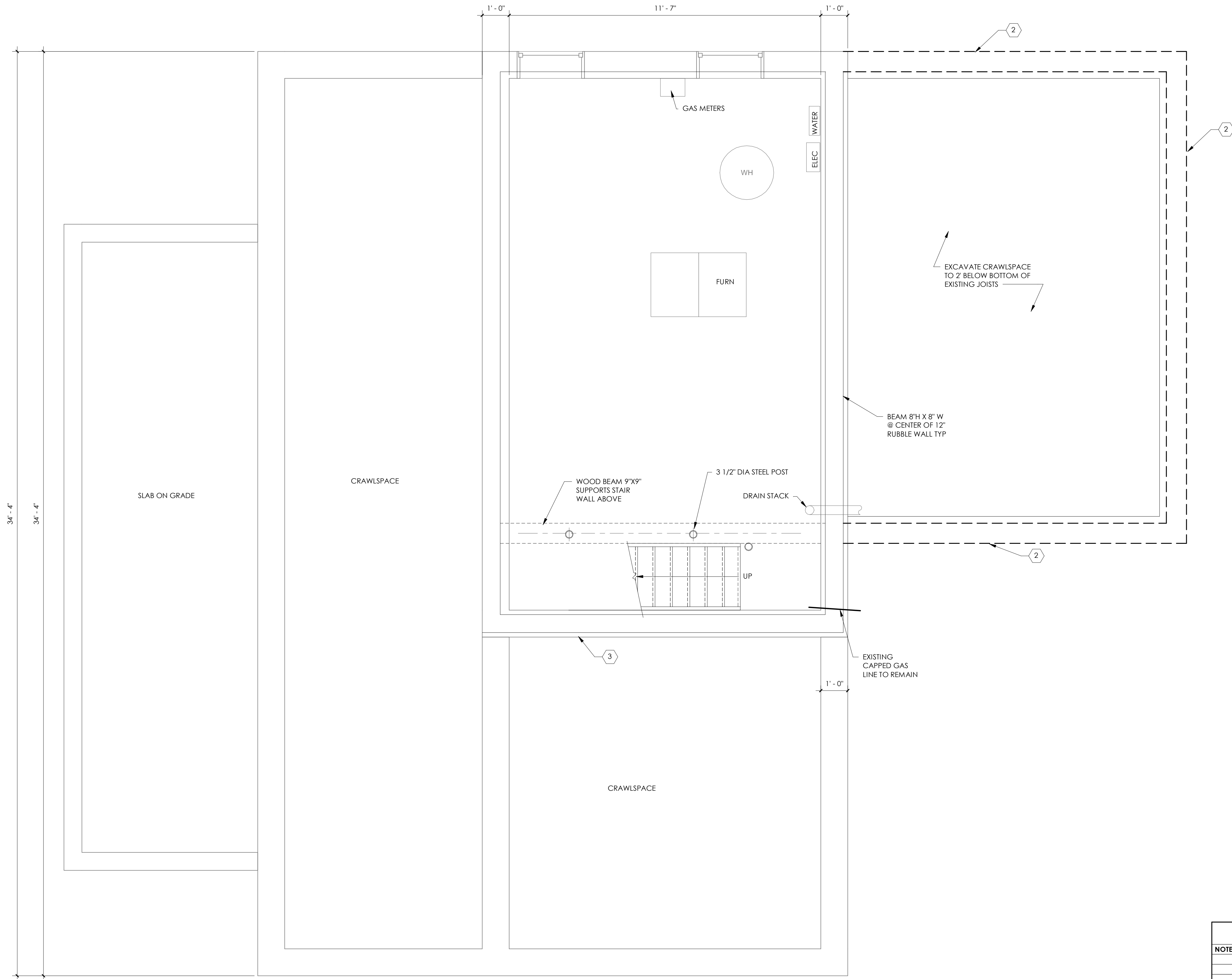

**LEGEND**

- AREA OF WORK
- HISTORICAL POST & BEAM FRAMING
- EXISTING
- - - - - DEMOLITION
- NEW CONSTRUCTION



**NOT FOR CONSTRUCTION**

CONSULTANT

ISSUED		
#	DATE	DESCRIPTION
A	10-24-19	REVIEW
B	11-18-19	HDC PREVIEW
C	12-11-19	OWNER REVIEW
D	12-18-19	HDC APPLICATION

**Martinez Residence**  
 1137 Traver Rd., Ann Arbor, 48105  
 Basement Demolition Plan

NOTE NUMBER	NOTE TEXT
2	REMOVE SILL BEAM AND FOUNDATION DOWN TO SOUND MATERIAL.
3	SILL BEAM AND FOUNDATION TO REMAIN
4	REMOVE WINDOW OR DOOR
5	REMOVE STUCCO AND SIDING TO REVEAL STRUCTURE. REMOVE STRUCTURE WHERE WATER OR INSECT DAMAGE HAS MADE STRUCTURE UNSALVAGABLE. SHORE REMAINING STRUCTURE IN PLACE.
6	REMOVE COLUMN
7	DEMOLISH FLOOR STRUCTURE
8	REMOVE CMU PORCH WALLS, CONCRETE SILL, POSTS, AND ROOF. SALVAGE DECORATIVE TRIM TO USE IN RECREATING PROFILE FOR NEW PORCH CONSTRUCTION.
9	DEMOLISH PORCH SLAB
10	DEMOLISH PORCH SLAB AS NEEDED TO ACCESS SILL BEAM AND WALL FRAMING.
11	DEMOLISH ROOF AND GUTTERS

PROJECT NUMBER:  
 19.41  
 DRAWN BY:  
 BLR  
 ARCHITECT:  
 BLR  
 SHEET NUMBER:  
**AD100**

REAR PORCH FOUNDATION V.I.F.

SLAB ON GRADE

CRAWLSPACE

CRAWLSPACE

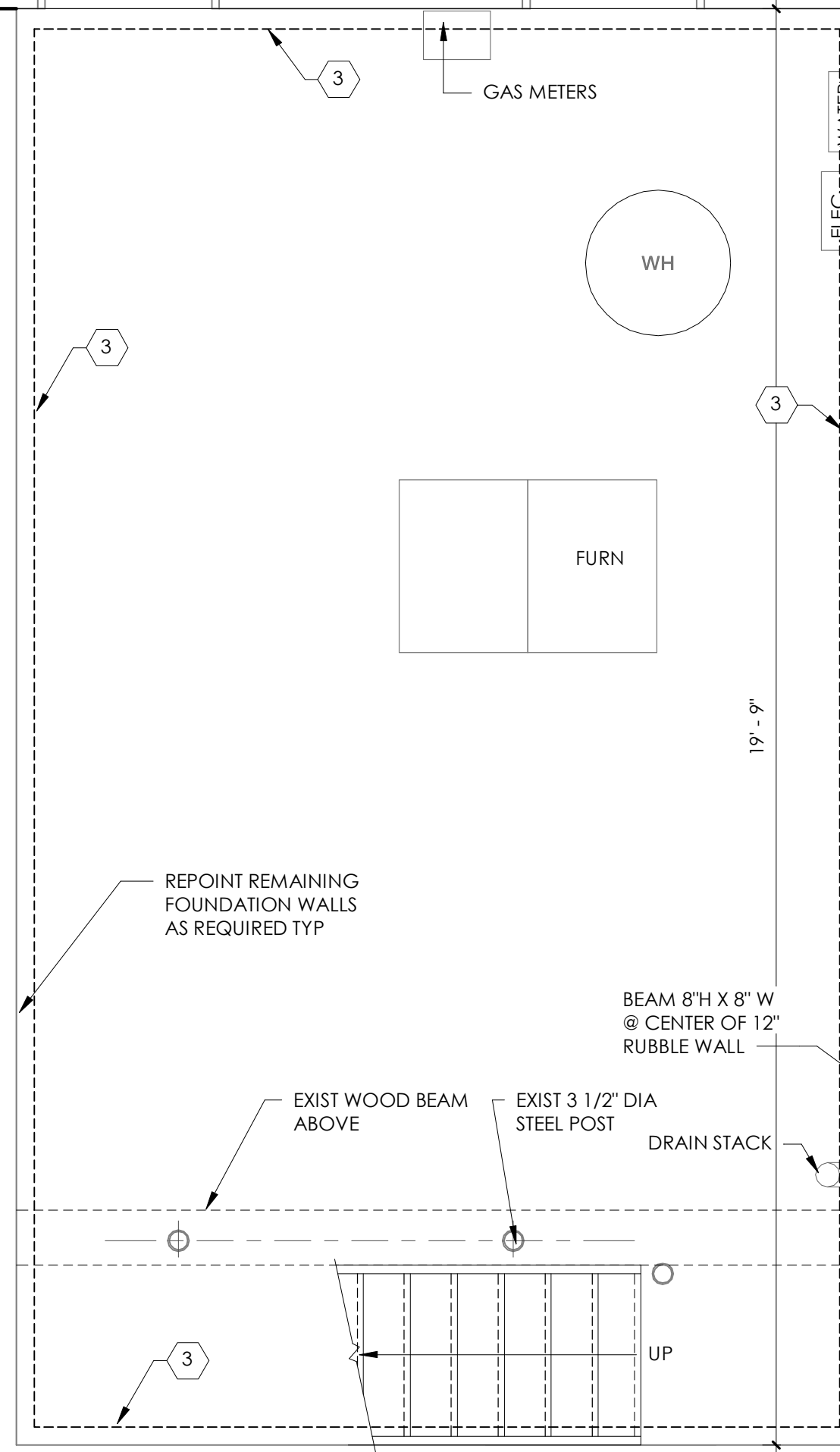

REPOINT REMAINING FOUNDATION WALLS AS REQUIRED TYP

BEAM 8" H X 8" W @ CENTER OF 12" RUBBLE WALL

EXIST WOOD BEAM ABOVE

EXIST 3 1/2" DIA STEEL POST

DRAIN STACK

UP

GAS METERS

WH

FURN

CRAWLSPACE

**LEGEND**

- AREA OF WORK
- HISTORICAL POST & BEAM FRAMING
- EXISTING
- - - - DEMOLITION
- NEW CONSTRUCTION

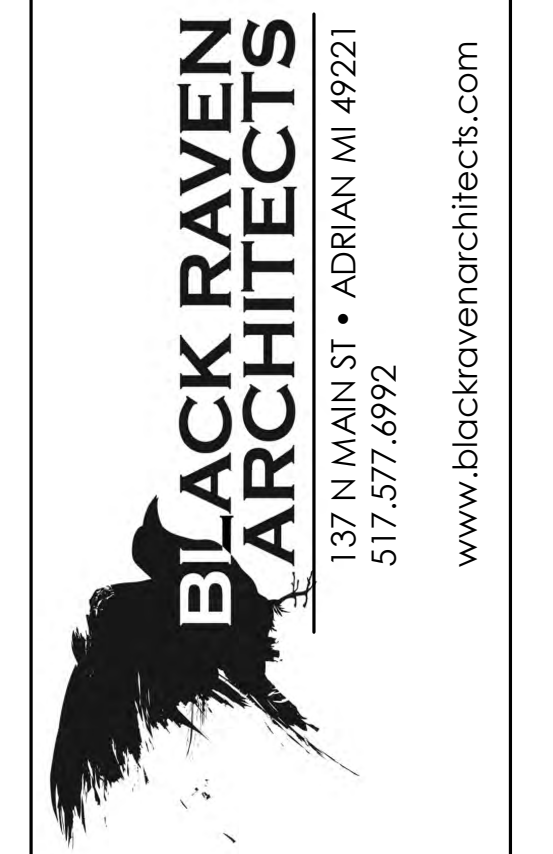

NOT FOR CONSTRUCTION

CONSULTANT

**ISSUED**

#	DATE	DESCRIPTION
A	10-24-19	REVIEW
B	11-18-19	HDC PREVIEW
C	12-11-19	OWNER REVIEW
D	12-18-19	HDC APPLICATION

**KEY NOTES - CONSTRUCTION**

NOTE NUMBER	NOTE TEXT
2	REPAIR TOP OF FOUNDATION
3	REPOINT INTERIOR OF BASEMENT WALLS
4	INSTALL NEW OR SALVAGED WINDOW OR DOOR
5	INSTALL 10 MIL VAPOR RETARDER
6	PORCH POST FOUNDATION
7	NEW 2X6 INSULATED STUD WALL
8	NEW WOOD JOIST FLOOR
9	NEW PORCH SLAB
10	NEW PORCH COLUMN
11	NEW PORCH ROOF AND GUTTERS
12	REPAIR CONCRETE SLAB

**Martinez Residence**  
1137 Traver Rd., Ann Arbor, 48105  
Basement Floor Plan

PROJECT NUMBER: 19.41  
DRAWN BY: BLR  
ARCHITECT: BLR  
SHEET NUMBER: A-100





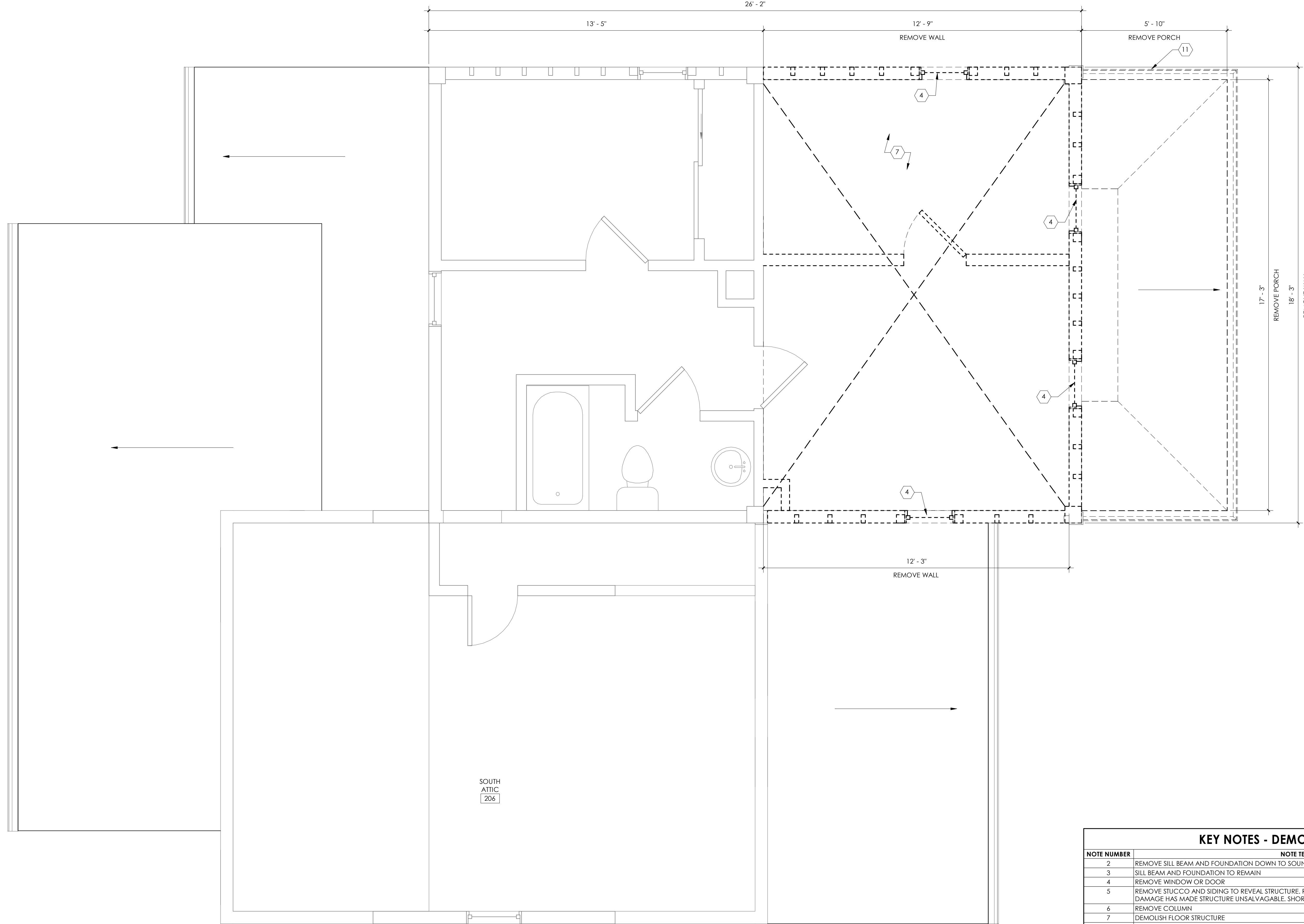

**LEGEND**

- ▭ AREA OF WORK
- ▭ HISTORICAL POST & BEAM FRAMING
- ▭ EXISTING
- ▭ DEMOLITION
- ▭ NEW CONSTRUCTION



**NOT FOR CONSTRUCTION**

CONSULTANT

**ISSUED**

#	DATE	DESCRIPTION
A	10-24-19	REVIEW
B	11-18-19	HDC PREVIEW
C	12-11-19	OWNER REVIEW
D	12-18-19	HDC APPLICATION

**Martinez Residence**  
 1137 Traver Rd., Ann Arbor, 48105  
 Second Floor Demolition Plan

PROJECT NUMBER:  
 19.41  
 DRAWN BY: BLR  
 ARCHITECT: BLR  
 SHEET NUMBER:  
**AD102**

**KEY NOTES - DEMOLITION**

NOTE NUMBER	NOTE TEXT
2	REMOVE SILL BEAM AND FOUNDATION DOWN TO SOUND MATERIAL
3	SILL BEAM AND FOUNDATION TO REMAIN
4	REMOVE WINDOW OR DOOR
5	REMOVE STUCCO AND SIDING TO REVEAL STRUCTURE. REMOVE STRUCTURE WHERE WATER OR INSECT DAMAGE HAS MADE STRUCTURE UNSALVAGABLE. SHORE REMAINING STRUCTURE IN PLACE.
6	REMOVE COLUMN
7	DEMOLISH FLOOR STRUCTURE
8	REMOVE CMU PORCH WALLS, CONCRETE SILL, POSTS, AND ROOF. SALVAGE DECORATIVE TRIM TO USE IN RECREATING PROFILE FOR NEW PORCH CONSTRUCTION.
9	DEMOLISH PORCH SLAB
10	DEMOLISH PORCH SLAB AS NEEDED TO ACCESS SILL BEAM AND WALL FRAMING.
11	DEMOLISH ROOF AND GUTTERS

**SECOND FLOOR DEMOLITION PLAN**  
 1/2" = 1'-0"



**FIRST FLOOR PLAN**  
1/2" = 1'-0"

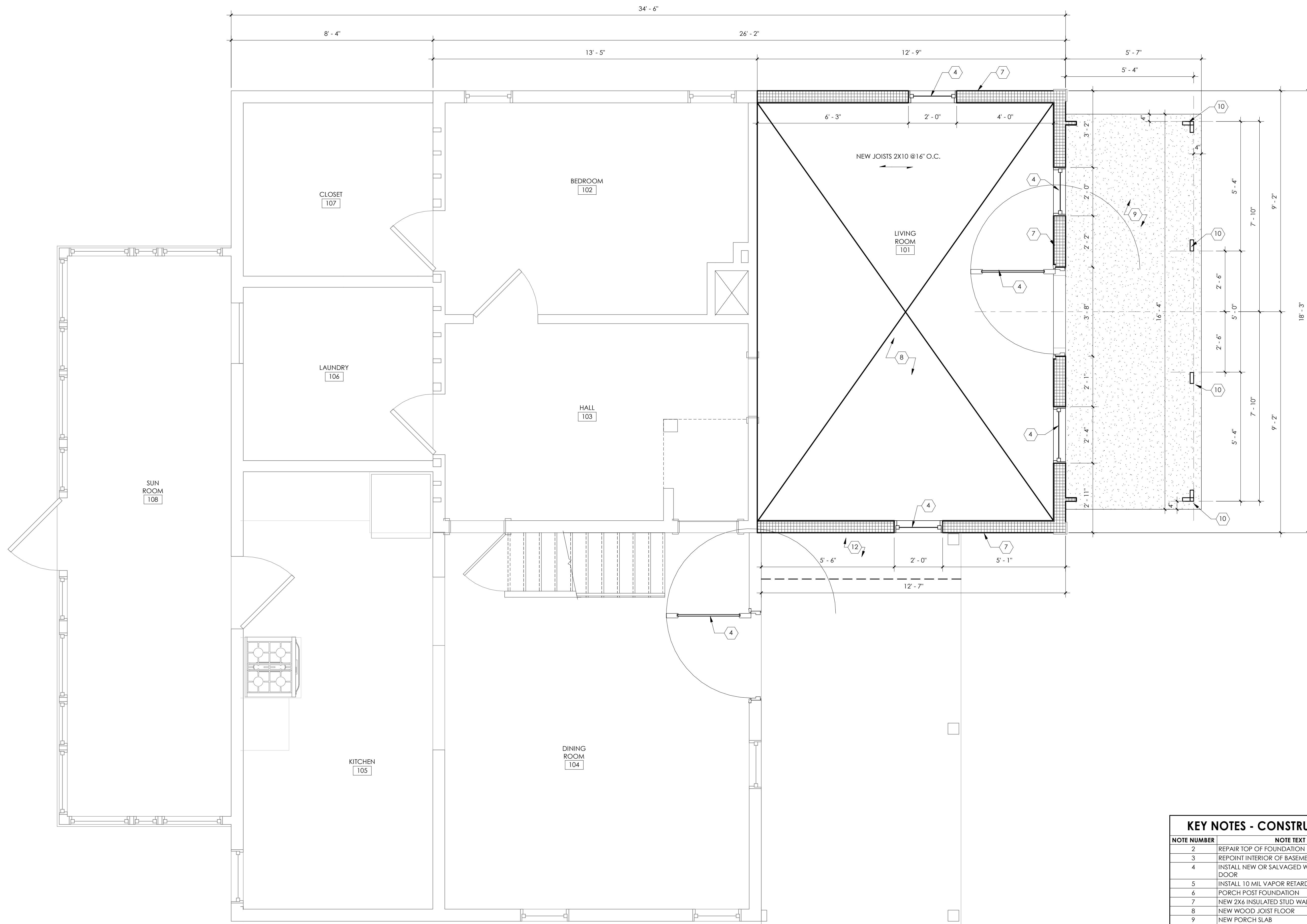

**LEGEND**

- ▬ AREA OF WORK
- ▬ HISTORICAL POST & BEAM FRAMING
- ▬ EXISTING
- ▬ DEMOLITION
- ▬ NEW CONSTRUCTION

**KEY NOTES - CONSTRUCTION**

NOTE NUMBER	NOTE TEXT
2	REPAIR TOP OF FOUNDATION
3	REPOINT INTERIOR OF BASEMENT WALLS
4	INSTALL NEW OR SALVAGED WINDOW OR DOOR
5	INSTALL 10 MIL VAPOR RETARDER
6	PORCH POST FOUNDATION
7	NEW 2X6 INSULATED STUD WALL
8	NEW WOOD JOIST FLOOR
9	NEW PORCH SLAB
10	NEW PORCH COLUMN
11	NEW PORCH ROOF AND GUTTERS
12	REPAIR CONCRETE SLAB



SEALED BY:  
**NOT FOR CONSTRUCTION**

CONSULTANT:

**ISSUED**

#	DATE	DESCRIPTION
A	10-24-19	REVIEW
B	11-18-19	HDC PREVIEW
C	12-11-19	OWNER REVIEW
D	12-18-19	HDC APPLICATION

**Martinez Residence**  
1137 Traver Rd., Ann Arbor, 48105

**First Floor Plan**

PROJECT NUMBER:  
**19.41**

DRAWN BY:  
ACC

ARCHITECT:  
BLR

SHEET NUMBER:  
**A-101**

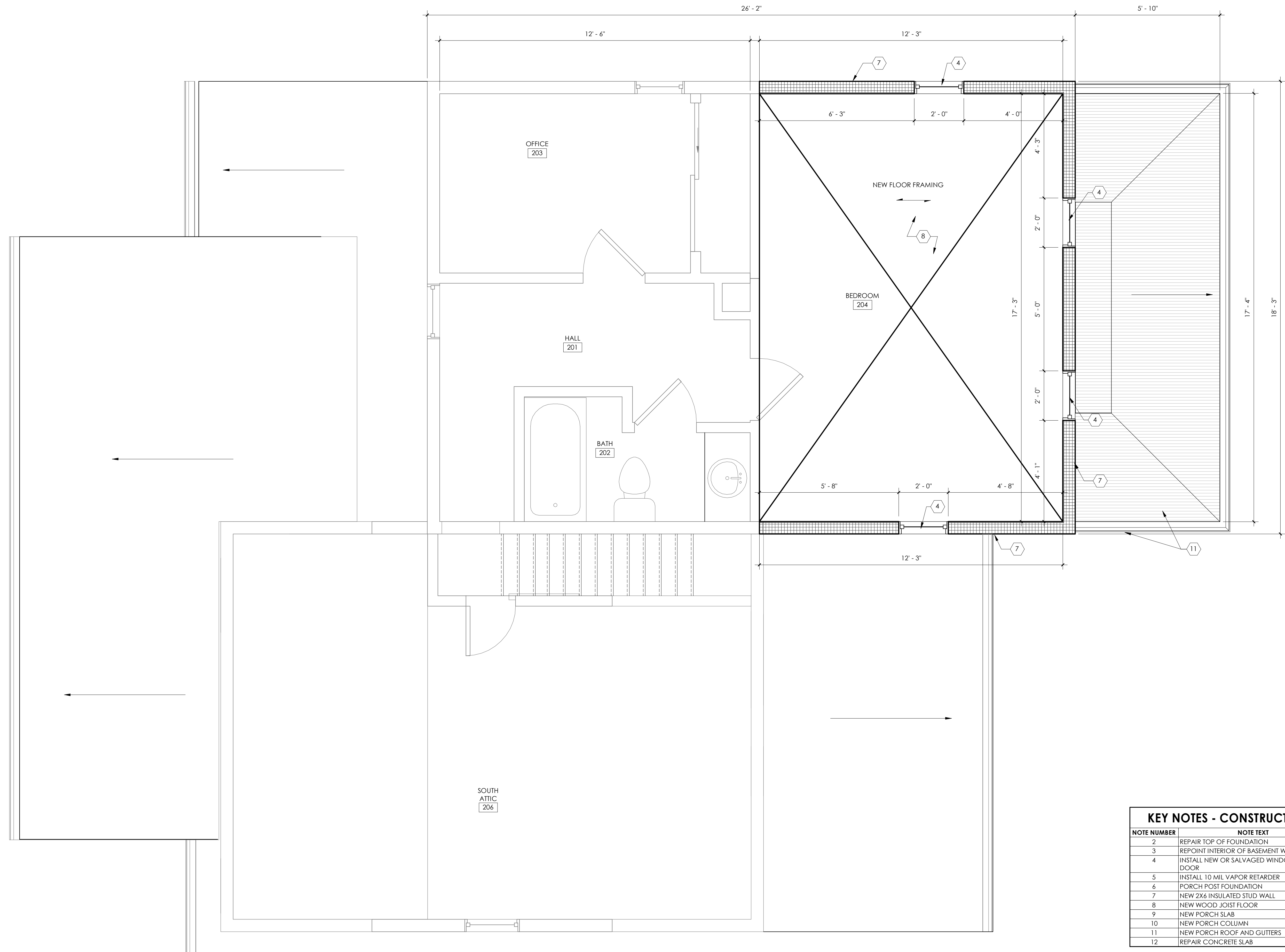

**LEGEND**

- ▨ AREA OF WORK
- ▨ HISTORICAL POST & BEAM FRAMING
- ▨ EXISTING
- ▨ DEMOLITION
- ▨ NEW CONSTRUCTION

**KEY NOTES - CONSTRUCTION**

NOTE NUMBER	NOTE TEXT
2	REPAIR TOP OF FOUNDATION
3	REPOINT INTERIOR OF BASEMENT WALLS
4	INSTALL NEW OR SALVAGED WINDOW OR DOOR
5	INSTALL 10 MIL VAPOR RETARDER
6	PORCH POST FOUNDATION
7	NEW 2X6 INSULATED STUD WALL
8	NEW WOOD JOIST FLOOR
9	NEW PORCH SLAB
10	NEW PORCH COLUMN
11	NEW PORCH ROOF AND GUTTERS
12	REPAIR CONCRETE SLAB

**SECOND FLOOR PLAN**  
1/2" = 1'-0"



**NOT FOR CONSTRUCTION**

SEAL BY: \_\_\_\_\_  
CONSULTANT \_\_\_\_\_

**ISSUED**

#	DATE	DESCRIPTION
A	10-24-19	REVIEW
B	11-18-19	HDC PREVIEW
C	12-11-19	OWNER REVIEW
D	12-18-19	HDC APPLICATION

**Martinez Residence**  
1137 Traver Rd., Ann Arbor, 48105

Second Floor Plan



VERIFY ALL DIMENSIONS AND EXISTING CONDITIONS IN THE FIELD PRIOR TO CONSTRUCTION. DO NOT SCALE FROM DRAWINGS.

© 2019 BLACK RAVEN ARCHITECTS LLC. THIS DOCUMENT AND ALL INFORMATION CONTAINED HEREIN IS THE EXCLUSIVE PROPERTY OF BLACK RAVEN ARCHITECTS AND IS NOT TO BE COPIED OR USED IN ANY WAY WITHOUT THE EXPRESS WRITTEN CONSENT OF BLACK RAVEN ARCHITECTS.

12/19/2019 9:05:46 AM



**EAST ELEVATION**  
1/4" = 1'-0"

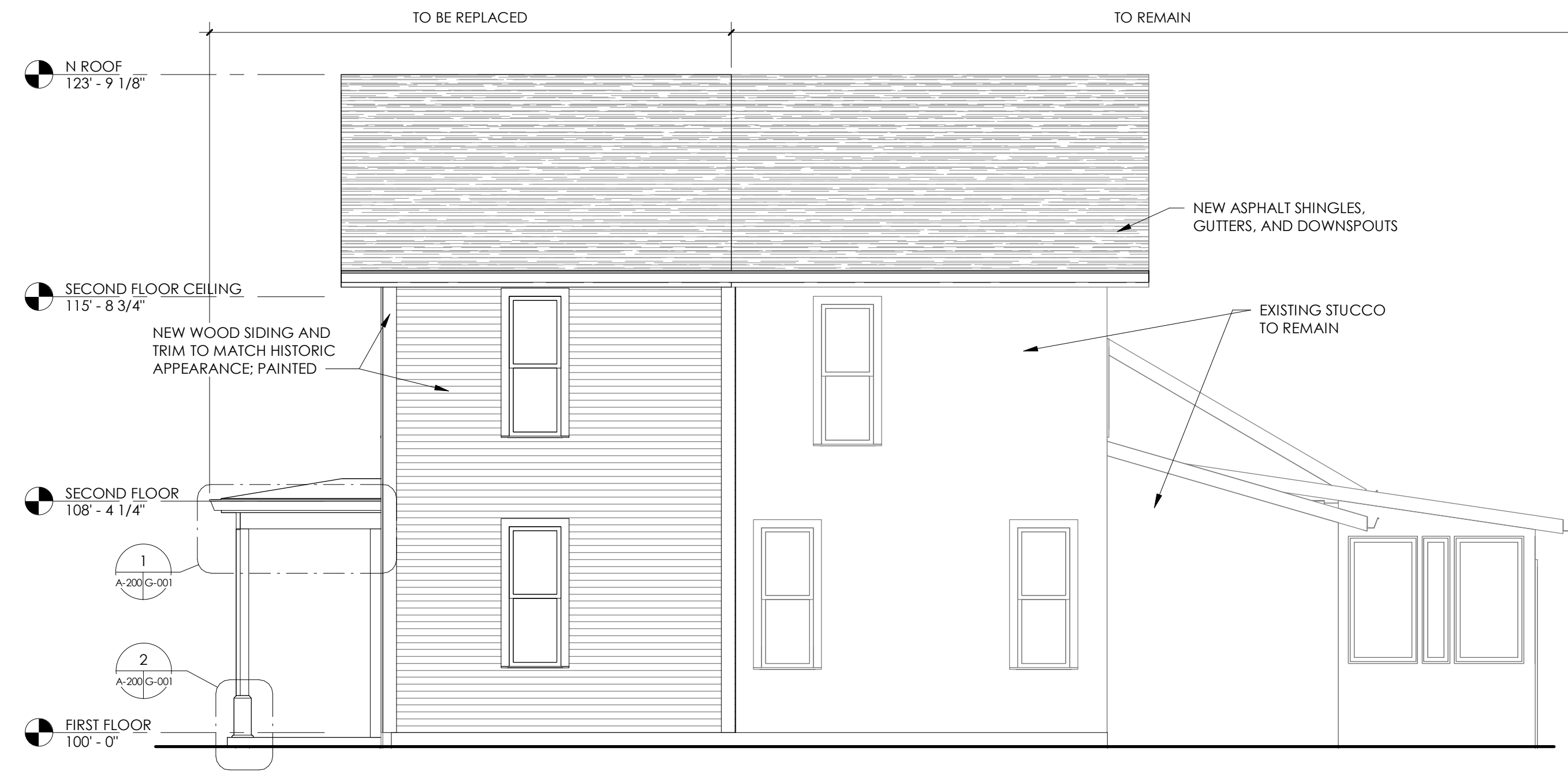

**NORTH ELEVATION**  
1/4" = 1'-0"

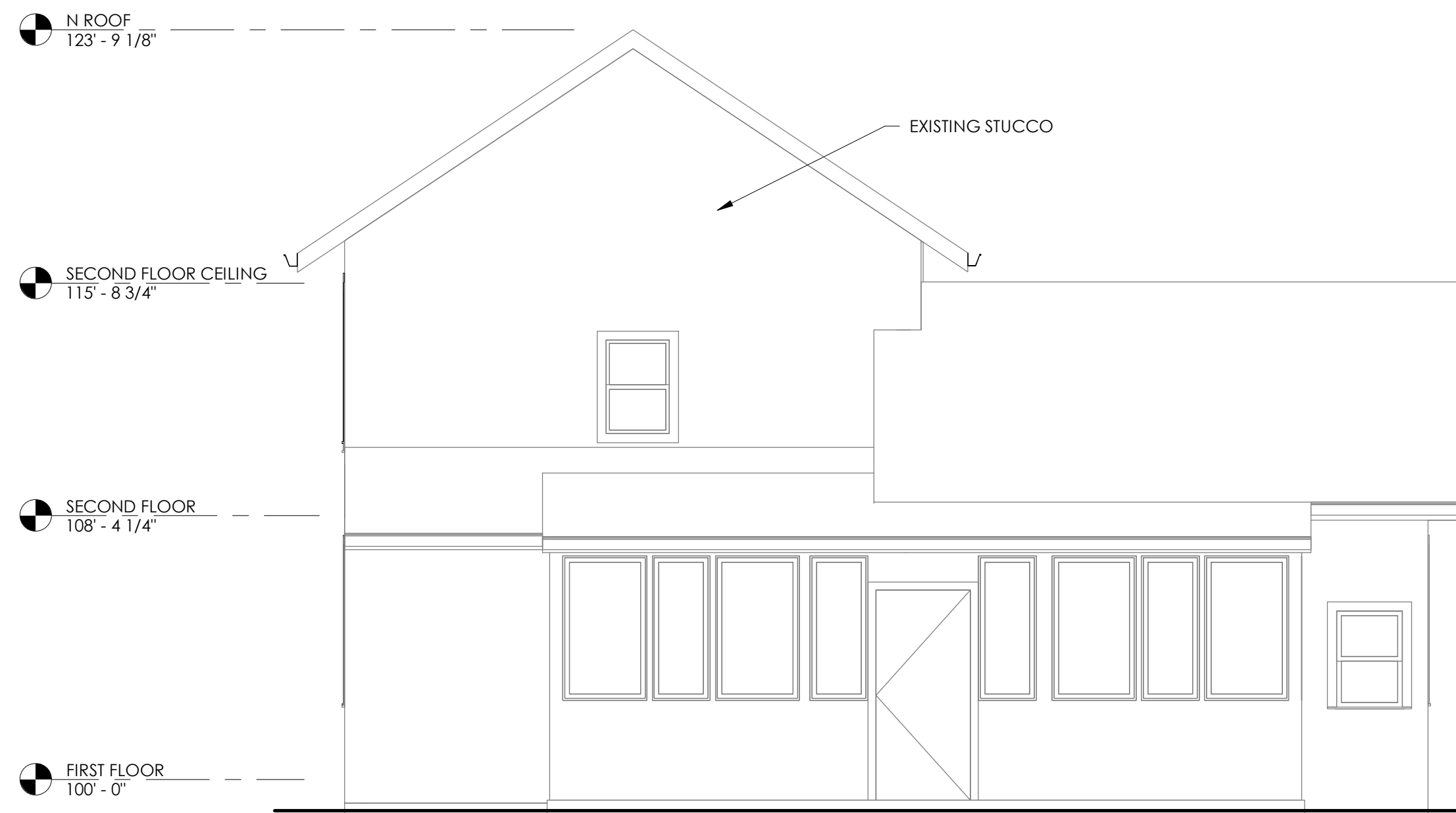

**WEST ELEVATION**  
1/4" = 1'-0" (NO WORK)

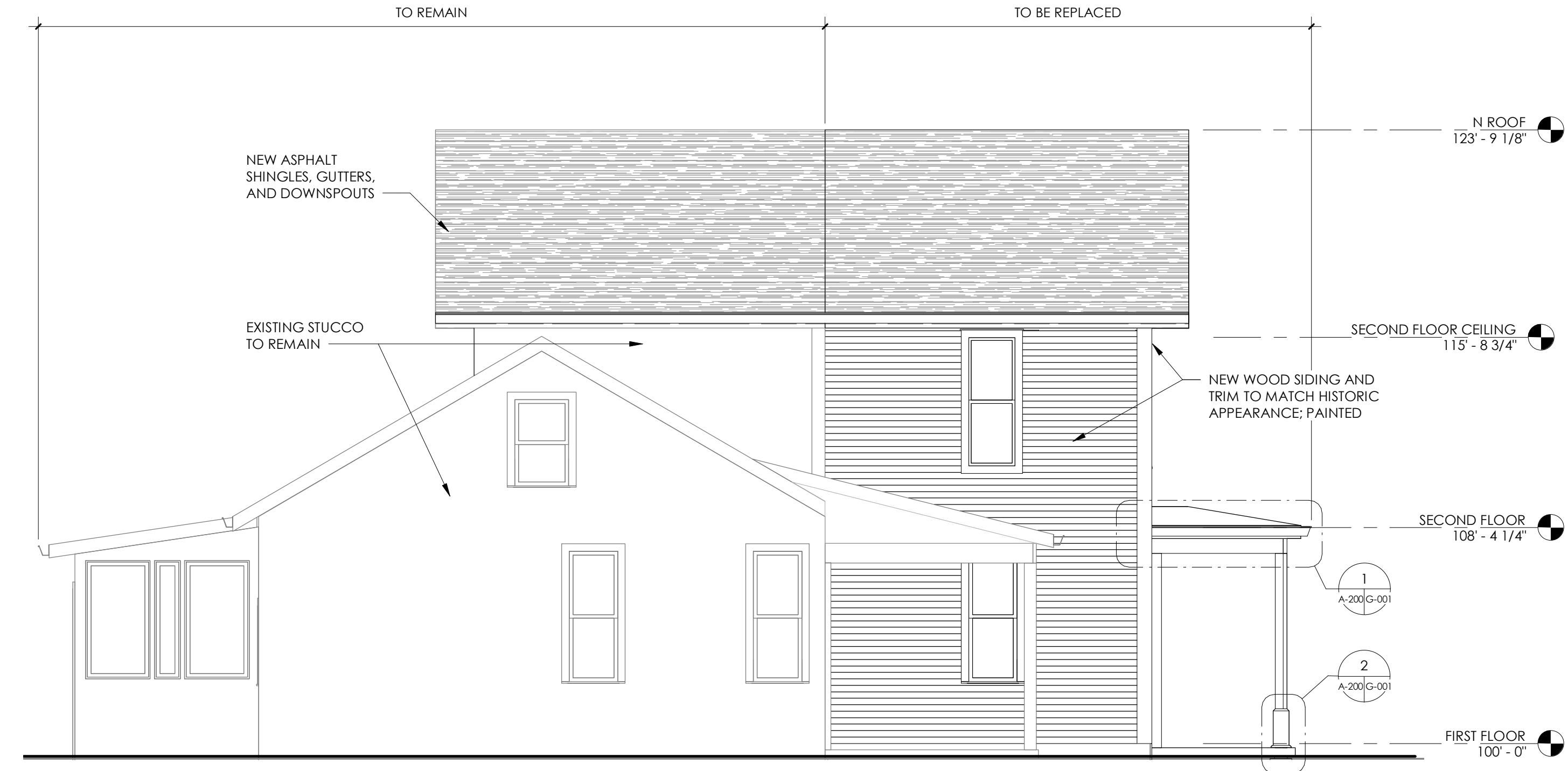

**SOUTH ELEVATION**  
1/4" = 1'-0"



137 N MAIN ST • ADRIAN MI 49221  
517.577.6992  
www.blackravenarchitects.com

SEALED BY:

**NOT FOR CONSTRUCTION**

CONSULTANT

**ISSUED**

#	DATE	DESCRIPTION
A	10-24-19	REVIEW
B	11-18-19	HDC PREVIEW
C	12-11-19	OWNER REVIEW
D	12-18-19	HDC APPLICATION

**Martinez Residence**  
1137 Traver Rd., Ann Arbor, 48105

Elevations

PROJECT NUMBER:  
19.41

DRAWN BY: BLR  
ARCHITECT: BLR  
SHEET NUMBER:  
**A-200**