



FIBER OPTIC CABLE ROUTE
PROJECT # XXXXXXXX (24-04-0046)
PRE-CONSTRUCTION DRAWINGS
LUMEN M14 BIKE TRAIL
ANN ARBOR, MI

APRIL 8, 2024

GENERAL NOTES

- Maintenance of Traffic: Local Traffic must be maintained at all times. The contractor will provide the necessary barricades and lights to protect traffic according to the current standards and specification of the City of Romulus, Wayne County, and the Michigan Manual of Uniform Traffic Control Devices (MMUTCD)
- Contractor must have a copy of the approved permit from the appropriate agency on the jobsite at all times.
- Disturbed areas shall be limited within the right-of-way or easements. Disturbed or damaged landscaping and plantings will be replaced in kind by the contractor, other areas disturbed must be restored to original or better condition.
- Project site will be properly secured prior to the end of each day.
- All work is to be in accordance with all authorities having jurisdiction in the work zone.
- Before construction begins, contractor shall take appropriate precautions to avoid any potential obstructions prior to proceeding with work.
- Safety precautions shall be followed at all times to prevent accidents to vehicular and pedestrian traffic. Signs, barricades, shall be maintained by the contractor.
- The location of all public utilities shown on the plans were taken from the best available records. Underground Contractors, Inc. will not be responsible for any omissions or variations from the locations shown. Before starting construction the contractor shall check with the utility companies on the location of existing utilities and/or structures whether or not indicated on the plans.
- All trenches under or within 3' (three feet) of existing or proposed pavement shall be backfilled with MDOT class II granular material in 8" layers compacted to 95% of maximum unit weight.
- Excavations are to be shored per MIOSHA-STD-1306 PART 9 Excavations, Trenching, & Shoring.
- Hard surface removal necessary on this project to be saw cut full depth and replaced in kind per City of Romulus or Wayne County or MDOT specifications.
- Sidewalk removal required of this project will be accomplished in complete flags and replaced in kind per City of Romulus or Wayne County or MDOT specifications.
- As-Builts will be required for each project including cable footage sequentials at every access point, slack loop, splice location, pole and termination point. Contractor should also provide notes of all changes in depths, running lines, mh/hh locations, and any other applicable notes to depict the work that took place. NOTE: All major changes need to be pre-approved by an authorized Level 3 employee prior to starting the work.
- All conduit will have a minimum of 18" vertical clearance from existing utilities.
- This Project shall be constructed in compliance with Part 91 of Act 451 of 1994 as amended, the soil erosion and sedimentation control act.
- Erosion and any sedimentation from work on this site shall be contained on the site and not allowed to collect on any off site areas or in waterways. Waterways include both natural and man-made open ditches, streams, storm drains, lakes and ponds.
- All work shall be installed in accordance with the Michigan building Code and NFPA 70. Additionally conformances with EIA/TIA and ANSI/NECA/BCSI 568-2001 standards are recommended.
- Fiber not installed in conduit must be plenum material.
- Fiber and conduit shall be labeled with a unique identification at the termination ends and at 50ft intervals along the run.

GENERAL NOTES:

- Contractor must obtain locates prior to disturbing the ground.
- Contractor must have a copy of the approved permit from the appropriate agency on the jobsite at all times.
- Any landscaping will be replaced to equal or better than that which existed prior to work
- Project site will be properly secured prior to the end of each day.
- All work is to be in accordance with all authorities having jurisdiction in the work zone.
- Contractors are advised to contact Level 3 for any additional information or clarification concerning scope of work or the requirements necessary for project completion.
- Contractor is responsible to field verify all dimensions, quantities and existing conditions prior to construction. If a significant change to the running line is needed, please contact your Level 3 representative before proceeding.
- Before construction begins, contractor shall take appropriate precautions to avoid any potential obstructions prior to proceeding with work.
- No construction on private property will commence until approval is given by the appropriate Level 3 employee.
- Contractor shall not proceed with work until they have received a Purchase Order and have been directed to do so by an authorized Level 3 representative.
- Contractor shall not exceed the Purchase Order value without authorization in writing from the appropriate Level 3 representative.
- As-builts will be required for each project including cable footage sequentials at every access point, slack loop, splice location, pole and terminations point. Contractor should also provide notes of all changes in depths, running lines, MH/HH locations, and any other applicable notes to depict the work that took place. NOTE: All major changes need to be pre-approved by an authorized Level 3 employee prior to starting the work.

SITE CONDITIONS:

The actual location of existing conduit and cables may vary from the location shown. Repair of any damaged conduit containing cable shall be made by use of PVC split duct. The contractor shall enclose the existing cables in PVC.

The locations of existing utilities shown in the plan are approximate. When work is to be conducted in the vicinity of known utilities, their actual location must be field verified to avoid conflicts and damage to these utilities. Variation in locations between "recorded positions" and actual positions should be anticipated.

It shall be the contractor's responsibility to verify the location of all underground utilities. Buried utilities may exist in the area in addition to those shown on the plan. The contractor shall contact property owners when working within private easements for location of underground tanks, pipelines, drain tiles, or other buried improvements. The contractor shall also notify the utility notification center prior to commencing any construction activities.

The contractor must assume all buried utilities encountered are alive and active unless specifically instructed otherwise by the owners or operators of said utilities.

Damage to sub-surface structures is the sole responsibility of the placing contractor.

The contractor shall protect the existing traffic control loops. If existing traffic control loops are damaged during construction, the entire loopwire from terminal shall be replaced in accordance with governing agency standards and regulations at contractor's expense.

Removal of existing asphalt pavement, concrete curbs, and concrete sidewalks will be "neat line" with saw or pavement cutter, per requirements and specifications of the agency or department responsible for each location. If concrete pavement is encountered while excavation conduit trenches, the concrete removal will be "neat line" with a pavement saw.

If concrete curb returns and/or sidewalks are replaced due to conduit or manhole installation, the contractor shall place approved handicapped sidewalk and curb access ramps in conformance with State statutes.

All materials necessary for repair of streets, curbs, sidewalks, sanitary sewers, storm sewers, and public service utilities and the installation of such materials shall be in conformance with the requirements and specifications of the agency or department responsible for the operation and maintenance of the repaired facility.

All work shall conform to the specifications of the jurisdictional permit agency.

All open trenches will be clearly marked with barricades or cones. Steel plates or other types of bridging shall be provided to cover open trenches in the travel portion of the streets. These plates or bridging shall be adequate to support the normal vehicle loads anticipated in this area and shall be in place during all non-working hours.

All surface to be restored to original condition, and backfill to be compacted as specified. Trench excavation in surface which include concrete treated base shall follow local area specifications.

HAZARDOUS MATERIAL

The contractor shall notify the jurisdictional permit agency immediately if any materials are encountered that are considered by the EPA, DEQ, or OSHA as hazardous. If potentially hazardous materials are encountered the contractor shall secure the site and prevent any accidental exposure by the public or the contractor's personal.

The contractor may excavate up to, but shall not disturb known hazardous materials such as asbestos, oils, acid, etc. The removal of all hazardous materials must be done by an approved or certified hazardous materials contractor licensed by the state.

A copy of all correspondence pertinent to the removal of the hazardous materials shall be transmitted to the owner and a copy shall be available at the project office and the job site.

CONSTRUCTION STAKES

In areas where the conduit alignment is not clearly defined by the curb lines, fence lines, or other evidence of the right-of-way, the engineer will provide centerline stake or paint marks where required to make the proposed conduit alignment evident.

Closure identified in the plans shall be located by the contractor. Deviation from plan layout shall be approved by the engineer prior to conduit and/or enclosure installation.

Manhole centers will be field staked by the engineer when requested with offset staked at right angles to the conduit alignment

If additional field staking of location of conduit, manholes, property lines, etc. becomes necessary, the contractor is to notify the inspector or the engineer two days prior to the beginning of the work.

PERMITS-FRANCHISES-EASEMENTS

Physical work shall not be started until the governing agency inspector and the contractor are in possession of and have carefully reviewed and fully understand all conditions and specifications set forth in the required permit, franchises and/or easements.

Placing foreman to have a copy of the permits, easements on site at all times.

Any conflict between work print specifications and specifications set forth under related permits, franchises, and/or easements must be cleared by proper company authority before progressing with work involved.

TRAFFIC CONTROL

Any project involving work along a major arterial road and/or heavy traffic volume should be anticipated.

Uniform traffic flow shall be maintained at all times. Only equipment and materials necessary for immediately scheduled or in progress will be maintained in the work area. All other equipment and material will be "stored or stockpiled" in such a manner as to eliminate hazardous conditions for traffic or pedestrians during non-working or shut down period.

Traffic warning devices and signs shall conform to the manual on uniform traffic devices for streets and highways(US Government Printing Office) and to the state highway division standards specifications for highway construction. High level warning type devices are to be used at times and special warning devices may be stipulated by the jurisdictional permit agency at any time he use will add to the safety and protection of traffic or pedestrian in the construction area.

All conduit trenching in paved areas shall be backfilled with crushed gravel or completely covered at the completion of each working day. Any backfilled trench shall be capped with a minimum layer of asphalt or concrete cold patch at the end of each working day.

The contractor shall mark the conduit trench and define their construction area clearly with barricades, cones, and/or other visible methods that alert the public of the construction activity.

A traffic control plan shall be prepared by the contractor as required and submitted to each permitting agency requesting such plan for review and approval or revision prior to commencing any construction activity for this project. The approved plan shall be submitted to the agency and a copy of the plan shall be kept at the construction site and must be available for review by agency representatives.

SPECIAL UTILITY CLEARANCE

All work conducted adjacent water mains shall conform to the following conditions.

- A. Whenever possible conduit shall maintain a horizontal separation of 3', measured surface (outside edge to outside edge) from parallel water mains.
- B. Whenever possible conduit shall pass under existing water mains and must maintain 12" vertical separation.
- C. The contractor shall be responsible for establishing and maintaining this required vertical separation by either exposing the water main every 100 feet in these areas where horizontal separation is less than 3 feet or by utilizing the depths of adjacent water valves. If the contractor utilizes the adjacent water line to determine water main depth, they shall contact the agency at each such location and the agency will determine the necessary depth of the top of the conduit at that point.
- D. The vertical and horizontal separation shall be maintained at all times unless specifically revised by agreement between the jurisdictional permit agency and the agency. Any specific deviation in the vertical and horizontal separation from those described shall be reported to the owner by the contractor. The contractor shall be responsible for maintaining vertical and horizontal separation at all times and shall be responsible for any and all encroachments.
- E. Clearances to storm sewer and sanitation sewers shall be exactly the same as those to water mains.

STRUCTURE PROTECTION

Manholes and conduit to be placed adjacent to existing structures such as bridges, bridge footing/piers, foundations, walls, power and telephone poles, ad other utilities shall maintain a minimum clearance as shown. The contractor shall not undermine any adjacent structure without specific written permission form the owner/operation of such structure.

Shoring used as foundation support shall be designed specifically for both the live and dead loads off the structure or if only the dead is used for design. The contractor shall provide a detailed layout and plan of the method of establishing and maintaining the design load condition (i.e. road detours, tiebacks, etc.).

See utility clearance section notes for the clearance criteria to parallel or cross utilities.

Existing utilities exposed during excavation shall be 100% supported by either trench bridging and suspension or by the use of longitudinal trays or platforms vertically supported by adjustable building jacks.

Existing splice cases and cable supported by suspension from a cross beam. Supports shall be placed at a maximum spacing of 4 feet and shall consist of a canvas sling with nylon belting or rope. All cable support shall be placed in a manner that prevents kinks or other damage to the cable sheath.

An acceptable alternative to cable slings would be the utilization of a wide flange "I" bean or channel as a "cable tray" with cables/cases banded in place.

SHORING

The contractor shall provide shoring for conduit trench excavation 48" or more in depth as measured from the high side of the trench and for all manhole excavation.

Manhole shoring shall be tight-sheeted.

All shoring shall conform to the standards and specifications of local party and the occupational safety health administration.

The contractor shall provide all shoring and design calculations to the permit issuing agency prior to commencing any construction activity.



PROJECT: # 24-04-0046

SEGMENT: SEG/SPAN

PRE CONSTRUCTION PLANS
TO
LUMEN – ANN ARBOR BIKE PATH



REVISIONS

DATE	DESCRIPTION	INITIAL

EXCEPT AS MAY BE OTHERWISE PROVIDED BY CONTRACT, THESE DRAWINGS AND SPECIFICATIONS SHALL REMAIN THE PROPERTY OF LEVEL3 COMMUNICATIONS. BEING ISSUED IN STRICT CONFIDENCE AND SHALL NOT BE REPRODUCED, COPIED, OR USED FOR ANY PURPOSE WITHOUT SPECIFIC WRITTEN PERMISSION.



Know what's below.
Call before you dig.

LEVEL3 COMMUNICATIONS. IS NOT RESPONSIBLE FOR ANY UTILITY LOCATIONS SHOWN OR NOT SHOWN ON THIS DRAWING

PROPOSED
ORIGINAL: **4/8/2024**

REVISED:
SCALE

B SIZE DWG: 1:40
D SIZE DWG: 1:40

MP TO MP

DWG. # **LOCATION**
2 OF 9



PROJECT: #24-04-0046

SEGMENT: SEG/SPAN

PRE CONSTRUCTION PLANS
TO
LUMEN - ANN ARBOR BIKE PATH



REVISIONS

DATE	DESCRIPTION	INITIAL

EXCEPT AS MAY BE OTHERWISE PROVIDED BY CONTRACT, THESE DRAWINGS AND SPECIFICATIONS SHALL REMAIN THE PROPERTY OF LEVEL3 COMMUNICATIONS. BEING ISSUED IN STRICT CONFIDENCE AND SHALL NOT BE REPRODUCED, COPIED, OR USED FOR ANY PURPOSE WITHOUT SPECIFIC WRITTEN PERMISSION.



Know what's below.
Call before you dig.

LEVEL3 COMMUNICATIONS. IS NOT RESPONSIBLE FOR ANY UTILITY LOCATIONS SHOWN OR NOT SHOWN ON THIS DRAWING

PROPOSED

ORIGINAL: 04/08/2024

REVISED:

SCALE

B SIZE DWG:
D SIZE DWG:

MP TO MP

DWG. # LOCATION
3 OF 9

OUTSIDE PLANT ENGINEERING:

LUMEN TECHNOLOGIES
SR NETWORK IMPLEMENTATION MANAGER
19675 W 10 MILE RD
SOUTHFIELD MI 48075
SCOTT ANTONE
OFFICE: (248) 436-9852
CELL: 517-206-8644
E-MAIL: "SCOTT.ANTONE@LUMEN.COM"

OUTSIDE PLANT CONSTRUCTION:

CENTURYLINK COMMUNICATION CORP, LLC.
SR ENGINEER "AREA OF RESPONSIBILITY"
"ADDRESS"
"CITY, STATE ZIP"
"ENGINEER NAME"
OFFICE: (XXX) XXX-XXXX
FAX: (XXX) XXX-XXXX
CELL: (XXX) XXX-XXXX
E-MAIL: "ENGINEER@CENTURYLINK.COM"

ENGINEERING CONTRACTOR:

UNDERGROUND CONTRACTORS INC.
30561 ANDERSEN CT.
WIXOM, MI 48393
DEBORA RENNER
OFFICE: (248) 669-2510 EXT. 405
FAX: 248-669-1483
CELL: 248-756-4156
E-MAIL: DRENNER@UNDERGROUNDCONTRACTORS.COM

CONSTRUCTION CONTRACTOR:

"COMPANY NAME"
"ADDRESS"
"CITY, STATE ZIP"
"PROJECT ENGINEER NAME"
OFFICE: (XXX) XXX-XXXX
FAX: (XXX) XXX-XXXX
CELL: (XXX) XXX-XXXX
E-MAIL: "ENGINEER@COMPANY.COM"

STATE GOVERNMENT:

"STATE AGENCY"
"CONTACT"
"ADDRESS"
"CITY, STATE ZIP"
"ENGINEER NAME"
OFFICE: (XXX) XXX-XXXX
FAX: (XXX) XXX-XXXX
CELL: (XXX) XXX-XXXX
E-MAIL: "E-MAIL ADDRESS"

COUNTY GOVERNMENT

"COUNTY AGENCY"
"CONTACT"
"ADDRESS"
"CITY, STATE ZIP"
"ENGINEER NAME"
OFFICE: (XXX) XXX-XXXX
FAX: (XXX) XXX-XXXX
CELL: (XXX) XXX-XXXX
E-MAIL: "E-MAIL ADDRESS"

CITY GOVERNMENT:

RAILROAD:

"RAILROAD"
"CONTACT"
"ADDRESS"
"CITY, STATE ZIP"
OFFICE: (XXX) XXX-XXXX
FAX: (XXX) XXX-XXXX
CELL: (XXX) XXX-XXXX
E-MAIL: "E-MAIL ADDRESS"

UTILITIES:

CENTURYLINK ONE-CALL
OFFICE: 1-800-289-4237

OTHER ONE-CALL
OFFICE: (XXX)-XXX-XXXX
DAVE HUCKFELDT 517-812-2592
SCOTT ANTONE 517-206-8644

OTHER:

DRAFTING STANDARD SYMBOLOGY

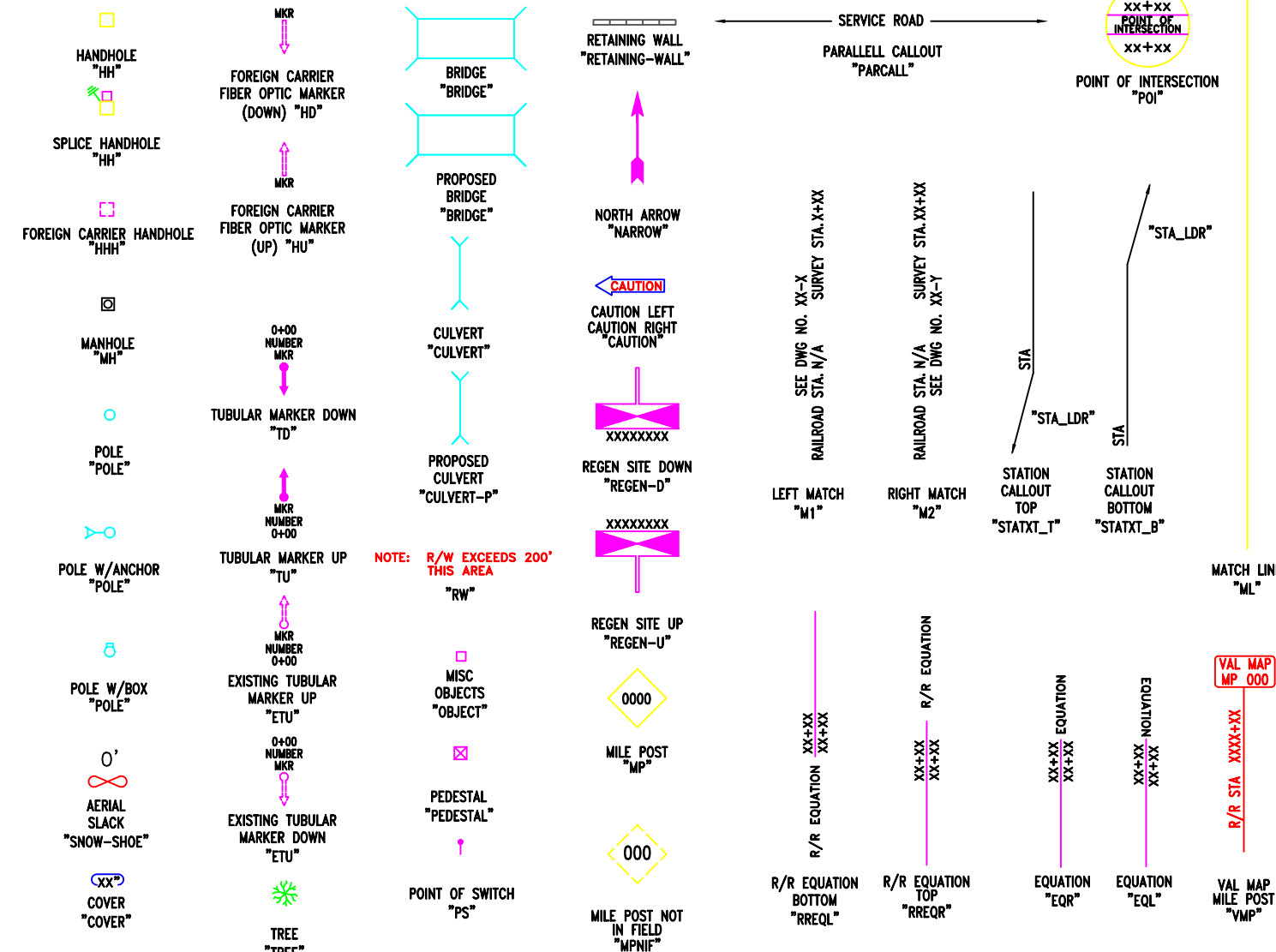

CABLE SYMBOLS

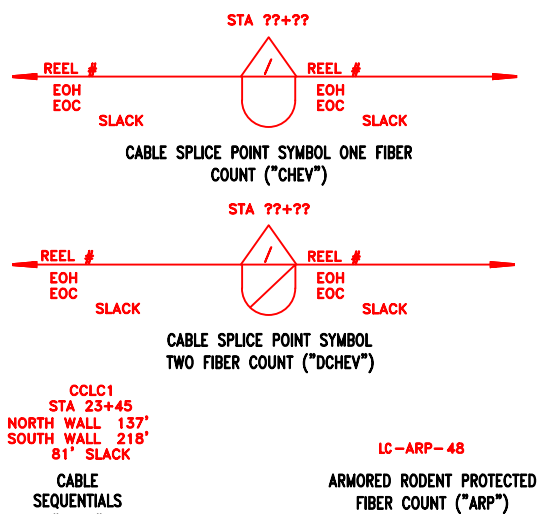

LEVEL3 LINE LEGEND

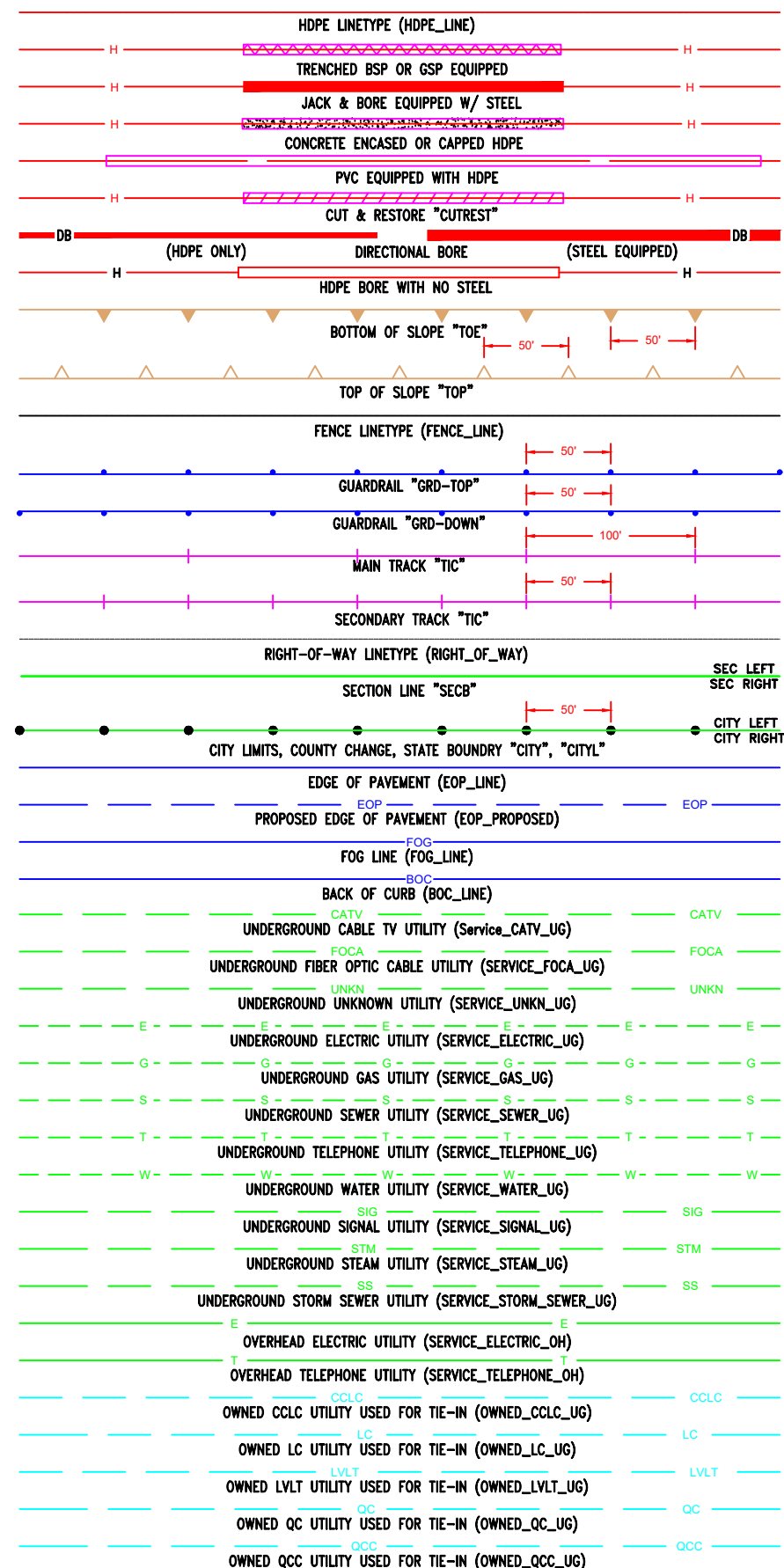

PROJECT: #24-04-0046
SEGMENT: SEG/SPAN
PRE CONSTRUCTION PLANS TO LUMEN - ANN ARBOR BIKE PATH



REVISIONS

DATE	DESCRIPTION	INITIAL

EXCEPT AS MAY BE OTHERWISE PROVIDED BY CONTRACT, THESE DRAWINGS AND SPECIFICATIONS SHALL REMAIN THE PROPERTY OF LEVEL3 COMMUNICATIONS. BEING ISSUED IN STRICT CONFIDENCE AND SHALL NOT BE REPRODUCED, COPIED, OR USED FOR ANY PURPOSE WITHOUT SPECIFIC WRITTEN PERMISSION.



Know what's below. Call before you dig.

LEVEL3 COMMUNICATIONS IS NOT RESPONSIBLE FOR ANY UTILITY LOCATIONS SHOWN OR NOT SHOWN ON THIS DRAWING

PROPOSED ORIGINAL: 04/08/2024

REVISED:

SCALE

B SIZE DWG: 1:40
D SIZE DWG: 1:40

MP TO MP

DWG. # LOCATION
4 OF 9

"BLOCK NAMES IN QUOTES"
(LINETYPES IN PARENTHESES)

Under UCI project manager supervision , score existing conduit (with approved tools) , exposing existing 108ct live fiber leaving fiber intact , pull slack as needed from existing storage location, add split duct as needed and secure per design, in case the fiber is damaged during exposure STOP , do not proceed until appropriate UCI management is notified and that management has given the approval to continue.

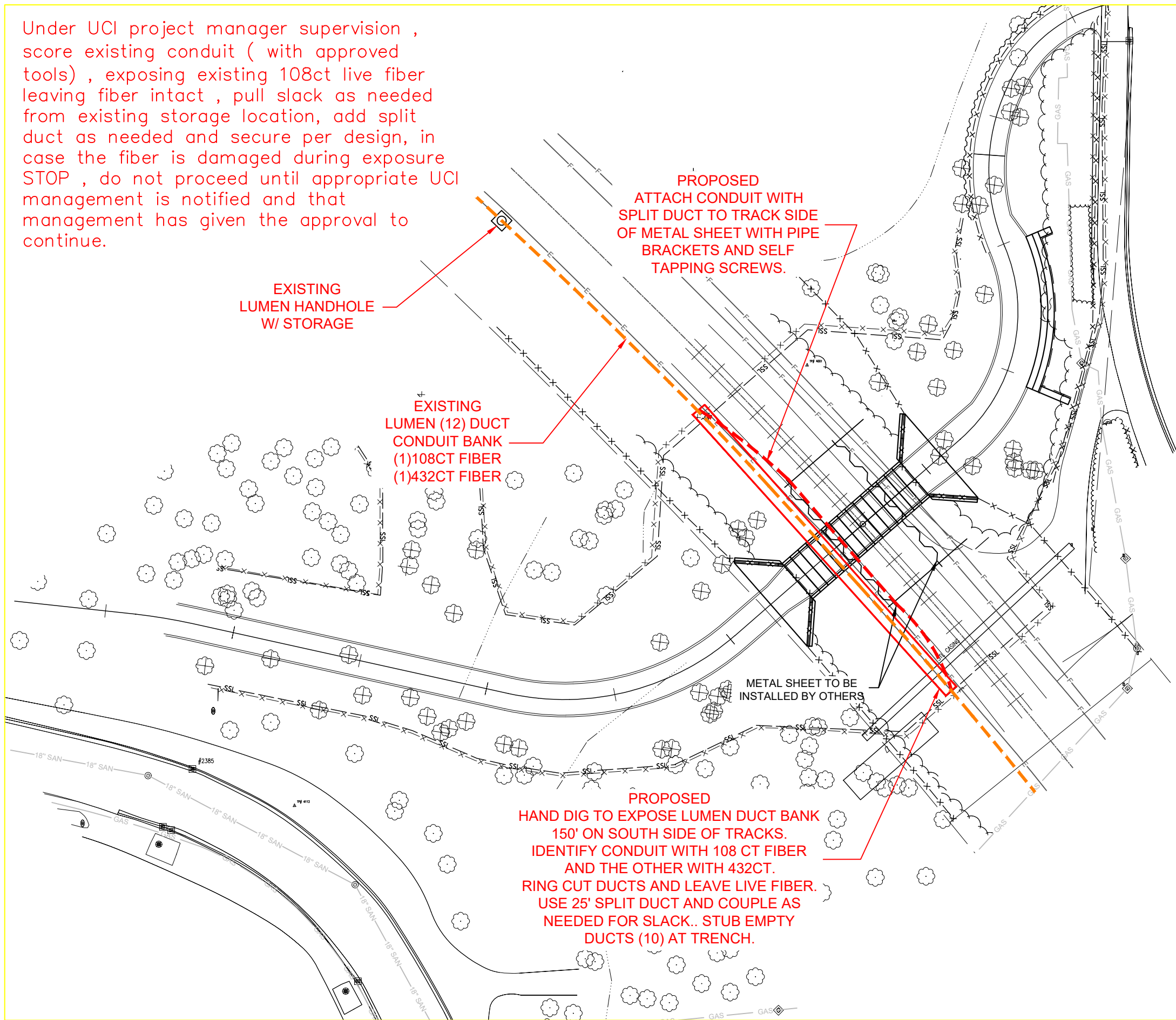

PROJECT: #24-04-0046

SEGMENT: SEG/SPAN

PHASE 1
TO
LUMEN - ANN ARBOR BIKE PATH



REVISIONS

DATE	DESCRIPTION	INITIAL

EXCEPT AS MAY BE OTHERWISE PROVIDED BY CONTRACT, THESE DRAWINGS AND SPECIFICATIONS SHALL REMAIN THE PROPERTY OF LEVEL3 COMMUNICATIONS. BEING ISSUED IN STRICT CONFIDENCE AND SHALL NOT BE REPRODUCED, COPIED, OR USED FOR ANY PURPOSE WITHOUT SPECIFIC WRITTEN PERMISSION.



Know what's below.
Call before you dig.

LEVEL3 COMMUNICATIONS. IS NOT RESPONSIBLE FOR ANY UTILITY LOCATIONS SHOWN OR NOT SHOWN ON THIS DRAWING

PROPOSED
ORIGINAL: 04/08/2024

REVISED:

SCALE
B SIZE DWG: 1:40
D SIZE DWG: 1:40

MP TO MP

DWG. # LOCATION
5 OF 9



PROJECT: # 24-04-0046

SEGMENT: SEG/SPAN

PHASE 1
TO
LUMEN - ANN ARBOR BIKE PATH



REVISIONS

DATE	DESCRIPTION	INITIAL

EXCEPT AS MAY BE OTHERWISE PROVIDED BY CONTRACT, THESE DRAWINGS AND SPECIFICATIONS SHALL REMAIN THE PROPERTY OF LEVEL3 COMMUNICATIONS. BEING ISSUED IN STRICT CONFIDENCE AND SHALL NOT BE REPRODUCED, COPIED, OR USED FOR ANY PURPOSE WITHOUT SPECIFIC WRITTEN PERMISSION.



Know what's below.
Call before you dig.

LEVEL3 COMMUNICATIONS. IS NOT RESPONSIBLE FOR ANY UTILITY LOCATIONS SHOWN OR NOT SHOWN ON THIS DRAWING

PROPOSED
ORIGINAL: 04/08/2024
REVISED:

SCALE
B SIZE DWG: 1:40
D SIZE DWG: 1:40

MP TO MP
DWG. # LOCATION
6 OF 9

PROPOSED
HAND DIG TO EXPOSE LUMEN DUCT BANK 150' ON SOUTH SIDE OF TRACKS.
IDENTIFY CONDUIT WITH 108 CT FIBER AND THE OTHER WITH 432CT.
RING CUT DUCTS AND LEAVE LIVE FIBER. USE 25' SPLIT DUCT AND COUPLE AS NEEDED FOR SLACK.. STUB EMPTY DUCTS (10) AT TRENCH.

EXISTING LUMEN 12 DUCT CONDUIT BANK
(1)108CT FIBER
(1)432CT FIBER

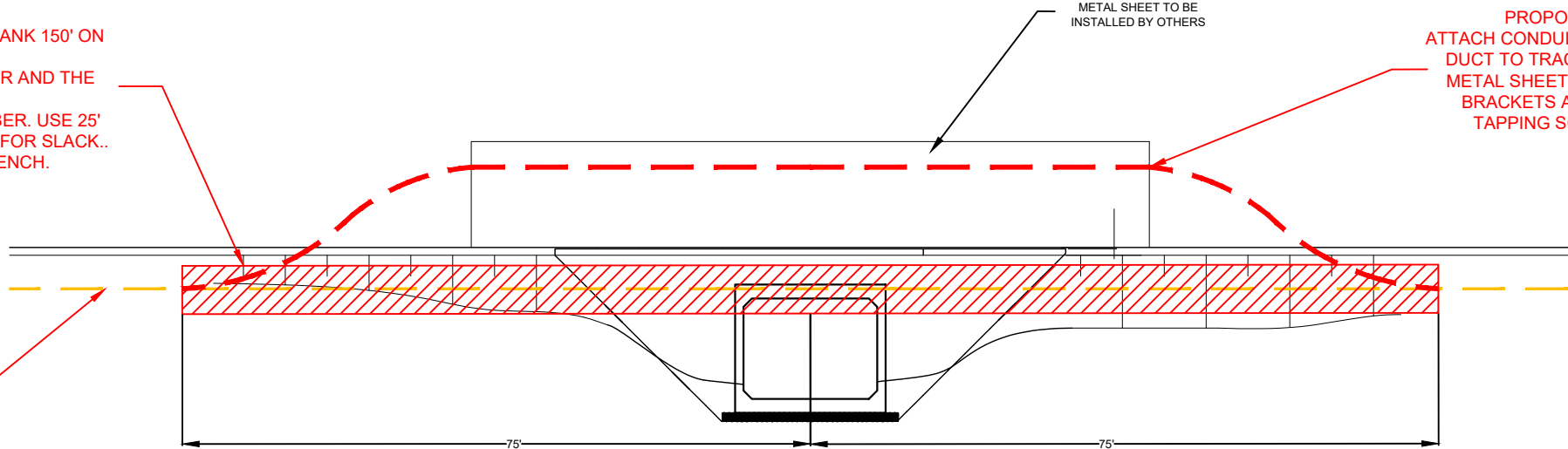

METAL SHEET TO BE INSTALLED BY OTHERS

PROPOSED
ATTACH CONDUIT WITH SPLIT DUCT TO TRACK SIDE OF METAL SHEET WITH PIPE BRACKETS AND SELF TAPPING SCREWS.

75'

75'

Under UCI project manager supervision , score existing conduit (with approved tools) , exposing existing 108ct live fiber leaving fiber intact , pull slack as needed from existing storage location, add split duct as needed and secure per design, in case the fiber is damaged during exposure STOP , do not proceed until appropriate UCI management is notified and that management has given the approval to continue.

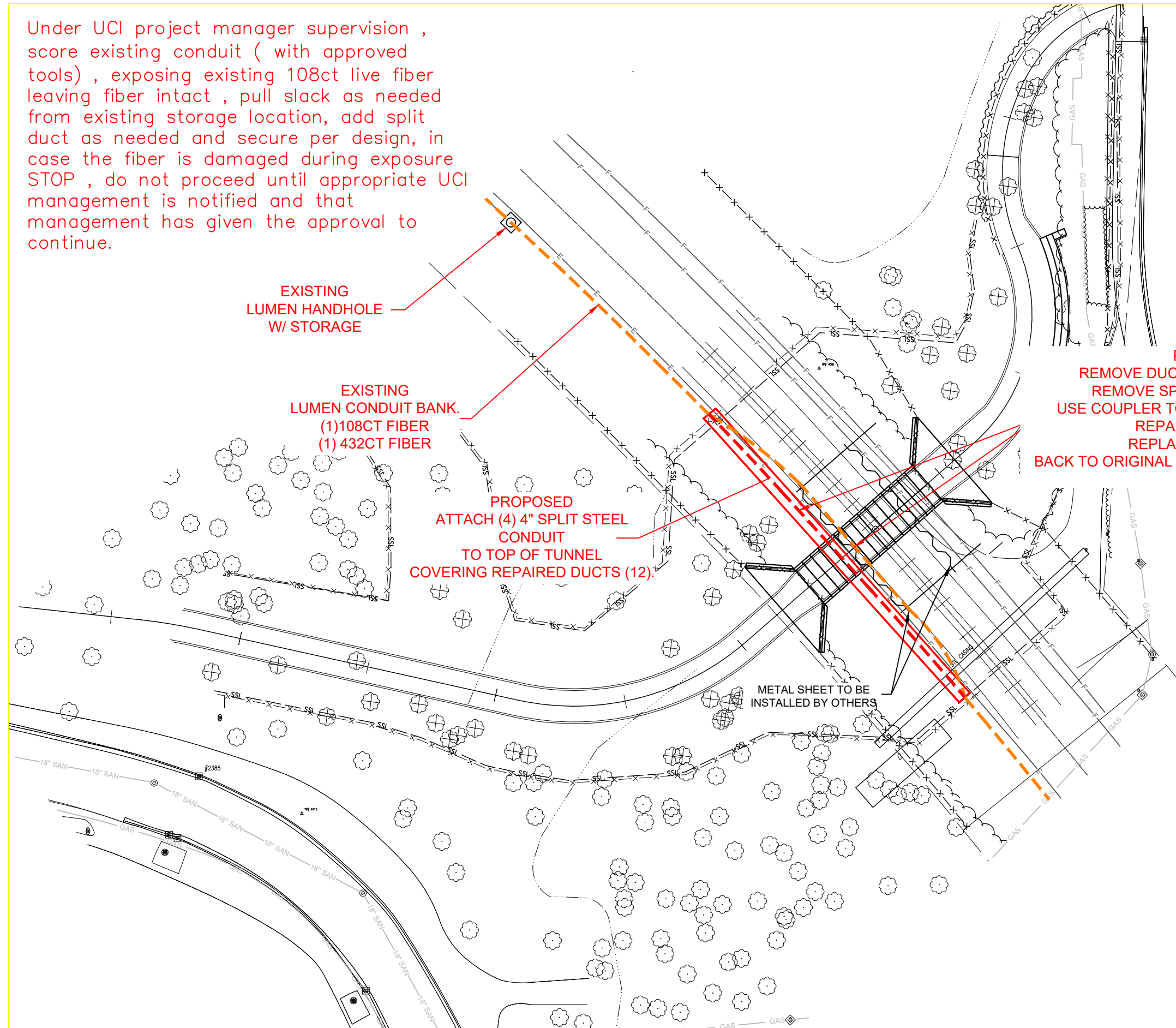

PROPOSED
 REMOVE DUCTS FROM METAL SHEET
 REMOVE SPLIT DUCT FROM 108CT.
 USE COUPLER TO MAKE ORIGINAL LENGTH.
 REPAIR 2 CUT DUCTS.
 REPLACE ALL 12 DUCTS
 BACK TO ORIGINAL LOCATION ON SOUTH SIDE OF
 TRACKS.



PROJECT: #24-04-0046

SEGMENT: SEG/SPAN

PHASE 2
 TO
 LUMEN - ANN ARBOR BIKE PATH



REVISIONS

DATE	DESCRIPTION	INITIAL

EXCEPT AS MAY BE OTHERWISE PROVIDED BY CONTRACT, THESE DRAWINGS AND SPECIFICATIONS SHALL REMAIN THE PROPERTY OF LEVEL3 COMMUNICATIONS. BEING ISSUED IN STRICT CONFIDENCE AND SHALL NOT BE REPRODUCED, COPIED, OR USED FOR ANY PURPOSE WITHOUT SPECIFIC WRITTEN PERMISSION.



Know what's below. Call before you dig.

LEVEL3 COMMUNICATIONS. IS NOT RESPONSIBLE FOR ANY UTILITY LOCATIONS SHOWN OR NOT SHOWN ON THIS DRAWING

PROPOSED
 ORIGINAL: 04/08/2024

REVISED:

SCALE
 B SIZE DWG: 1:40
 D SIZE DWG: 1:40

MP TO MP
 DWG. # LOCATION
 7 OF 9

**VIEW LOOKING NORTH EAST
SCALE 1:20**



PROJECT: #24-04-0046

SEGMENT: SEG/SPAN

PHASE 2
TO
LUMEN - ANN ARBOR BIKE PATH



REVISIONS

DATE	DESCRIPTION	INITIAL

EXCEPT AS MAY BE OTHERWISE PROVIDED BY CONTRACT, THESE DRAWINGS AND SPECIFICATIONS SHALL REMAIN THE PROPERTY OF LEVEL3 COMMUNICATIONS. BEING ISSUED IN STRICT CONFIDENCE AND SHALL NOT BE REPRODUCED, COPIED, OR USED FOR ANY PURPOSE WITHOUT SPECIFIC WRITTEN PERMISSION.



Know what's below.
Call before you dig.

LEVEL3 COMMUNICATIONS. IS NOT RESPONSIBLE FOR ANY UTILITY LOCATIONS SHOWN OR NOT SHOWN ON THIS DRAWING

PROPOSED
ORIGINAL: 04/08/2024

REVISED:

SCALE
B SIZE DWG: 1:40
D SIZE DWG: 1:40

MP TO MP

DWG. # LOCATION
8 OF 9

PROPOSED
REMOVE DUCT FROM METAL SHEET
REMOVE SPLIT DUCT FROM 108CT & 432CT.
USE COUPLER TO MAKE ORIGINAL LENGTH.
REPAIR 2 CUT DUCTS.
REPLACE ALL 12 DUCTS
BACK TO ORIGINAL LOCATION ON SOUTH SIDE OF
TRACKS.

METAL SHEET TO BE
INSTALLED BY OTHERS

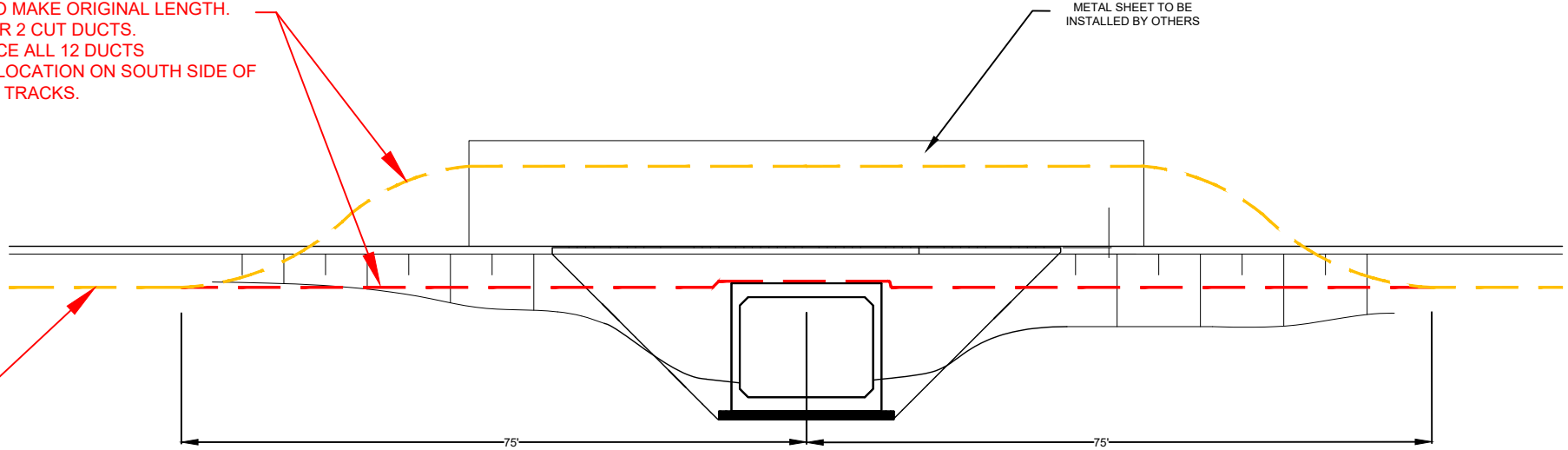

EXISTING
LUMEN 12 DUCT
CONDUIT BANK
(1) 108CT FIBER
(2) 432CT FIBER

PROPOSED
ATTACH 4" SPLIT STEEL CONDUIT
TO TOP OF TUNNEL
OVER REPAIRED DUCTS (12).

PROPOSED
4" STEEL
BRACKET

PROPOSED
4" SPLIT STEEL
CASING PIPE

EXISTING
LUMEN 12 DUCT
1.25" CONDUIT BANK
(1) 108CT FIBER
(2) 432CT FIBER

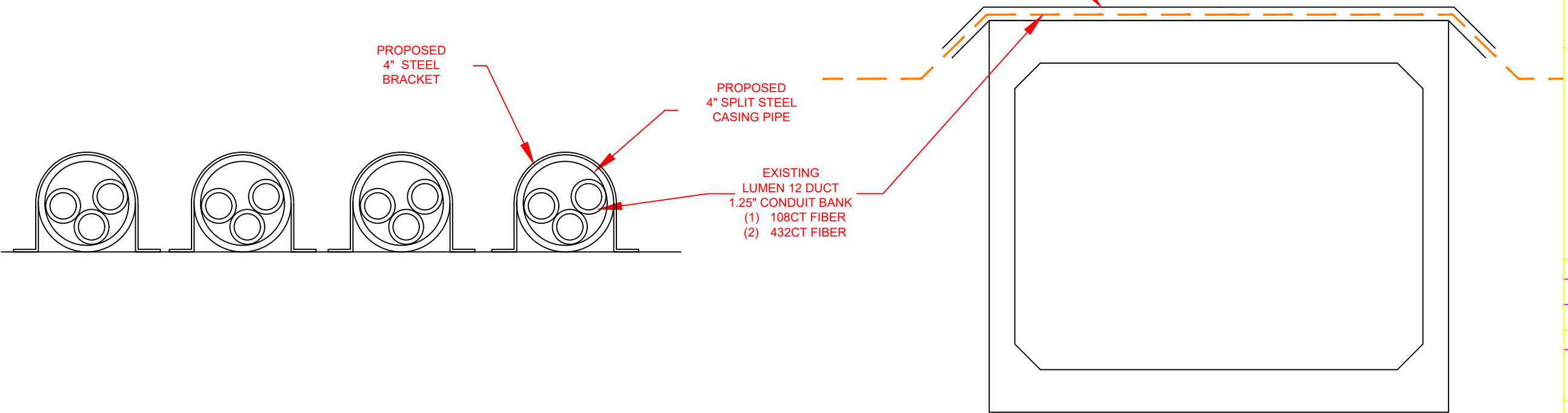

NTS



Total Underground Cost Unit			
Description	Units	Estimated Quantity	Actual Quantity
DIG & EXPOSE EXIST FACILITY	CU YD	150	
RMV BURIED FACILITY	FT	300	
RMV BURIED FACILITY <=48in ADDL FAC	FT	1500	
REPOSITION FIBER SLACK EXST CONDUIT	FT	300	
GROUND LAY CABLE	FT	300	
FACILITY ADJUSTMENT UNDERGROUND	FT	300	
PLUG EXISTING CONDUIT	EA	20	
REPAIR CONDUIT OR HDPE	FT	1500	
TUNNEL ATTACHMENT	FT	60	

Total Aerial Cost Unit			
Description	Units	Estimated Quantity	Actual Quantity

Total Interior Cost Unit			
Description	Units	Estimated Quantity	Actual Quantity

Total Material Cost Unit			
Description	Units	Estimated Quantity	Actual Quantity
INRDCT 1.25 SDR 11 ORANGE	FT	1500	
4" SPLIT STEEL PIPE	FT	60	
45 DEGREE 4" SPLIT STEEL PIPE	EACH	8	
FLEX SPLIT CONDUIT 1in-2in	FT	300	

PROJECT: #24-04-0046

SEGMENT: SEG/SPAN

PRE CONSTRUCTION PLANS
TO
LUMEN – ANN ARBOR BIKE PATH



REVISIONS

DATE	DESCRIPTION	INITIAL

EXCEPT AS MAY BE OTHERWISE PROVIDED BY CONTRACT, THESE DRAWINGS AND SPECIFICATIONS SHALL REMAIN THE PROPERTY OF LEVEL3 COMMUNICATIONS. BEING ISSUED IN STRICT CONFIDENCE AND SHALL NOT BE REPRODUCED, COPIED, OR USED FOR ANY PURPOSE WITHOUT SPECIFIC WRITTEN PERMISSION.



Know what's below.
Call before you dig.

LEVEL3 COMMUNICATIONS. IS NOT RESPONSIBLE FOR ANY UTILITY LOCATIONS SHOWN OR NOT SHOWN ON THIS DRAWING

PROPOSED

ORIGINAL: 04/08/2024

REVISED:

SCALE

B SIZE DWG: 1:40
D SIZE DWG: 1:40

MP TO MP

DWG. # LOCATION
9 OF 9