

ANN ARBOR HISTORIC DISTRICT COMMISSION

Staff Report

ADDRESS: 309 S Main Street, Application Number HDC20-166

DISTRICT: Main Street Historic District

REPORT DATE: November 12, 2020

REPORT PREPARED BY: Jill Thacher, Historic Preservation Coordinator

REVIEW COMMITTEE DATE: Monday, November 9, 2020

	OWNER	APPLICANT
Name:	309 S Main LLC	Multiverse Investments
Address:	309 S Main Street Ann Arbor, MI 48104	303 Detroit Street Suite 1 Ann Arbor, MI 48104
Phone:	(248) 910-9248	(734) 604-8806

BACKGROUND: The three-story building was constructed in 1866 in an Italianate vernacular style. It featured a prominent cornice and hooded arched windows. The original first floor tenant was Fred Gross Clothing.

In 1916 the front of the building was altered to its current yellow brick façade. Photos from the 1950s show the building covered in metal panels. The tenant was Dietzel's Shoe Store, and the storefront had recessed show windows on either side. After Dietzel's closed in 1987, the storefront was removed and boarded up. Note the second floor window configuration.

In January 1992, the Commission granted permission to remodel the storefront by bringing it out flush with the front of the building in a wood framed design that matched that of 311 S Main next door.

Certificates of Appropriateness were issued by the HDC at their February and April, 2008 meetings to rebuild the storefront. In 2010, the HDC approved a new roof deck exit stair on the rear elevation. In April of 2019, the HDC approved the replacement of four single and two triple vinyl windows on the front elevation with aluminum clad windows; and the replacement of the current wood storefront with an aluminum storefront system, two metal doors, and stone cladding surrounding the windows (HDC19-047). In August 2020, the HDC approved an alternate storefront (HDC20-122).

LOCATION: The site is located on the east side of South Main Street, south of E. Liberty and north of E. William.

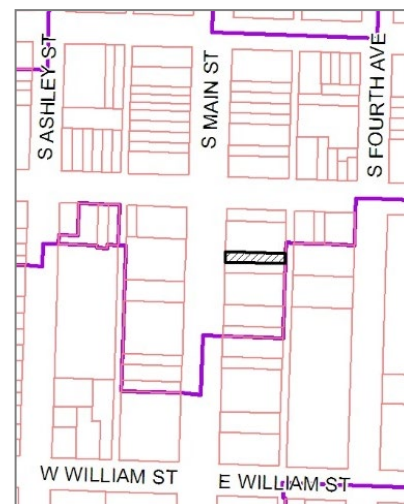

APPLICATION: The applicant seeks HDC approval to install a 1'5" x 12' wall sign above the storefront and a 30" x 22" pedestrian-scale blade sign.

APPLICABLE REGULATIONS:

From the Secretary of the Interior's Standards for Rehabilitation:

- (2) The historic character of a property will be retained and preserved. The removal of distinctive materials or alteration of features, spaces, and spatial relationships that characterize a property will be avoided.
- (9) New additions, exterior alterations, or related new construction shall not destroy historic materials that characterize the property. The new work shall be differentiated from the old and shall be compatible with the massing, size, scale, and architectural features to protect the historic integrity of the property and its environment.
- (10) New additions and adjacent or related new construction shall be undertaken in such a manner that if removed in the future, the essential form and integrity of the historic property and its environment would be unimpaired.

From the Secretary of the Interior's Guidelines for Rehabilitating Historic Buildings (other SOI Guidelines may also apply):

Storefronts

Not Recommended: Introducing a new design that is incompatible in size, scale, material, and color; using inappropriately scaled signs and logos or other types of signs that obscure, damage, or destroy remaining character-defining features of the historic building; using new illuminated signs.

From the Ann Arbor Historic District Design Guidelines:

Signs

Appropriate: Attaching signage through masonry joints or through materials that can be easily repaired, such as wood, when signage is removed.

Installing signage that is compatible in size, style, material, and appearance to the historic resource and district.

Installing signage that is subordinate to the overall building composition.

Pedestrian Scale Signs

Pedestrian scale signs should be: Located near the business's entry, at least 8' from the ground on the first floor.

Mounted on an arm or arms or hung from a bracket.

Aligned with similar signs on the block.

Sized not to exceed 4.5 square feet per side. This is roughly a 28" diameter circle, or 25" square. Odd shapes are welcomed and will be reviewed on a case by case basis.

STAFF FINDINGS:

1. A sign was previously approved that would fit inside a raised brick square above the storefront. In that application the dimensions of the square were incorrect (it is only 5.6" tall), and a new sign would need to be much smaller to fit inside than the one approved by the HDC. This application seeks to install a larger 1'5" tall by 12' wide sign through mortar joints. The sign would consist of an aluminum panel mounted away from the storefront brick, with halo-lit letters. It would fit in the 18.6" brick band above the storefront. The size and location are appropriate.
2. The pedestrian scale sign is shown at an appropriate height and alignment with nearby signs. It is 2'6" by 1'10" by 3" or 4.58 square feet. The sign is lit by pendant lights on either side. Staff is not concerned by the extra .08 square feet. If the Commission feels otherwise, staff will clarify the design guidelines for signs by changing the requirement to say "Sized not to exceed 4.50 square feet per side."
3. Staff believes the sign is appropriate and meets the *Ann Arbor Historic District Design Guidelines*, and the *Secretary of the Interior's Standards for Rehabilitation and Guidelines for Rehabilitating Historic Buildings*.

POSSIBLE MOTIONS: (Note that the motions are only a suggestion. The Review Committee, consisting of staff and at least two Commissioners, will visit the site and make a recommendation at the meeting.)

I move that the Commission issue a certificate of appropriateness for the application at 309 South Main Street, a contributing property in the Main Street Historic District, to install a new 17" x 12' wall sign and a 2'6" by 1'10" by 3" pedestrian scale sign, as proposed. The work is compatible in exterior design, arrangement, texture, material and relationship to the rest of the building and the surrounding area and meets the *Ann Arbor Historic District Design Guidelines* for signs, and *The Secretary of the Interior's Standards for Rehabilitation and Guidelines for Rehabilitating Historic Buildings*, in particular standards 2, 9 and 10, and the guidelines for storefronts.

MOTION WORKSHEET:

I move that the Commission issue a Certificate of Appropriateness for the work at 309 South Main Street in the Main Street Historic District

_____ Provided the following condition(S) is (ARE) met: 1) STATE CONDITION(s)

The work is generally compatible with the size, scale, massing, and materials and meets the Secretary of the Interior's Standards for Rehabilitation, standard(S) number(S) (*circle all that apply*): 1, 2, 3, 4, 5, 6, 7, 8, 9, 10

ATTACHMENTS: application, photos, drawings, lighting information.

309 S. Main (application photo)





HISTORIC DISTRICT COMMISSION

PLANNING AND DEVELOPMENT SERVICES

City Hall: 301 E. Huron St. Ann Arbor, MI 48104-6120

Mailing: P.O. Box 8647, Ann Arbor, MI 48107-8647

Phone: 734.794.6265 ext. 42608

ithacher@a2gov.org

Fax: 734.994.8460

OFFICE USE ONLY	
Permit Number	HDC# _____
	BLDG# _____
DATE STAMP	

APPLICATION MUST BE FILLED OUT COMPLETELY

PROPERTY LOCATION/OWNER INFORMATION

NAME OF PROPERTY OWNER 309 S Main LLC		HISTORIC DISTRICT Main Street	
PROPERTY ADDRESS 309 S Main Street			CITY ANN ARBOR
ZIPCODE 48104	DAYTIME PHONE NUMBER (248)9109248	EMAIL ADDRESS dejohnson78@hotmail.com	
PROPERTY OWNER'S ADDRESS (IF DIFFERENT FROM ABOVE) 1735 Fairview Court		CITY saline	STATE, ZIP 48176

PROPERTY OWNER'S SIGNATURE

SIGN HERE <i>Magdalena M. Gullerzon, trustee and it's manager</i>	PRINT NAME Magdalena M. Gullerzon trustee and it's manager	DATE 10-23-2020
--	---	------------------------

APPLICANT INFORMATION

NAME OF APPLICANT (IF DIFFERENT FROM ABOVE) Multiverse Investments			
ADDRESS OF APPLICANT 303 Detroit Street Suite 1			CITY Ann Arbor
STATE MI	ZIPCODE 48104	PHONE / CELL # (7346048806)	FAX No (N/A)
EMAIL ADDRESS mark@multiverseinvestments.com			

APPLICANT'S SIGNATURE (if different from Property Owner)

SIGN HERE <i>Mark Melchi</i>	PRINT NAME x Mark Melchi	DATE 10-23-20
-------------------------------------	---------------------------------	----------------------

BUILDING USE – CHECK ALL THAT APPLY

<input type="checkbox"/> SINGLE FAMILY	<input type="checkbox"/> DUPLEX	<input type="checkbox"/> RENTAL	<input type="checkbox"/> MULTIPLE FAMILY	<input checked="" type="checkbox"/> COMMERCIAL	<input type="checkbox"/> INSTITUTIONAL
--	---------------------------------	---------------------------------	--	--	--

PROPOSED WORK

Describe in detail each proposed exterior alteration, improvement and/or repair (use additional paper, if necessary).

Requesting approval to install two signs on a commercial building. Wall sign and blade sign. See attached application

DESCRIBE CONDITIONS THAT JUSTIFY THE PROPOSED CHANGES:

For the wall sign, the currently approved sign does not match the existing conditions of the building facade

The blade sign is requested to add additional branding and location information. It will match the size and style of other blade signs on the street

For Further Assistance With Required Attachments, please visit www.a2gov.org/hdc



HISTORIC DISTRICT COMMISSION APPLICATION

FEE CHART

DESCRIPTION	
STAFF REVIEW FEES	FEE
Application for Staff Approval	\$35.00
Work started without approvals	Additional \$50.00
HISTORIC DISTRICT COMMISSION FEES	
All other proposed work not listed below	\$100.00
Work started without approvals	Additional \$250.00
RESIDENTIAL – Single and 2-story Structure	
Addition: single story	\$300.00
Addition: taller than single story	\$550.00
New Structure - Accessory	\$100.00
New Structure – Principal	\$850.00
Replacement of single and 2-family window(s)	\$100 + \$25/window
COMMERCIAL – includes multi-family (3 or more unit) structures	
Additions	\$700.00
Replacement of multi-family and commercial window (s)	\$100 + \$50/window
Replacement of commercial storefront	\$250.00
DEMOLITION and RELOCATION	
Demolition of a contributing structure	\$1000.0
Demolition of a non-contributing structure	\$250.00
Relocation of a contributing structure	\$750.00
Relocation of a non-contributing structure	\$250.00

FOR COMMISSION REVIEWS:

- Application withdrawals made before public notice is published will qualify for a 50% refund of the application fee.
- Application withdrawals made after public notice is sent but before the public hearing will qualify for a 25% refund of the application fee.

INSTRUCTIONS FOR SUBMITTING APPLICATIONS

All HDC applications must be signed by the property owner and the applicant, if different, with the exception of staff approvals, which may be signed by only the applicant.

All completed HDC applications and their attachments may be submitted to Planning and Development Services by mail, in person (paper or digital), faxed, or via email to building@a2gov.org.

We accept CASH, CHECK, and all major credit cards. Checks should be made payable to "City of Ann Arbor"

HDC applications that are incomplete or not submitted with the required documentation or payment will not be processed or approved.

APPLICATION EXPIRATION

HDC applications expire three (3) years after the date of approval.

OFFICE USE ONLY

Date of Hearing:		
Action	<input type="checkbox"/> HDC COA	<input type="checkbox"/> HDC Denial
	<input type="checkbox"/> HDC NTP	<input type="checkbox"/> Staff COA
Staff Signature		
Comments		
Fee:	\$ _____	
Payment Type	<input type="checkbox"/> Check: # _____ <input type="checkbox"/> Cash <input type="checkbox"/> Credit Card	

309 South Main Street

Historic District Commission Application-Signage Upgrades

10.23.20 Revised 10.27.20

Attachment

309 South Main Street received HDC approval to reconstruct the first floor storefront under Project HDC20-122. The building is not currently occupied, and building ownership is anticipated to be transferred to the Applicant in November. A new user, Saganworks Labs, is currently planned to occupy the first floor.

This application pertains to proposed new exterior signage only. The currently approved sign for the building, which could be approved administratively, allows a 1' x 10' sign in the existing brick band above the storefront.

Proposed work on the front facade includes the following items:

Main Street-Modify approved wall sign area above storefront

Existing Condition:

There is a 7-brick course, 18.6" high horizontal band above the metal storefront and below the second-floor sills. The brick projects out approximately 3/4" to form a pocket that is 5.6" high between the courses. This is different than the dimensions and proportions shown on the previously approved application. See Figures 1 and 2

Proposed alteration:

A 1'-5" high by 12'-0" wide sign (17 SF) is proposed in the previously approved location. Letters to be stem mounted and halo lit on aluminum background panel, supports passing through mortar joints. See Figures 3 and 5

Conditions justifying the change:

The existing approved design does not depict the actual condition. If the sign was required to fit in the existing recess, it would be approximately 5" high. This would not be appropriate in scale to the building and surrounding signs, and would not be legible.

Main Street-Install new blade sign

Existing condition:

The existing building does not have a blade sign. Adjacent businesses have blade signs.

Proposed Alteration:

A new 2'-6" high by 1'-10" wide (4.5 SF) blade sign to be installed next to the building entrance. The bottom of the sign will be located at 9'-6" above the sidewalk. See Figures 4 and 5

Conditions justifying the change:

The blade sign will help to identify the building tenant, and match other retail uses along the street.

Note: See Figure 6 for photographs of existing conditions. Pendant light specs attached



Figure 1: Previously approved 1' x 10' sign

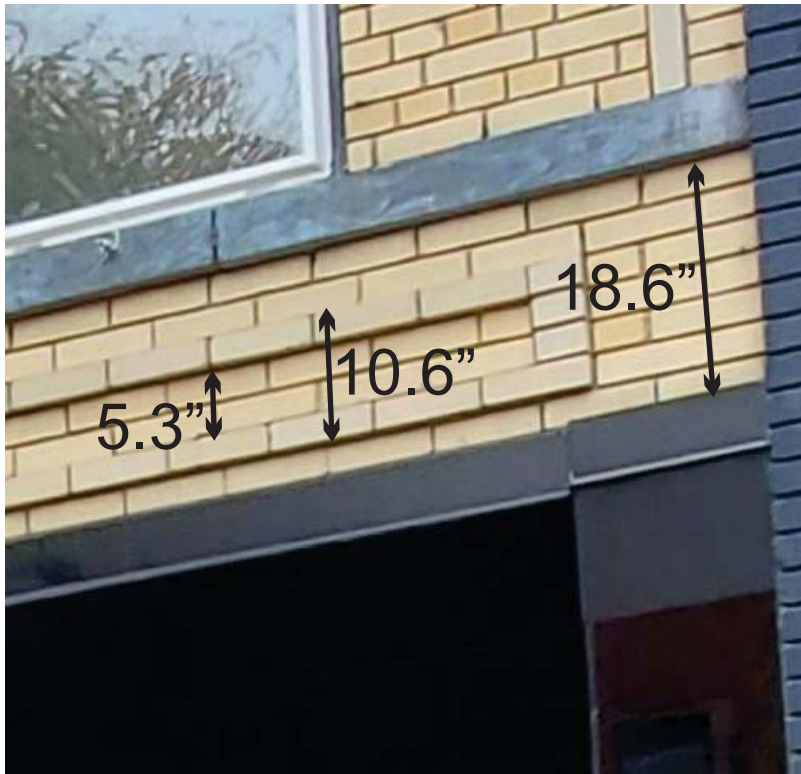

Figure 2: Actual condition

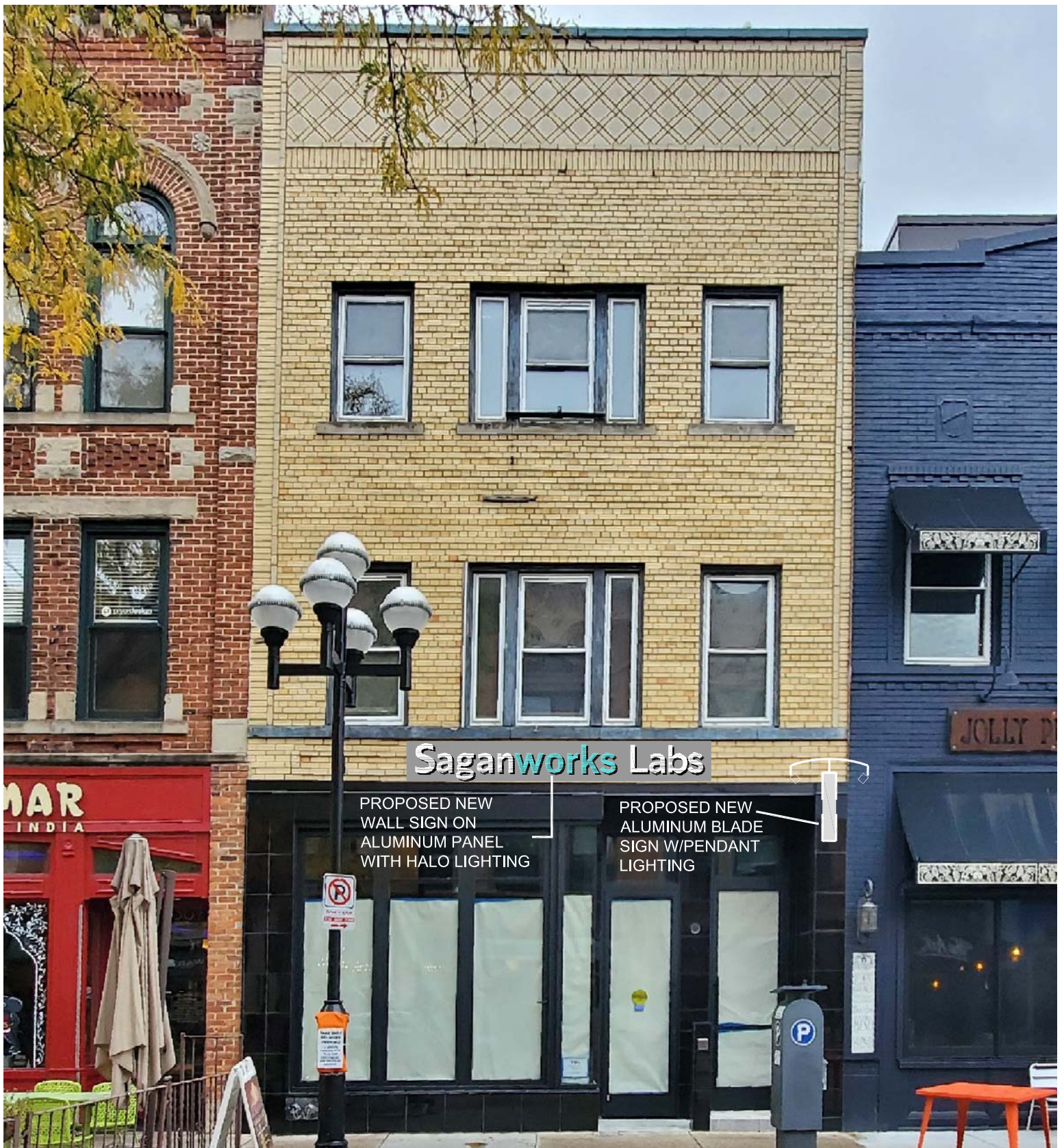

Figure 3: Proposed new wall sign

Note:

1. Lettering height is comparable to neighboring buildings
2. 1'-5" x 12'-0" aluminum sign panel mounted away from building surface, through mortar joints
3. Letters to be halo lit with LED strips, mounted away from sign panel surface
4. 'Saganworks Labs' shown as a placeholder. Request is for 1'-5" high by 12'-0" wide sign panel

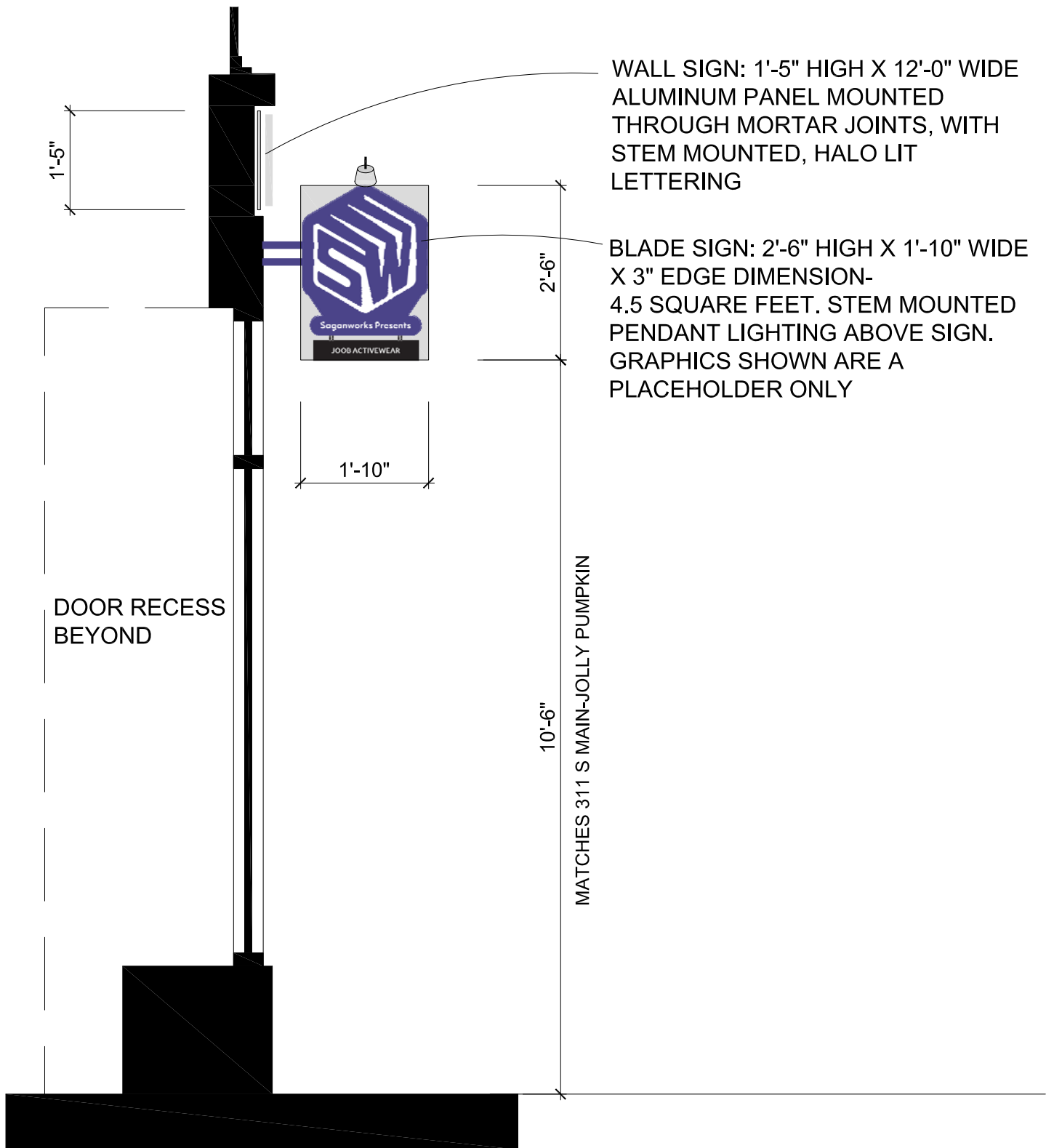

Figure 4: Wall Section at Proposed new Blade Sign

Note:

1. Blade sign size is comparable to neighboring buildings
2. Sign to be illuminated with pendant mounted fixtures
3. 'Saganworks' shown as a placeholder graphic



View Looking North



View Looking South

Figure 5: Street Level Views of Proposed New Signs



Existing Streetscape Elevation with Adjacent Signs



Looking South



Looking North

Figure 6: Existing Streetscape and Adjacent Signs



A- SHADES (CONTINUED)

SPECIALTY SHADES

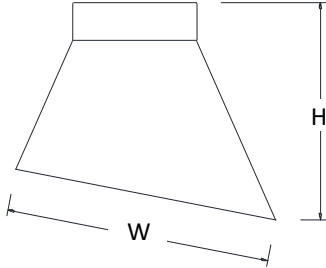

CSL7 HEIGHT WIDTH
 6.5" 8.5"

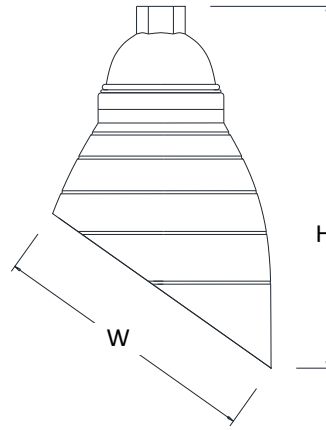

AC12 HEIGHT WIDTH
 8.25" 8"

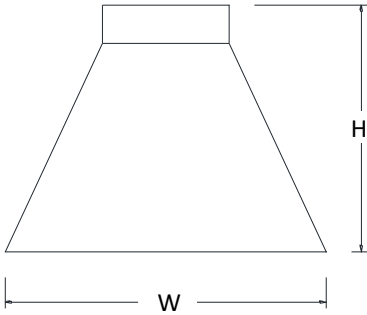

DSL9 HEIGHT WIDTH
 7.25" 9.5"



DSL12 HEIGHT WIDTH
 4.5" 12"

K SERIES

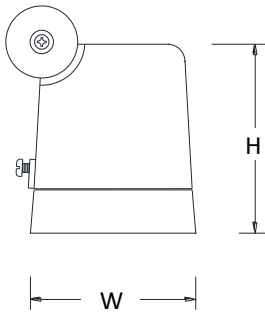

K1 HEIGHT WIDTH
 3.25" 2.875"

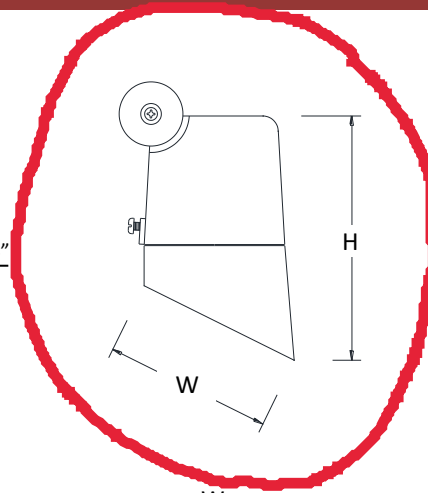

K2 HEIGHT WIDTH
 4.75" 3.25"

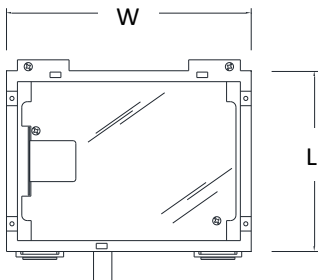

K3 HEIGHT WIDTH LENGTH
 5.5" 9" 6.625"

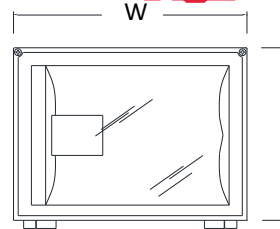
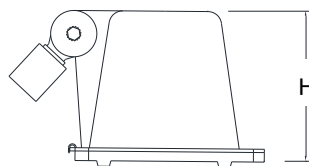

K4 HEIGHT WIDTH LENGTH
 8" 11.5" 8.5"

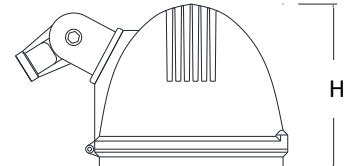



B- FINISHES

BASELITE USES A DURABLE POWDER COATING TO FINISH THEIR SHADES. THE POWDER COATING PROCESS ALLOWS THE SHADES TO HAVE A THICKER COATING OF PAINT, WHICH ENSURES A HIGHER QUALITY PROTECTIVE COATING. BASELITE OFFERS A WIDE RANGE OF COLORS TO CHOOSE FROM. CALL FOR CUSTOM COLOR OPTIONS.



40- COPPER W/
CLEAR COAT



41-GLOSS BLACK



42-DARK GREEN



43-RED

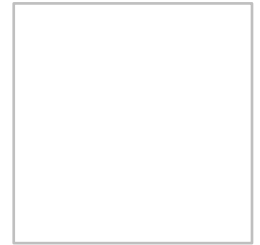

44-WHITE



45-MEDIUM BLUE



46-YELLOW



48-POLISHED
ALUMINUM

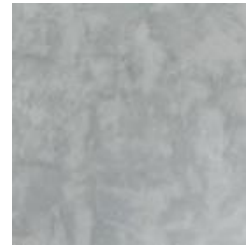

49-GALVANIZED



50-NAVY BLUE

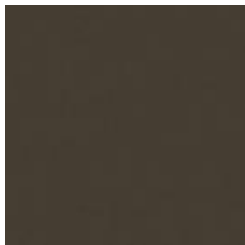

51-ARCHITECTURAL
BRONZE



52-PATINA

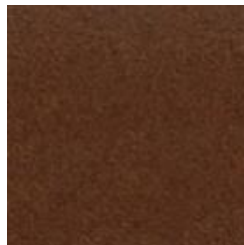

53-RUST

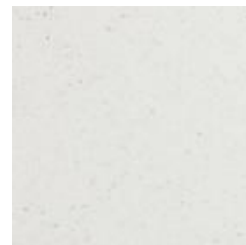

54-STUCCO



55-SAGE

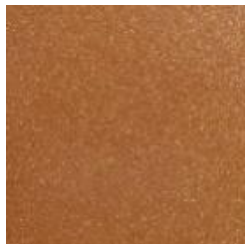

59-COPPER
TONE



60-CANAL GREEN

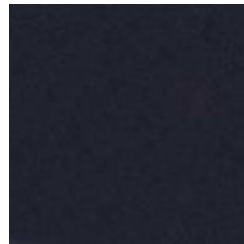

61-ANODIZED
CHARCOAL

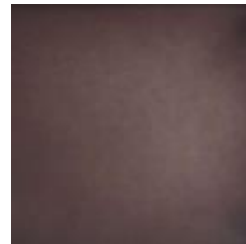

62-ANODIZED
BRONZE

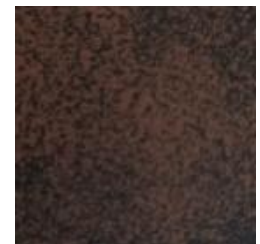

63-IRON RUST

B – FINISH OPTIONS NOTES

*ALL FINISH COLORS FEATURE A WHITE INTERIOR, EXCLUDING FINISH COLORS 61 AND 62. THESE COLORS ARE PAINTED THE SAME COLOR INSIDE AND OUT OF THE SHADE.



C-MOUNTING OPTIONS (CONTINUED)

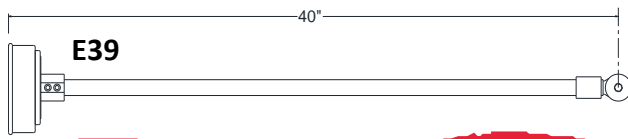
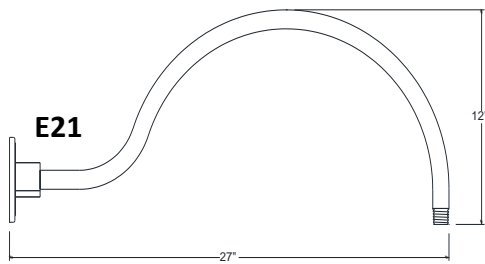
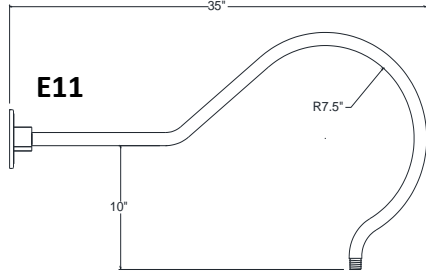
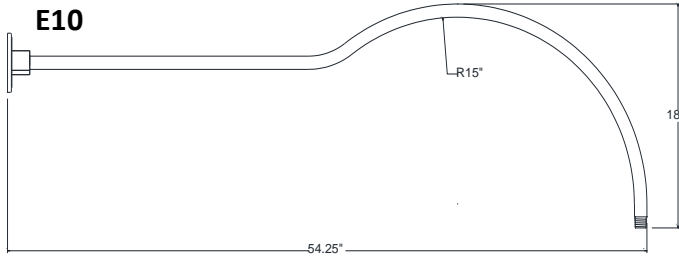

*K SERIES ONLY

E38

*K SERIES ONLY

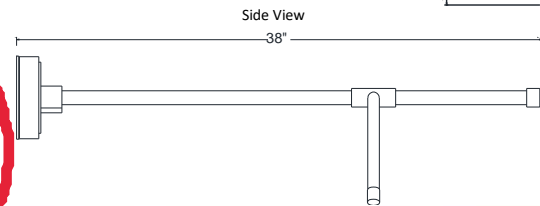
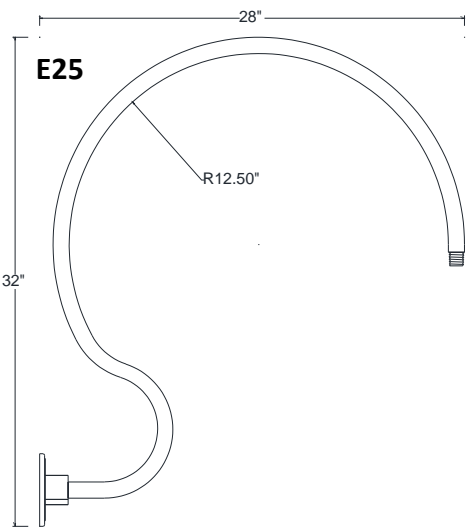
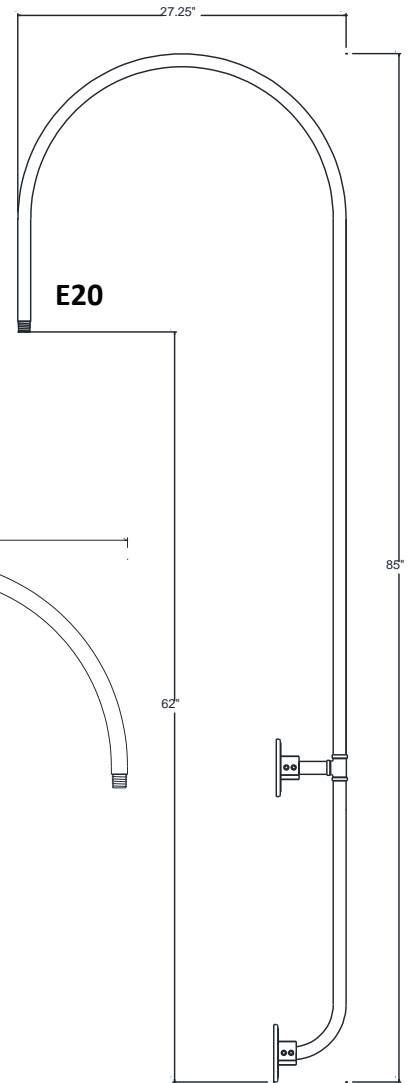
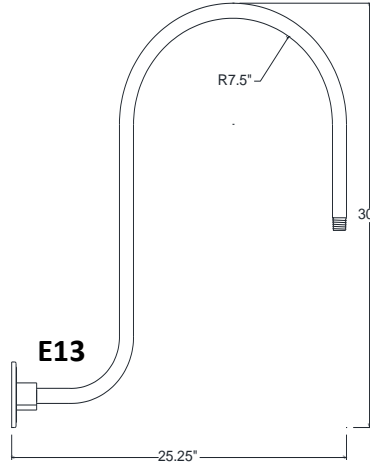
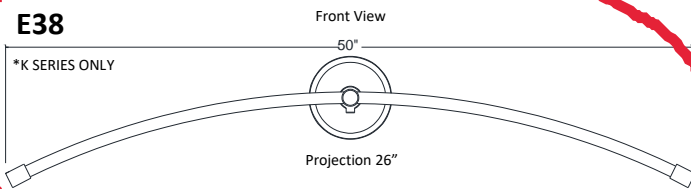

D- MOUNTING ADD-ONS

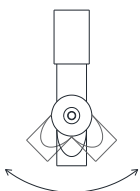

SMSWL 1/2" NPT swivel
For all arms 7" wide in diameter or smaller

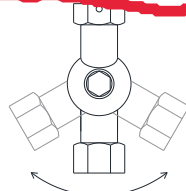

LGSWL 1/2" NPT swivel
For all arms greater than 7" wide in diameter

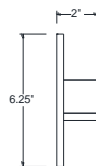

SQ 1/2" Square Backplate
SQ 3/4" Square Backplate
(Additional charges may apply)

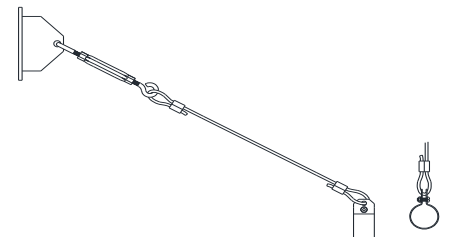
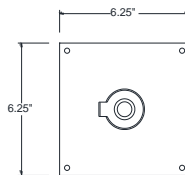

TRB 1/2"-4' Cable Support
TRB 3/4"-4' Cable Support



F – LIGHT SOURCE

BASELITE'S PUBLISHED LUMINAIRE PHOTOMETRIC TESTING WAS PERFORMED IN A 3-METER INTEGRATING SPHERE USING THE 4TT GEOMETRY METHOD. DATA IS CONSIDERED TO BE REPRESENTATIVE OF THE CONFIGURATIONS SHOWN, WITHIN THE TOLERANCES ALLOWED BY LIGHTING FACTS. TO OBTAIN AN IES FILE SPECIFIC TO YOUR PROJECT, PLEASE CONTACT THE FACTORY.

OPTION	WATTAGE	LUMENS		CRI	VOLTAGE	DIMMING
LEDS (LED)						
LED12W	12W	1068	1163	>90	120-277 VAC	0-10V
LED25W	25W	1906	2025	>90	120-277 VAC	0-10V
		@3000K	@5000K			
<p><i>*IMPORTANT – FOR LED (LED) LIGHT SOURCE OPTION FIXTURES ARE LIMITED DUE TO SIZE OF THE FIXTURE AND THE CORD WATTAGE RESTRICTIONS. PLEASE SEE AVAILABILITY CHART TO THE RIGHT.</i></p> <p>EXAMPLE: / LED25W /</p>		<p>LED 12W (MAX) – A807, A810, DS07, DS10, M707, M710, M710S, CN08, ELA10, AC12, CSL7, DSL9, K1, K2, K3, K4 LED 25W (MAX) – A812, A814, DS12, DS14, M712, M718, CN12, CN14, ELA12, ELA14, DSL12</p>				

OPTION	WATTAGE	LUMENS	CRI	VOLTAGE	DIMMING
INCANDESCENT (INC) <small>MED E26</small>					
100WINC	100W	PER BULB SPECS	>90	120-277 VAC	N/A
150WINC	150W	PER BULB SPECS	>90	120-277 VAC	N/A
200WINC	200W	PER BULB SPECS	>90	120-277 VAC	N/A
<p><i>*IMPORTANT – FOR INCANDESCENT (INC) LIGHT SOURCE OPTION, FIXTURES ARE LIMITED DUE TO SIZE OF THE FIXTURE AND THE CORD WATTAGE RESTRICTIONS. PLEASE SEE AVAILABILITY CHART TO THE RIGHT.</i></p> <p>EXAMPLE: / 150WINC /</p>			<p>100WINC (MAX) – A807, M707, DS07, CN08, CSL7, ELA10, K1, K2, K3, K4 150WINC (MAX) – A810, M710, DS10, CN12, DSL9, ELA12, 200WINC (MAX) – A812, A814, M712, M718, DS12, DS14, CN14, DS12, AC12, ELA14</p>		

OPTION	WATTAGE	LUMENS	CRI	VOLTAGE	DIMMING
COMPACT FLOURESCENT (CF)					
CF26W	26W	PER BULB SPECS	>90	120-277 VAC	0-10V
CF32W	32W	PER BULB SPECS	>90	120-277 VAC	0-10V
CF42W	42W	PER BULB SPECS	>90	120-277 VAC	0-10V
<p><i>*IMPORTANT – FOR INCANDESCENT (INC) LIGHT SOURCE OPTION, FIXTURES ARE LIMITED DUE TO SIZE OF THE FIXTURE AND THE CORD WATTAGE RESTRICTIONS. PLEASE SEE AVAILABILITY CHART TO THE RIGHT.</i></p> <p>EXAMPLE: / 4X42W /</p>			<p>26W (MAX) – A807, M707, DS07, CN08, CSL7, ELA10 26W, 32W or 42W (MAX) – A810, A812, A814, M710, M712, M718, DS10, DS12, DS14, CN12, CN14, DSL9, DS12, AC12, ELA12, ELA14, K3, K4</p>		

OPTION	WATTAGE	LUMENS	CRI	VOLTAGE	DIMMING
HIGH INTENSITY DISCHARGE (HID)					
35WMH	35W	PER BULB SPECS	>90	120-277 VAC	N/A
50WMH	50W	PER BULB SPECS	>90	120-277 VAC	N/A
70WMH	70W	PER BULB SPECS	>90	120-277 VAC	N/A
100WMH	100W	PER BULB SPECS	>90	120-277 VAC	N/A
<p><i>*IMPORTANT – FOR METAL HALIDE (HID) LIGHT SOURCE OPTION FIXTURES ARE LIMITED DUE TO SIZE, PLEASE SEE AVAILABILITY CHART TO THE RIGHT.</i></p> <p>EXAMPLE: / 100WMH /</p>			<p>35W OR 50W (MAX) – A807, M707, DS07, CN08, CSL7, ELA10 35W, 50W, 75W or 100W (MAX) – A810, A812, A814, M710, M712, M718, DS10, DS12, DS14, CN12, CN14, DSL9, DS12, AC12, ELA12, ELA14, K3, K4</p>		

MR16 – 50W					
MR16-50W	50W	PER BULB SPECS	>90	120 VAC	N/A
<p><i>*IMPORTANT – MR16-50W LIGHT SOURCE OPTION FIXTURES ARE LIMITED DUE TO SIZE, PLEASE SEE AVAILABILITY CHART TO THE RIGHT.</i></p> <p>EXAMPLE: / MR16-50W /</p>			<p>MR16-50W – K1, K2</p>		

Required information for applications for new signs in Historic Districts

- Completed Historic District Commission Application, signed by property owner (not business owner)
- Photo(s) of existing conditions
- Rendering of proposed sign, including materials and dimensions
- Mounting description
- Illustration of proposed sign on the building (superimposed on a photo(s) or elevation drawing(s)) including distance from ground and nearby architectural features if appropriate
- Illustration showing alignment with neighboring storefront signs or design elements (photo(s) or drawing(s))

General information:

- Signs may not be internally illuminated.
- Signs must be mounted through masonry joints, not masonry units (brick/block/stone). This must be noted on drawings when applicable.
- Pedestrian scale blade/bracket signs must not exceed 4.5 square feet per face.
- A [Sign Permit](#) is required.