

**From:** Amy Crawford

**Sent:** Tuesday, February 28, 2017 4:20 PM

**To:** Planning <[Planning@a2gov.org](mailto:Planning@a2gov.org)>

**Subject:** A neighbor's statement re. Circle K Redevelopment at Stadium and Packard

Dear Planning Commission,

We are among the neighbors who will be affected by the redevelopment of the Circle K gas station at East Stadium and Packard, and we are writing to express our support for the alternative plan (the one presented to the neighbors by Circle K and Quatro on 2/22 with Brett Lenart in attendance; see attached PDF). While it is still not ideal, we believe that this plan will have a far less harmful impact on our end of Iroquois Place than the current by-right plan.

Our primary concern with regard to the redevelopment is the impact of light, noise and traffic fumes on our home and those of our nearest neighbors. The alternative plan has vehicles and lights farther away from residences, and it preserves more trees as a buffer. It is also superior when it comes to pedestrian safety-- an important factor at an already-dangerous intersection.

We understand that the alternative plan will require a zoning variance to build a portion of the new building within the 30-foot residential buffer zone, and we pledge to support such a variance when the developers seek it.

Thank you very much for your continuing work on this.

Amy Crawford and Dmitry Berenson  
1418 Iroquois Place  
Ann Arbor, MI 48104

518-321-4525

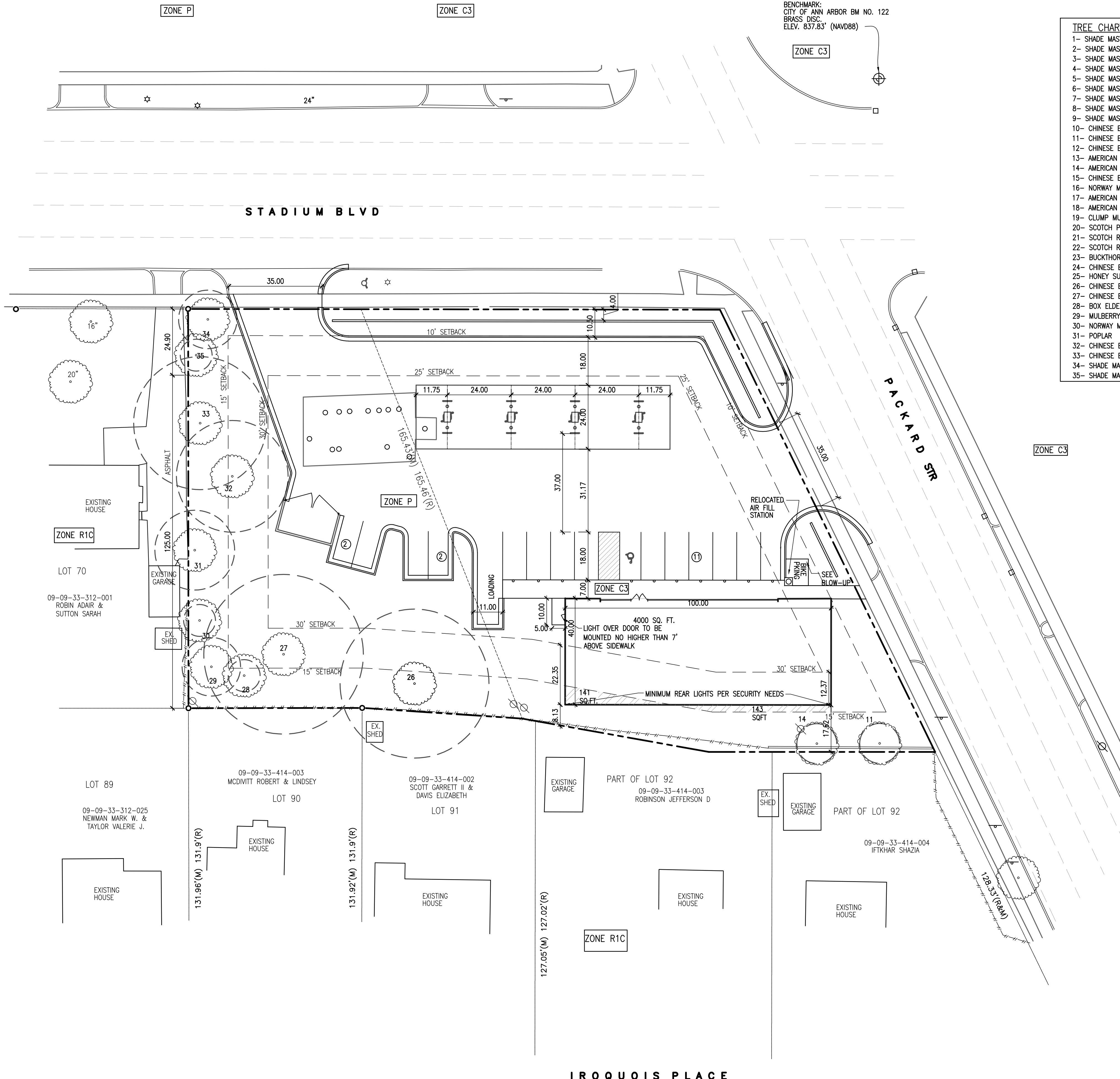

BENCHMARK:  
CITY OF ANN ARBOR BM NO. 122  
BRASS DISC  
ELEV. 837.83' (NAVD88)

TREE CHART	LM	DBH	CONDITION	KEPT/REMOVE/RELOCATE
1- SHADE MASTER HONEYLOCUST 10" CAL	N	11.5"	GOOD	1- REMOVE
2- SHADE MASTER HONEYLOCUST 10" CAL	N	8.5"	GOOD	2- REMOVE
3- SHADE MASTER HONEYLOCUST 10" CAL	N	9"	GOOD	3- REMOVE
4- SHADE MASTER HONEYLOCUST 10" CAL	N	8"	GOOD	4- REMOVE
5- SHADE MASTER HONEYLOCUST 10" CAL	N	10.2"	GOOD	5- REMOVE
6- SHADE MASTER HONEYLOCUST 10" CAL	N	8"	GOOD	6- REMOVE
7- SHADE MASTER HONEYLOCUST 10" CAL	N	9"	GOOD	7- REMOVE
8- SHADE MASTER HONEYLOCUST 10" CAL	N	10"	GOOD	8- REMOVE
9- SHADE MASTER HONEYLOCUST 12" CAL	N	11"	GOOD	9- REMOVE
10- CHINESE ELM 12" CAL	Y	20"	FAIR	10- REMOVE
11- CHINESE ELM 10" CAL	N	7.5"	FAIR	11- KEPT
12- CHINESE ELM 16" CAL	N	13"	FAIR	12- REMOVE
13- AMERICAN ELM 12" CAL	N	17"	POOR	13- REMOVE
14- AMERICAN ELM 8" CAL	N	11.5"	FAIR	14- KEPT
15- CHINESE ELM 16" CAL	Y	19"	FAIR	15- REMOVE
16- NORWAY MAPLE 6" CAL	N	6"	DEAD	16- REMOVE
17- AMERICAN ELM 8" CAL	N	10"	FAIR	17- REMOVE
18- AMERICAN ELM 16" CAL	N	9"	FAIR	18- REMOVE
19- CLUMP MULBERRY - 4"-8" CAL	N	8"	GOOD	19- REMOVE
20- SCOTCH PINE 20" CAL	Y	18"	GOOD	20- REMOVE
21- SCOTCH RED PINE 20" CAL	N	16"	GOOD	21- REMOVE
22- SCOTCH RED PINE 12" CAL	N	14"	GOOD	22- REMOVE
23- BUCKTHORN 6" CAL	N	6"	POOR	23- REMOVE
24- CHINESE ELM 70" CAL	Y	32"	GOOD	24- REMOVE
25- HONEY SUCKLE SHRUB	N	SHRUB		25- SHRUB KEPT
26- CHINESE ELM 40" CAL	Y	28"	FAIR	26- KEPT
27- CHINESE ELM 60" CAL	Y	30"	FAIR	27- KEPT
28- BOX ELDER 2-6" CAL	N	2"	GOOD	28- KEPT
29- MULBERRY 26" CAL	N	11"	FAIR	29- KEPT
30- NORWAY MAPLE 6" CAL	N	6"	GOOD	30- KEPT
31- POPLAR 18" CAL	N	15"	GOOD	31- KEPT
32- CHINESE ELM 24" CAL	Y	21"	FAIR	32- KEPT
33- CHINESE ELM 26" CAL	Y	25"	FAIR	33- KEPT
34- SHADE MASTER HONEY LOCUST 14" CAL	N	11"	GOOD	34- KEPT
35- SHADE MASTER HONEY LOCUST 6" CAL	N	3"	GOOD	35- KEPT

DESCRIPTION	REQUIRED	EXISTING	PROPOSED	NOTE
ZONING	C3	P/C3	P/C3	
FRONT YARD-BLDG	10.00/25.00	45.85/44.90	10/10	
SIDE YARD	30.00	119.95	48	
REAR YARD	30.00/30.00	119.95/62.40	SPEC	VARIANCE REQ.
PARKING	20	13 PK 8 PUMP	15 PK 8 PUMP	
PARKING SPACE	9x18	9x18	9x18	
HC PARKING	1	1	1	
PARKING AISLE	22.0	22.0	22-36	
BICYCLE PARKING	1C	0	2C	SERVICES 2 BIKES
MAXIMUM HEIGHT	55	15.4	19.2	
STORIES	4 MAX	1	1	
MIN SITE AREA	6000	37,589 SQFT	37,589 SQFT	
MAX FLOOR RATIO	200%	6.3%	10.0%	
MIN WIDTH	60	150	150	
BLD AREA		2360	4000	

PARKING CALCULATIONS:  
1 SPACE PER 200 SQ.FT. OF FLOOR AREA:  
4000/200 = 20 SPACES REQUIRED

HOURS OF OPERATION: 24 HR

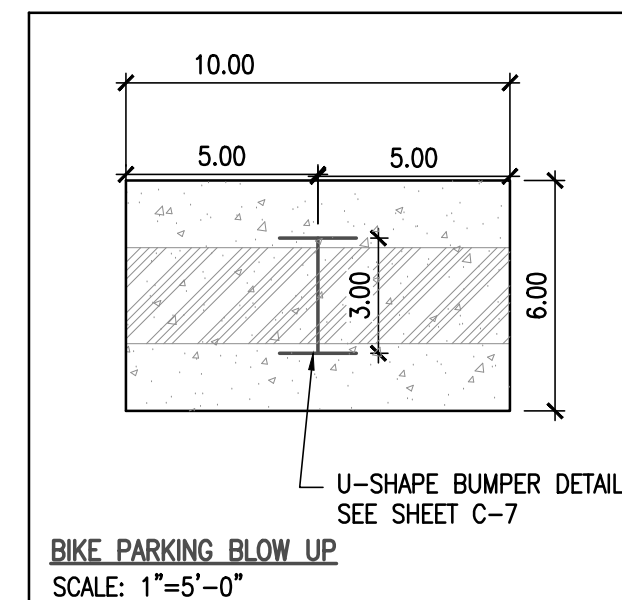

THIS DRAWING IS AND SHALL REMAIN THE PROPERTY OF QUATRO CONSTRUCTION LLC. USE, REPRODUCTION OR ALTERATION OF ANY KIND WITHOUT THE EXPRESSED WRITTEN PERMISSION OF QUATRO CONSTRUCTION LLC, IS PROHIBITED BY LAW.

**ROBERT NOE**  
ARCHITECTURE  
9103 N UNION #135  
YPSILANTI, MI 48198  
TEL: (734) 485-7873  
FAX: (734) 693-0852

**QUATRO CONSTRUCTION LLC**  
\*DESIGN BUILD CONTRACTOR\*  
COMMERCIAL/INDUSTRIAL/RESIDENTIAL  
201 NORTH PARK STREET  
YPSILANTI, MI 48198  
PHONE (734) 485-7737, FAX (734) 485-7873

**CIRCLE-K GAS STATION**  
1420 EAST STADIUM BLVD  
ANN ARBOR, MI 48104

ISSUE DATE
2/19/15
2/23/15
5/3/15
5/27/15
9/24/15
12/10/15
12/24/15
12/28/15
01/04/16
01/22/16
02/22/16
03/09/16
04/12/16
04/25/16
05/03/16
06/09/16
06/16/16
07/12/16
07/29/16
11/02/16
12/23/16
02/06/17

DRAWN BY: R.S.  
CHECKED BY: R.N.  
APPROVED BY: R.N./T.Q.

ARCHITECTURAL SEAL:

PROJECT NO.: **2621**

SHEET TITLE:

SHEET NO.:

72 HOURS BEFORE YOU DIG CALL MISS DIG 1-800-482-7171 (TOLL FREE)

NORTH SCALE 1"=20'