

# Quality gas. Trusted for over 100 years.



## CANOPY SITE INFO

**JOBBER:** RPF OIL COMPANY

**ADDRESS:** 2375 S Grove Rd,  
Ypsilanti, MI 48198-9268

**SVB:** 2474300

**PM:** Tatum Geselter

**DATE:** 04.16.2024

**REVISION #:** ORIGINAL

**DESIGNER:** ERIC STARK



Approved By: \_\_\_\_\_

Sign off indicates that the above [product has been permitted any municipalities involved. By signing this document, the product will be manufactured to these specifications.



Front Elevation

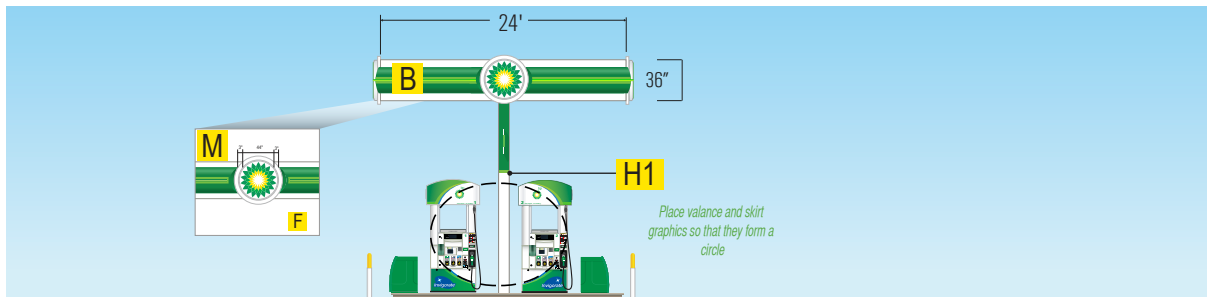

Left Elevation

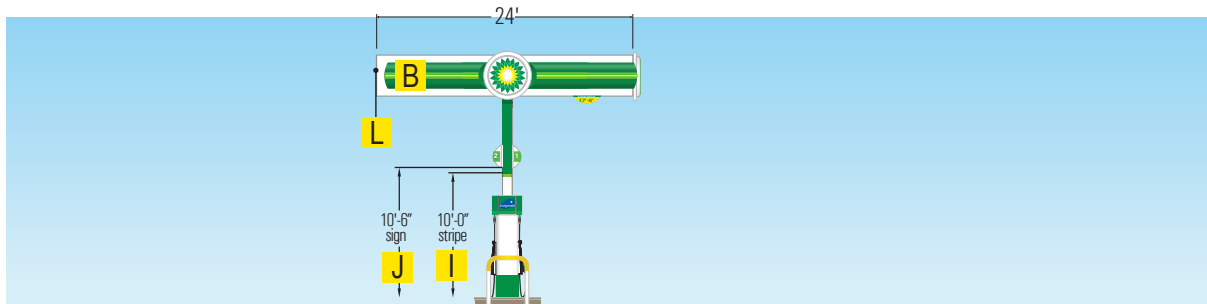

NO IMAGE AVAILABLE

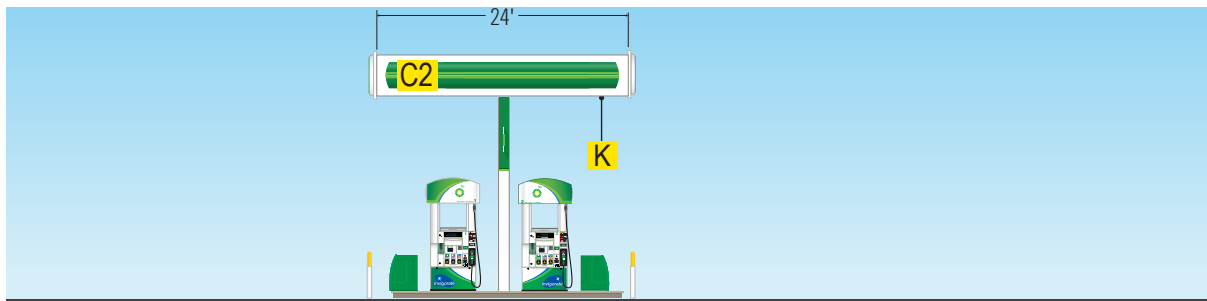

Back Elevation



Right Elevation

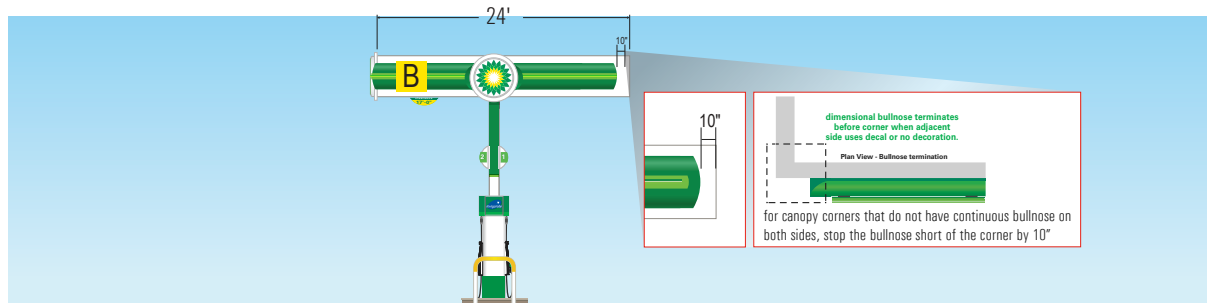

See Site Notes page for specific paint codes and contact info.

**\*REMOVE ALL EXISTING SIGNAGE\***

- B**  Install Dimensional Bullnose Fascia With Light Bar
- C1**  Install Dimensional Bullnose Fascia With No Light Bar
- C2**  Install BGB Flat ACM With Decal Applied With No Light Bar
- D**  Install New White ACM
  - Jobber Supplied
  - Federal Heath Supplied
- E**  Paint Existing Flat ACM White
  - Install Bullnose Decal
  - Leave White
- F**  Install Helios With Arc Kit
  - 39" Helios
  - 30" Helios (restricted P&Z only)
  - 44" Helios
  - 36" Helios (restricted P&Z only)
- G**  Install Helios Without Arc Kit
  - 39" Helios
  - 30" Helios (restricted P&Z only)
  - 44" Helios
  - 36" Helios (restricted P&Z only)
- H1**  Paint Canopy Columns White/BP Green, & Install Column Decal  
(Per Standards Shown on Note Page)
- H2**  Image As Shown In Concepts
- I**  Install Flag Signs 10'6" From The Ground
- J**  Apply BP Light Green Stripe 10'0" From The Ground
- K**  Canopy Deck To Be BP White
- L**  Canopy Corners:  Are 90°  Are NOT 90°
- M**  Canopy Detail (Full Canopy Detail Page After Elevation)

**NOTES:**

**FOR A TWO TIER FASCIA, PLEASE REMOVE ALL LAYERS OF FASCIA AND TAKE IT BACK TO THE DECK. THEN BUILD THE FASCIA HEIGHT TO 36".**

**MAP:**

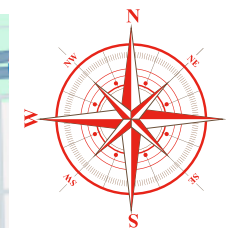
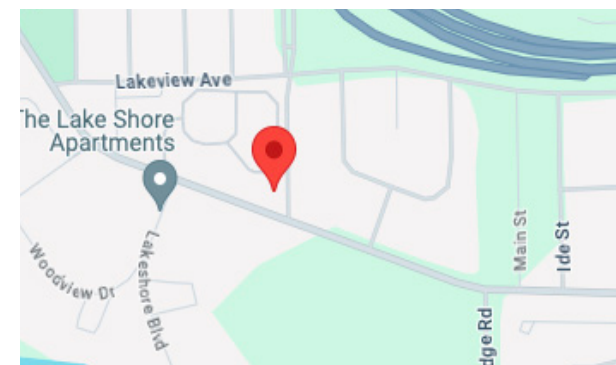

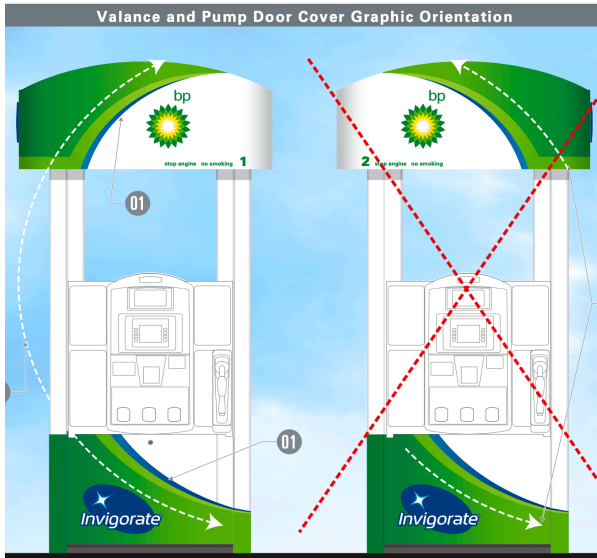
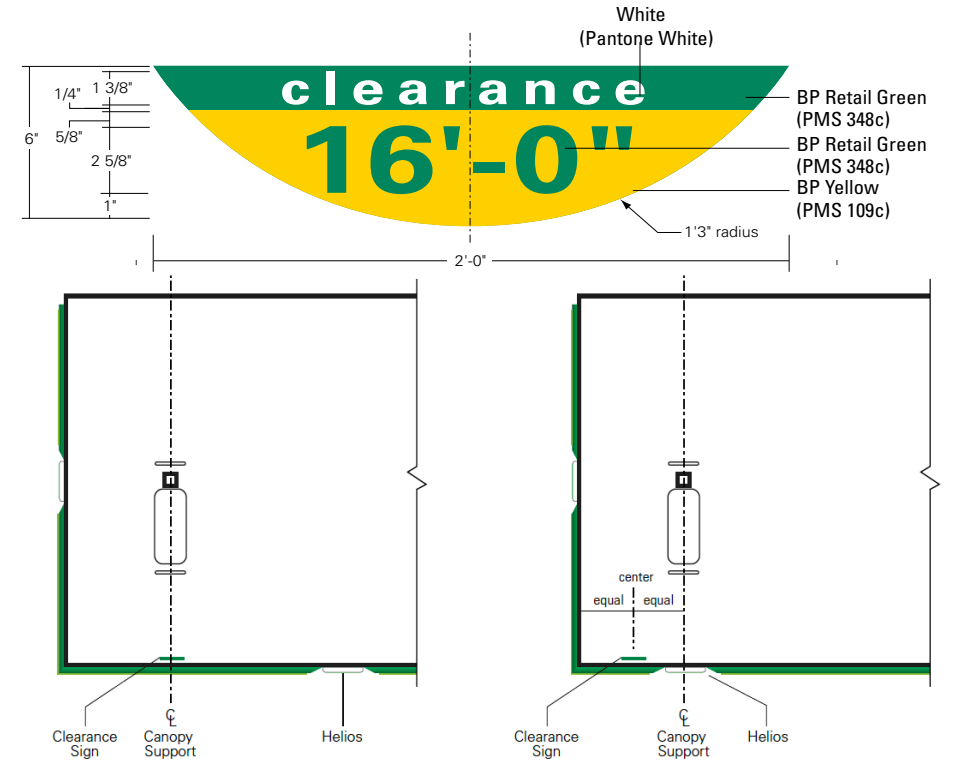
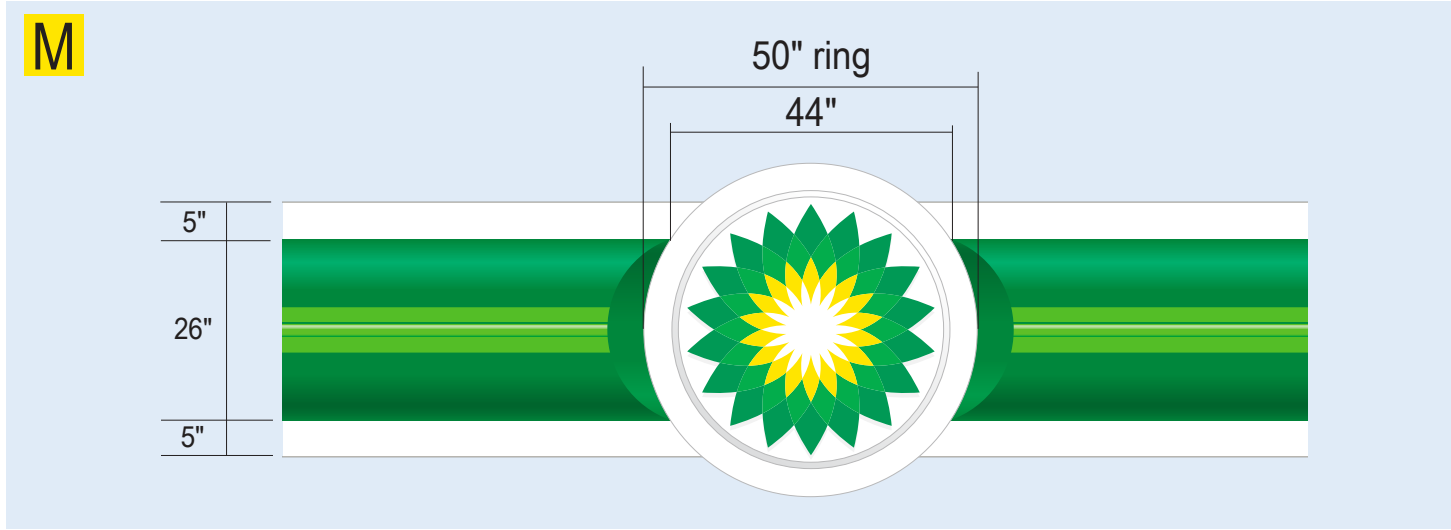

Correct orientation. Swoosh graphic on valance and door cover match. Do not install valance and door cover in opposite graphic directions.

TYPICAL FOR ALL GASOLINE AND DIESEL DISPENSERS



Note: Any deviation from nozzle covers MUST have BP approval.

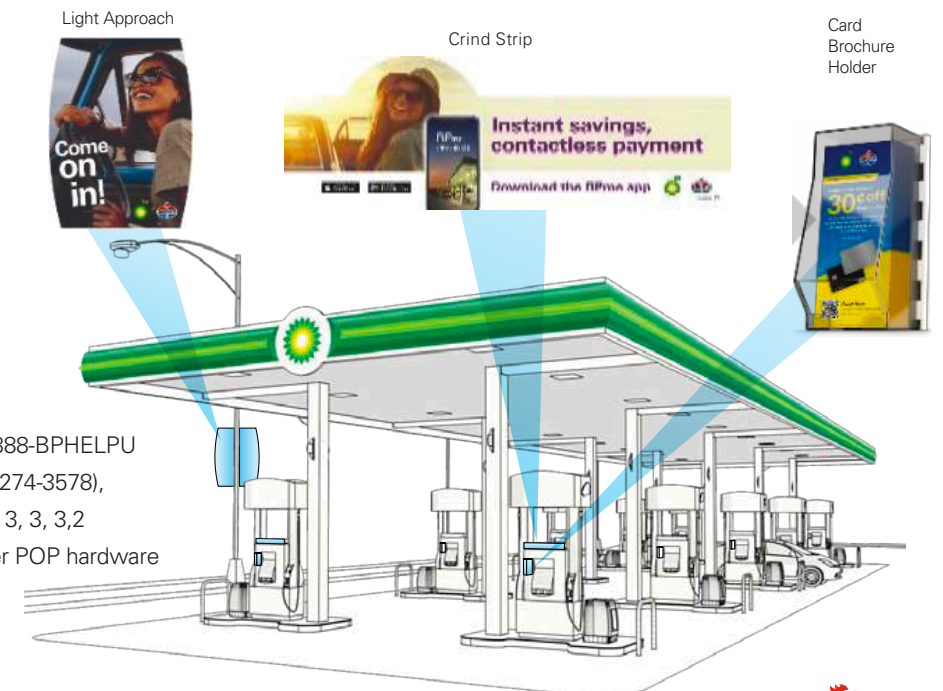

Call 1-888-BPHELPU (1-888-274-3578), option 3, 3, 3, 2 to order POP hardware

Unless prior approval has been given by the BP Image Manager: The decals shown in this rendering are the only decals approved by BP. The failure to remove existing decals, or the installation of any additional decals will be considered non-compliant with BP Brand Standards.

\*REMOVE ALL UNAPPROVED SIGNAGE FROM DISPENSERS\*

See Site Notes Page For Specific Paint Codes And Contact Info.

- Crind Hardware
- Inverted Pump Sign Hardware (NY & NJ ONLY)

- A**  Install BP Credit Card Acceptance Decal
- B**  Install BP White Dispenser Riser Panel Overlay
- C**  Panel Surrounding Electronics Must Be One Of The Following Colors And/or Any Combination Of BP White, Grey, Beige And/or Black. Blue And Red Are Not Approved Amoco Colors.

- Current electronic panel meets BP Standards
- Current electronic panel DOES NOT meet BP standards

- D**  Apply BP Branded Grade Decals
- E**  Apply Please Prepay First Decal
- F**  Install "This Is Not A BP Product" Decal
- G**  Install BP Pump Appropriate Skirt
  - Install BP Branded Skirt (as shown)  Install BP Un-Branded Skirt (as shown)

- H**  Install Spec Valance (as shown)
- I**  Apply Pump Numbers  
Decal supplied should have BP Green number with clear background)

- J**  Install Rewards Brochure Holder
- K**  Apply Regulatory Graphic Provided By BP  
(Additional graphics may be required by your state.)

- L**  Install Applicable Octane Decals
- M**  Install Correct Nozzle Covers (See Forecourt Notes Page)
- N**  Install Nozzle Surround For BP Branded Diesel
- O**  Install BP Branded Diesel Actuator Button
- P**  Apply Vertical Grade Decal For BP Branded Diesel
- Q**  Apply Handicap Decal
- R**  Apply 10% Ethanol Decal  
(As required by code)

- S**  Apply Riser Decal
- T**  Do Not Use Phone While Fueling Decal
- U**  Tap To Pay Interface

**Notes**

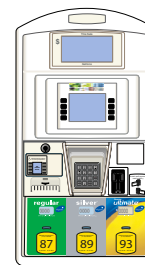

- THESE FILLER PANELS WILL NEED TO BE PURCHASED THROUGH THE DISPENSER MANUFACTURER, GILBARCO. BP PARTS WILL NOT PROVIDE THIS ON THE ESTIMATE.

- THIS IS ONLY NEEDED IF YOU ARE REIMAGING AN EXISTING DISPENSER AND THIS AREA IS AN UNAPPROVED DISPENSER COLOR (RED OR BLUE).

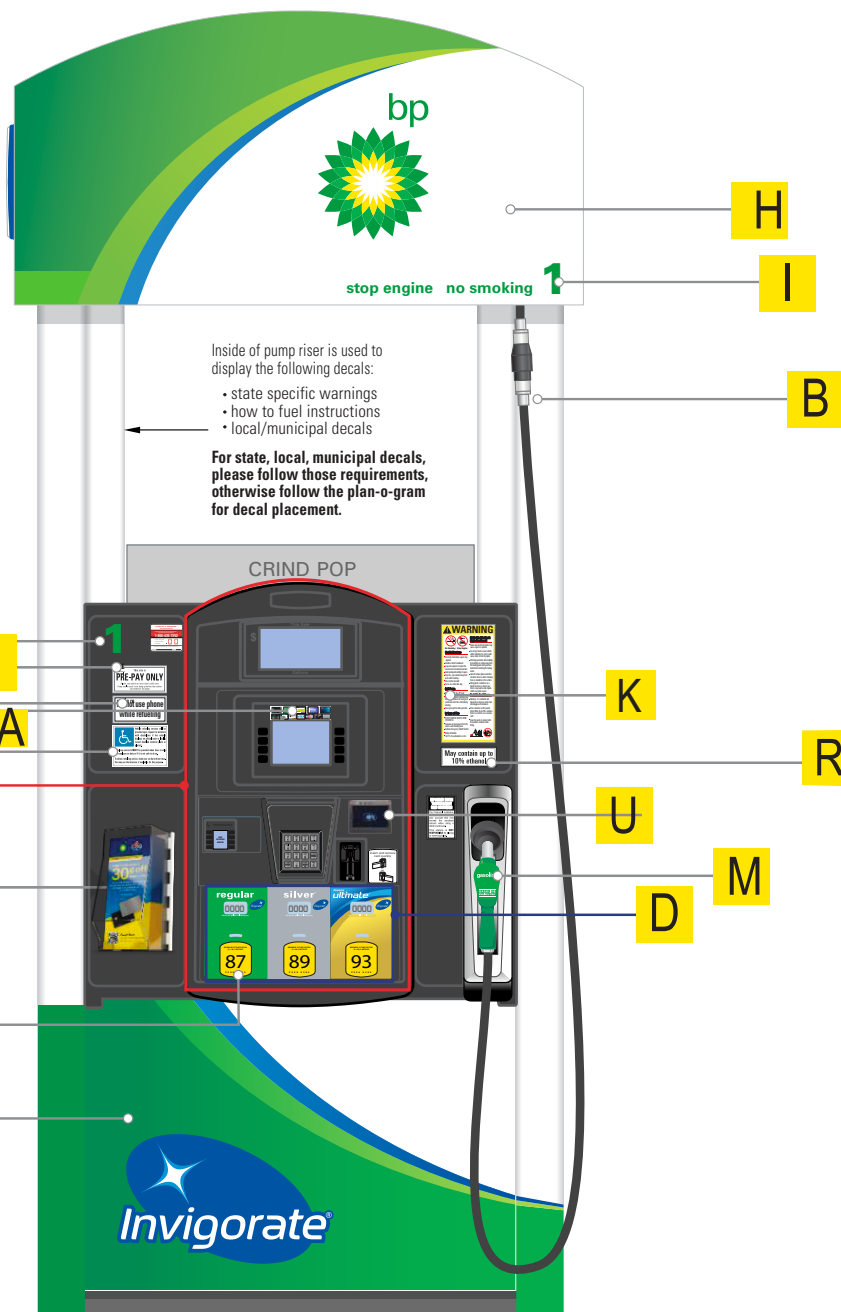

Inside of pump riser is used to display the following decals:

- state specific warnings
- how to fuel instructions
- local/municipal decals

For state, local, municipal decals, please follow those requirements, otherwise follow the plan-o-gram for decal placement.



EXISTING DISPENSER

Riser Decals Come In A Set

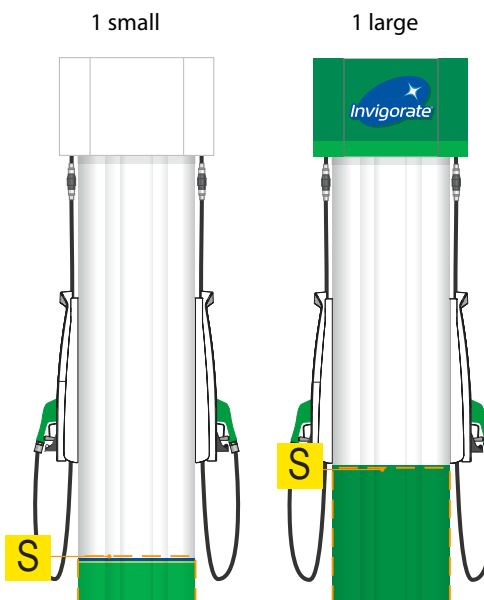

No BP image will be applied to the building.  
(this includes no Helios or the word "BP")

**Note: It Is A Requirement That The Building Have A Store Name On It.**



See Site Notes page for specific paint codes and contact info.  
**\*REMOVE ALL EXISTING SIGNAGE OFF FASCIA\***

- aa **YES**, this location is receiving a BP "Togo" \*image (Qty. 0).
  - Install: Small Illuminated Togo Sign, 52" X 28 5/8" H
  - Install: Medium Illuminated Togo Sign, 77" X 41 3/4" H
  - Install: Large Illuminated Togo Sign, 112" X 60 5/8" H

\*Note: ToGo sign to be centered over entry door and centered on the fascia above the gradient stripe.
- bb **YES**, this location is receiving a BP "Service" image. (Qty. 0).
  - Install: 5' Small Illuminated Service Sign
  - Install: 8' Large Illuminated Service Sign
- cc **Exterior Building Walls:**
  - To Be Painted BP White (C.04)  To Be Kept Neutral
- dd **Building Fascia to be**
  - Paint Fascia, BP Bright Green (C.06)  Install New ACM
  - Paint Fascia, Neutral
- ee **Is this location is receiving a Yellow Stripe?**  Yes  No
  - Install Yellow Awning Decal  Install Dimensional Yellow Awning
  - Paint Yellow Stripe
- ff **Building Door/Window WDDecal**  Yes

**WDDICAL DETAIL: NOTE TO BE DISPLAYED IN WINDOW OR DOOR**

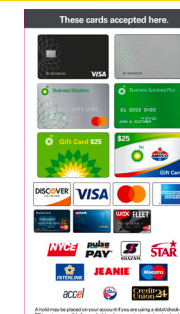

The use of **ANY** color of green is prohibited when the ToGo image is **NOT** used. If the color green is used on the building without the ToGo treatment, you will need to repaint it before financial settlement can occur. Any prior gasoline brand markings or logos need to be removed.

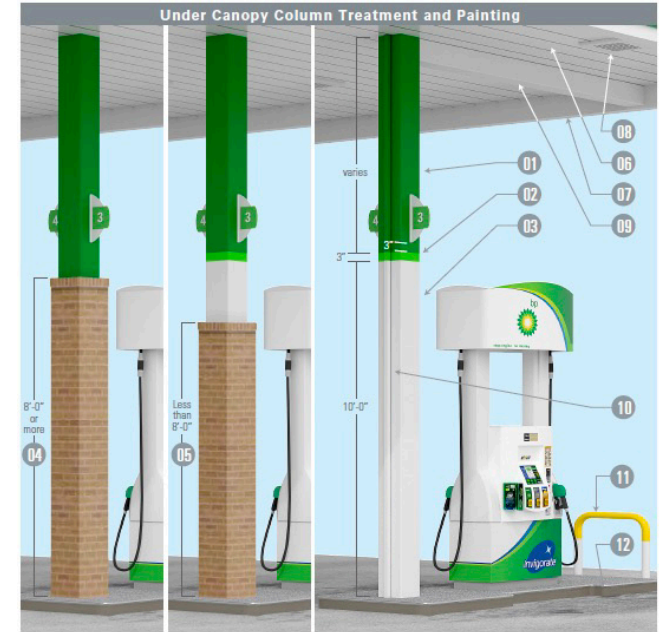
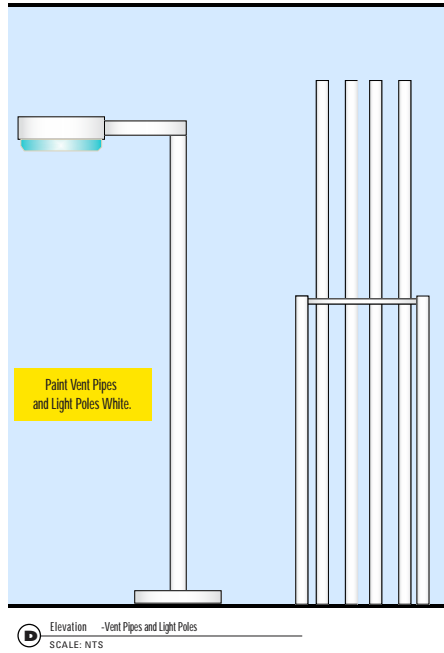
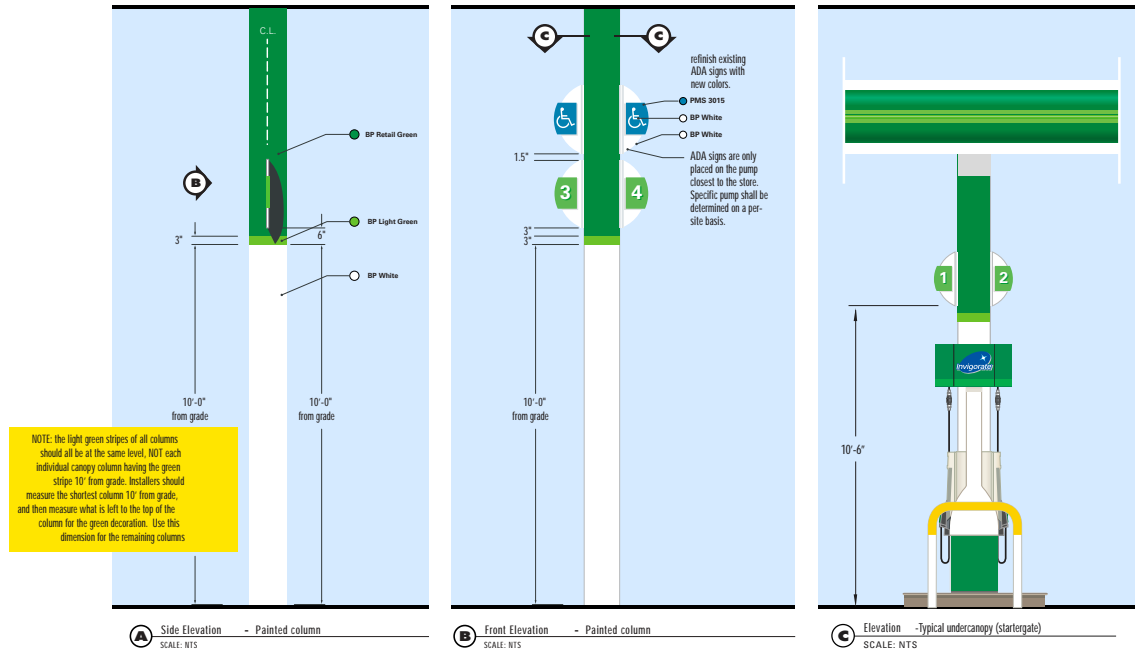

- General Notes**
- Top section of the column above 10'-3" is painted by Retail Green.
  - 3" high vinyl band between White and bp Retail Green portions of the column is bp Light Green.
  - Lower section (10 feet) of the column is painted White.
  - If there is a brick base on the column that extends 8 feet or higher up the column, then the column is painted bp Retail Green above the brick up to the canopy deck.
  - If the brick base extends less than 8 feet up the column then the standard decoration is applied above the brick base.
  - Under canopy deck for double skinned canopies is painted White. Dark Gray is allowed for diesel canopy decks.
  - Flashing and trim are painted White.
  - Lighting fixtures and bezels preferably finished White. Silver is acceptable.
  - Exposed structure is painted White.
  - Exposed conduits and plumbing / downspouts should be painted and finished to match the local column color and preferably be on the exit side of the column.
  - The top 1/3 portion of the bollard is painted to match bp Yellow. For non-integrated bollards, the lower 2/3 portion is painted White.
  - Dispenser island painted by Warm Gray.

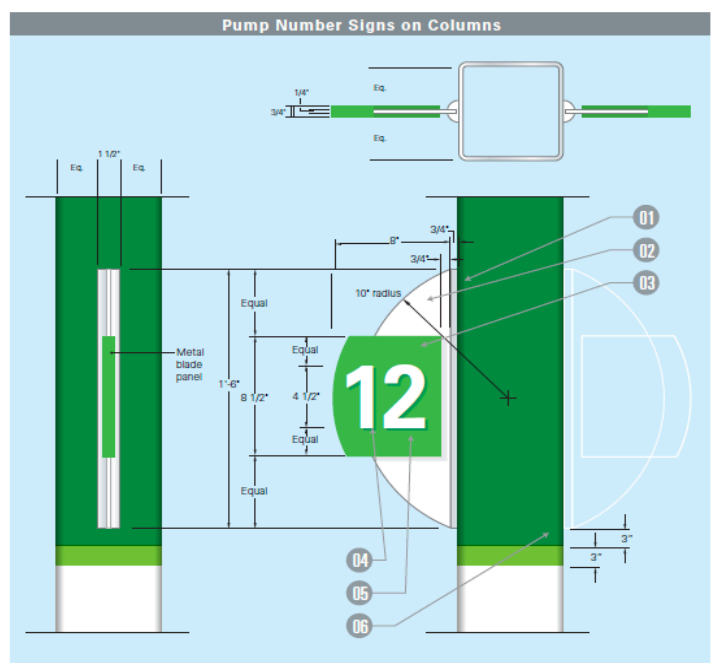
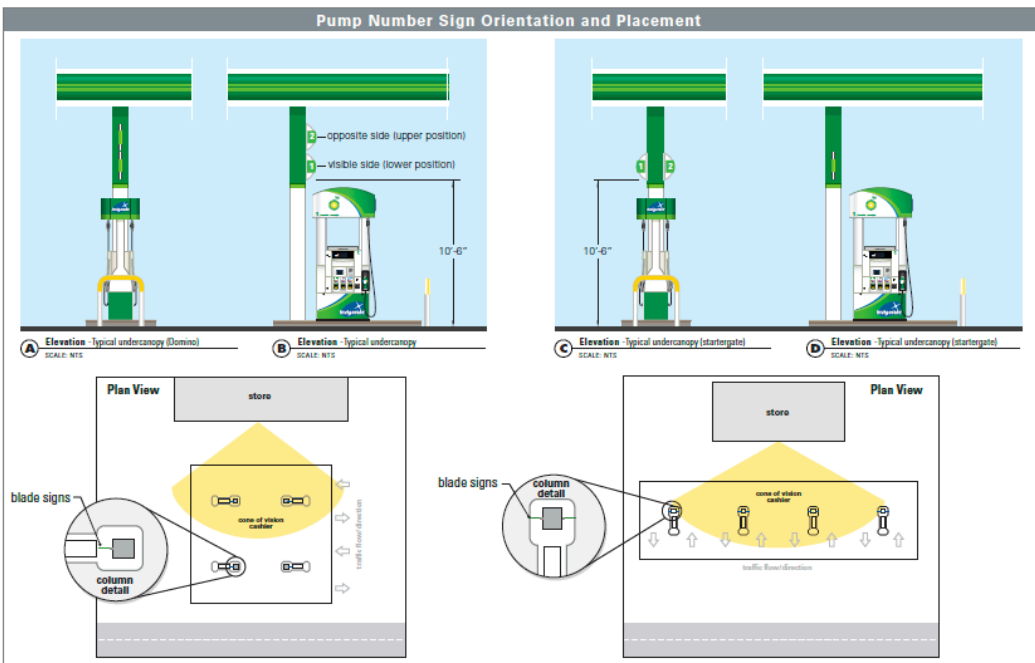

- General Notes**
- The signs that tell the customers the number of the dispensers, also known as "Blade Signs," are constructed of aluminum and comprised of the following parts:
- The bent or extruded aluminum base is painted White.
  - The curved aluminum blade panel that fits into the bent or extruded aluminum base is also painted White.
  - The 3/4" thick (bent to shape) blade panel that forms the backdrop for the numerals is painted bp Light Green.
  - 4 1/2" White numeral decals are centered both vertically and horizontally on the bp Light Green blade panel.
  - The numeral drop shadow is bp Green.
  - Pump number signs are installed 3" above the 3" bp Light Green vinyl stripe on the column.

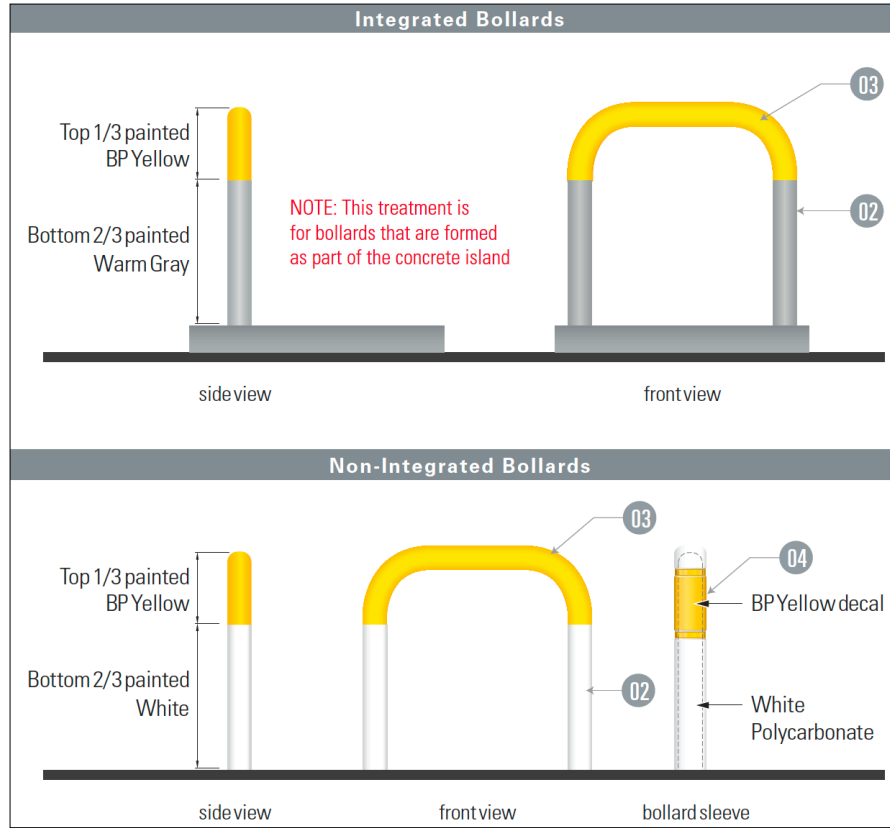

Curbs with integrated bollard are to be painted BP Warm Grey.

Top 1/3 of integrated bollard to be painted BP Yellow.

**EXTERIOR PAINT SPECIFICATIONS**

	<b>01 BP Pearl</b> - Glidden Professional, Order #A0083, Spec #38YY 72/117, "Indian Legend" - Sherwin Williams, SW6119, "Antique White" - Benjamin Moore, OC-8, "Elephant Tusk" - P28 DTM (Gallon) - Anchor Paint, BP Pearl - CC3065 (Acrylic), CC3112 (Oil)
	<b>02 BP Warm Gray</b> - Glidden Professional, Order #A1860, Spec #40YY 25/074, "Grey Mountain" - Sherwin Williams, SW7053, "Adaptive Shade" - Benjamin Moore, 2137-40, "Desert Twilight" - P28 DTM (Gallon) - Anchor Paint, BP Warm Gray - CC3068 (Acrylic), CC3115 (Oil)
	<b>03 BP Yellow (Paint)</b> - Glidden Professional, Order #A0775, Spec #37YY 61/867, "Omega Yellow" - Sherwin Williams, SW6903, "Cheerful" - Benjamin Moore, 2022-10, "Yellow" - P28 DTM (Gallon) - Anchor Paint, BP Yellow - CC3066 (Acrylic), CC3113 (Oil) BP Yellow (ACM) - Reynobond, "Program Yellow"
	<b>04 White (Canopy Deck, Canopy Columns)</b> - Glidden Professional, Order #A0128, Spec #50GY 83/010, "White Wing" - Sherwin Williams, SW7006, "Extra White" - Benjamin Moore, OC-67, "Ice Mist" - P28 DTM (Gallon) - Anchor Paint, BP White - 4900 (Acrylic), 900 (Oil)
	<b>05 BP Dark Pearl</b> - Glidden Professional, Order #A0767, Spec #30YY 52/207, "Desert Valley" - Sherwin Williams, SW6121, "Whole Wheat" - Benjamin Moore, HC-24, "Pittsfield Buff" - P28 DTM (Gallon)
	<b>06 BP Bright Green (to go fascia paint)</b> - Benjamin Moore, 2030-10, "Lizard Green" - Anchor Paint, BP White - CC3107 (Acrylic), CC3116 (Oil) BP Bright Green (to go ACM) - Duragloss 3000, CMR# 071013-D, 497G11281 H/G SR Green
	<b>09 BP Retail Green</b> - Glidden Professional, Custom Color "BP Retail Green" - Sherwin Williams, Hydrogloss B65GW180, Custom Color - Benjamin Moore, BP Retail Green - PMS 348c, Custom Color - Anchor Paint, BP Retail Green - CC3067 (Acrylic), CC3114 (Oil)
	<b>10 ADA/Handicap Blue~</b> - Glidden Professional, "Handicap Blue", 25524 traffic paint - Sherwin Williams, TM2133, "Setfast Blue", Setfast marking latex - Benjamin Moore, P58-30, "Handicap Blue", Safety/Zone marking latex

**ADA BLUE**

-Handicap Blue paint is used for pavement striping and marking on site (as required).

**BP EXTERIOR SIGNAGE**

	<b>BP Yellow - PMS 109</b>
	<b>BP Super Bright Green (to go) - PMS 382</b>
	<b>BP Extra Light Green (to go) - PMS 376</b>
	<b>BP Light Green - PMS 368</b>
	<b>BP Bright Green (to go) - PMS 361</b>
	<b>BP Green - PMS 355</b>
	<b>BP Retail Green - PMS 348</b>
	<b>BP Dark Green (to go) - PMS 356</b>

For all paint inquiries, contact:

<b>Benjamin Moore</b> 855-724-6802 www.benjaminmoore.com	<b>Glidden Professional</b> 888-615-8169 www.gliddenprofessional.com
<b>Sherwin Williams</b> 800-474-3794 www.sherwin-williams.com	<b>Anchor Paint</b> 405-831-9446 www.anchorpaint.com

**Printing Concepts:**

1. Open your PDF file through Adobe Acrobat and click the "File" tab > "Print..." This will cause a popup to appear on your screen. Locate the "A" button to get to the next step.

Select Print as Image

Clicking the 'Advanced' button will cause another popup to appear on your screen, this time you need to click the "Print as Image" button. With this, you are done! Just click "OK" and "Print."

All existing trash containers must be removed and replaced with BP approved containers. These containers must be BP approved colors.

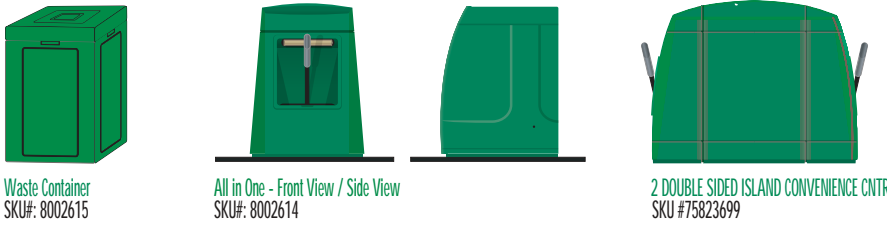

This is an original concept drawing created by Big Red Rooster Flow, LLC. It is submitted for use in connection with the project being planned for you by BRRFlow. All or any part of this design (except registered trademarks) remains the property of BRRFlow. This drawing is not to scale. For all questions regarding the scope of the project, please contact Steve Garrity 847.232.7621 or The Brand Image Adviser, Debbie Petruskas 630.544.4425 / Larry Rollins 708.495.5814

