

ANN ARBOR HISTORIC DISTRICT COMMISSION

Staff Report

ADDRESS: 113 W Washington Street, Application Number HDC21-337

DISTRICT: Main Street Historic District

REPORT DATE: January 13, 2022

REPORT PREPARED BY: Jill Thacher, Historic Preservation Coordinator

REVIEW COMMITTEE DATE: January 10, 2022

OWNER

APPLICANT

Name: 113 West Washington LLC
Address: 113 West Washington
Ann Arbor, MI 48104
Phone: (734) 657-2096

Ann Arbor Art Center
117 W Liberty Street
Ann Arbor, MI 48104
(734) 994-8004

BACKGROUND: The site is a public alley that runs between the east side of 113 East Washington and the rear of 200 South Main Street.

LOCATION: The site is located on the north side of West Washington, between South Main Street and South Ashley Street.

APPLICATION: The applicant seeks HDC approval to install nine banners that span the alley as part of a one-year public art installation.

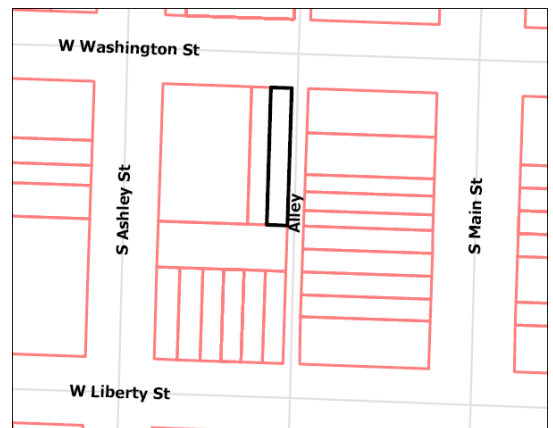

APPLICABLE REGULATIONS:

From the Secretary of the Interior’s Standards for Rehabilitation:

(2) The historic character of a property will be retained and preserved. The removal of distinctive materials or alteration of features, spaces, and spatial relationships that characterize a property will be avoided.

(10) New additions and adjacent or related new construction will be undertaken in such a manner that, if removed in the future, the essential form and integrity of the historic property will be unimpaired.

From the Secretary of the Interior's Guidelines for Rehabilitating Historic Buildings: Building Site

Recommended: Designing new exterior additions to historic buildings or adjacent new construction which is compatible with the historic character of the site and which preserve the historic relationship between a building or buildings, landscape features, and open space.

Not Recommended: Introducing new construction onto the building site which is visually incompatible in terms of size, scale, design, materials, color and texture or which destroys historic relationships on the site.

Masonry

Recommended: Identifying, retaining, and preserving masonry features that are important in defining the overall historic character of the building such as walls, brackets, railings, cornices, window architraves, door pediments, steps, and columns; and details such as tooling and bonding patterns, coatings, and color.

Not Recommended: Removing or radically changing masonry features which are important in defining the overall historic character of the building so that, as a result, the character is diminished.

From the Ann Arbor Historic District Design Guidelines:

Signs

Appropriate: Attaching signage through masonry joints, not masonry units, or through materials that can be easily repaired, such as wood, when the signage is removed.

STAFF FINDINGS:

1. This application was postponed at the request of the applicant from the December, 2021 HDC agenda in order to address installation issues.
2. Signatures were provided from both property owners and the City of Ann Arbor, which owns the alley.
3. This application is for a public art installation in the alley between 113 West Washington and 200 South Main Street. Nine fabric banners are hung between the alley walls on a metal rod. The nine metal rods attach to a continuous ledger angle mounted to the wall with concrete anchors in mortar joints measuring 3/8" or more. The bottoms of the banners are mounted 15' above ground (to provide clearance for vehicles), and the banners are 4'3 7/8" tall. (Conceptual color renderings are included in the application – please note that these are from a public art competition and are not to the scale proposed in this application.)
4. There is no mention of removing the concrete anchors or repairing holes they've caused

in the mortar after they're removed, so staff has included this language in the suggested motion. The mortar used to repair the joints must be an appropriate match for the building as described in National Park Service Preservation Brief #2, *Repointing Mortar Joints in Historic Masonry Buildings* (<https://www.nps.gov/tps/how-to-preserve/briefs/2-repoint-mortar-joints.htm>).

5. Staff believes the work as conditioned is sensitive to the historic building and meets the standards and guidelines used by the Historic District Commission.

POSSIBLE MOTION: (Note that the motion supports staff findings and is only a suggestion. The Review Committee, consisting of staff and at least two Commissioners, will meet with the applicant on site and then make a recommendation at the meeting.)

I move that the Commission issue a certificate of appropriateness for the application in the alley between 113 West Washington Street and 200 South Main, both contributing properties in the Main Street Historic District, to install nine banner rods on brackets mounted on a continuous ledger as described in mortar joints, on the following conditions: that all hardware is removed and the mortar joints repaired with an appropriate mortar match when the exhibit ends in a year. As conditioned, the work is compatible in exterior design, arrangement, texture, material and relationship to the rest of the building and the surrounding area and meets *The Secretary of the Interior's Standards for Rehabilitation and Guidelines for Rehabilitating Historic Buildings*, in particular standards 2 and 10, and the guidelines for building sites and masonry, and the *Ann Arbor Historic District Design Guidelines*.

ATTACHMENTS: application, drawings, masonry notes, project information

113 W Washington and 200 South Main, November 2020 (courtesy Google Street View)







HISTORIC DISTRICT COMMISSION

PLANNING AND DEVELOPMENT SERVICES

City Hall: 301 E. Huron St. Ann Arbor, MI 48104-6120

Mailing: P.O. Box 8647, Ann Arbor, MI 48107-8647

Phone: 734.794.6265 ext. 42608

ithacher@a2gov.org

Fax: 734.994.8460

APPLICATION MUST BE FILLED OUT COMPLETELY

OFFICE USE ONLY	
Permit Number	HDC# _____
	BLDG# _____
DATE STAMP	

PROPERTY LOCATION/OWNER INFORMATION

NAME OF PROPERTY OWNER 113 West Washington, LLC		HISTORIC DISTRICT Main Street	
PROPERTY ADDRESS 113 West Washington St.			CITY ANN ARBOR
ZIPCODE 48104	DAYTIME PHONE NUMBER (734-657)-2096	EMAIL ADDRESS info@ptpmgt.com	
PROPERTY OWNER'S ADDRESS (IF DIFFERENT FROM ABOVE) P. O. Box 8383		CITY Ann Arbor	STATE, ZIP 48107

PROPERTY OWNER'S SIGNATURE

SIGN HERE	PRINT NAME → Faramarz Farahanchi	DATE → 11/16/2021
------------------	-----------------------------------------	--------------------------

APPLICANT INFORMATION

NAME OF APPLICANT (IF DIFFERENT FROM ABOVE) Ann Arbor Art Center			
ADDRESS OF APPLICANT 117 W Liberty Street			CITY Ann Arbor
STATE Michigan	ZIPCODE 48104	PHONE / CELL # (734-994)-8004	FAX No ()
EMAIL ADDRESS mklopf@annarborartcenter.org			

APPLICANT'S SIGNATURE (if different from Property Owner)

SIGN HERE	PRINT NAME → MARIE KLOPF	DATE → 11/16/2021
------------------	---------------------------------	--------------------------

BUILDING USE – CHECK ALL THAT APPLY

<input type="checkbox"/> SINGLE FAMILY	<input type="checkbox"/> DUPLEX	<input type="checkbox"/> RENTAL	<input type="checkbox"/> MULTIPLE FAMILY	<input checked="" type="checkbox"/> COMMERCIAL	<input type="checkbox"/> INSTITUTIONAL
----------------------------------------	---------------------------------	---------------------------------	------------------------------------------	------------------------------------------------	----------------------------------------

PROPOSED WORK

Describe in detail each proposed exterior alteration, improvement and/or repair (use additional paper, if necessary).

See attached

DESCRIBE CONDITIONS THAT JUSTIFY THE PROPOSED CHANGES:

See attached

For Further Assistance With Required Attachments, please visit www.a2gov.org/hdc



HISTORIC DISTRICT COMMISSION APPLICATION

FEE CHART

DESCRIPTION	
STAFF REVIEW FEES	FEE
Application for Staff Approval	\$35.00
Work started without approvals	Additional \$50.00
HISTORIC DISTRICT COMMISSION FEES	
All other proposed work not listed below	\$100.00
Work started without approvals	Additional \$250.00
RESIDENTIAL – Single and 2-story Structure	
Addition: single story	\$300.00
Addition: taller than single story	\$550.00
New Structure - Accessory	\$100.00
New Structure – Principal	\$850.00
Replacement of single and 2-family window(s)	\$100 + \$25/window
COMMERCIAL – includes multi-family (3 or more unit) structures	
Additions	\$700.00
Replacement of multi-family and commercial window (s)	\$100 + \$50/window
Replacement of commercial storefront	\$250.00
DEMOLITION and RELOCATION	
Demolition of a contributing structure	\$1000.0
Demolition of a non-contributing structure	\$250.00
Relocation of a contributing structure	\$750.00
Relocation of a non-contributing structure	\$250.00

FOR COMMISSION REVIEWS:

- Application withdrawals made before public notice is published will qualify for a 50% refund of the application fee.
- Application withdrawals made after public notice is sent but before the public hearing will qualify for a 25% refund of the application fee.

INSTRUCTIONS FOR SUBMITTING APPLICATIONS

All HDC applications must be signed by the property owner and the applicant, if different, with the exception of staff approvals, which may be signed by only the applicant.

All completed HDC applications and their attachments may be submitted to Planning and Development Services by mail, in person (paper or digital), faxed, or via email to building@a2gov.org.

We accept CASH, CHECK, and all major credit cards. Checks should be made payable to “City of Ann Arbor”

HDC applications that are incomplete or not submitted with the required documentation or payment will not be processed or approved.

APPLICATION EXPIRATION

HDC applications expire three (3) years after the date of approval.

OFFICE USE ONLY

Date of Hearing:		
Action	<input type="checkbox"/> HDC COA	<input type="checkbox"/> HDC Denial
	<input type="checkbox"/> HDC NTP	<input type="checkbox"/> Staff COA
Staff Signature		
Comments		
Fee:	\$ _____	
Payment Type	<input type="checkbox"/> Check: # _____ <input type="checkbox"/> Cash <input type="checkbox"/> Credit Card	



HISTORIC DISTRICT COMMISSION

PLANNING AND DEVELOPMENT SERVICES

City Hall: 301 E. Huron St. Ann Arbor, MI 48104-6120
 Mailing: P.O. Box 8647, Ann Arbor, MI 48107-8647
 Phone: 734.794.6265 ext. 42608 ithacher@a2gov.org
 Fax: 734.994.8460

OFFICE USE ONLY	
Permit Number	HDC# _____
	BLDG# _____
DATE STAMP	

APPLICATION MUST BE FILLED OUT COMPLETELY

PROPERTY LOCATION/OWNER INFORMATION

NAME OF PROPERTY OWNER Harvey Shapiro		HISTORIC DISTRICT Main Street	
PROPERTY ADDRESS 200 S. Main Street Ann Arbor MI, 48104			CITY ANN ARBOR
ZIPCODE 48104	DAYTIME PHONE NUMBER (48104)	EMAIL ADDRESS 206smain@gmail.com	
PROPERTY OWNER'S ADDRESS (IF DIFFERENT FROM ABOVE) 6414 Countryshire Lane		CITY West Bloomfield	STATE, ZIP Mi, 48322

PROPERTY OWNER'S SIGNATURE

SIGN HERE	DocuSigned by: 470C3217D853412...	PRINT NAME → Ben Shapiro	DATE → 11/18/2021
------------------	------------------------------------------	---------------------------------	--------------------------

APPLICANT INFORMATION

NAME OF APPLICANT (IF DIFFERENT FROM ABOVE) Ann Arbor Art Center			
ADDRESS OF APPLICANT 117 W Liberty Street			CITY Ann Arbor
STATE Michigan	ZIPCODE 48104	PHONE / CELL # (734-994-8004	FAX No ()
EMAIL ADDRESS mklopf@annarborartcenter.org			

APPLICANT'S SIGNATURE (if different from Property Owner)

SIGN HERE	DocuSigned by: 89B68D527D7B4B4...	PRINT NAME → MARIE KLOPF	DATE → 11/19/2021
------------------	------------------------------------------	---------------------------------	--------------------------

BUILDING USE – CHECK ALL THAT APPLY

<input type="checkbox"/> SINGLE FAMILY	<input type="checkbox"/> DUPLEX	<input type="checkbox"/> RENTAL	<input type="checkbox"/> MULTIPLE FAMILY	<input checked="" type="checkbox"/> COMMERCIAL	<input type="checkbox"/> INSTITUTIONAL
----------------------------------------	---------------------------------	---------------------------------	------------------------------------------	------------------------------------------------	----------------------------------------

PROPOSED WORK

Describe in detail each proposed exterior alteration, improvement and/or repair (use additional paper, if necessary).

See attached

DESCRIBE CONDITIONS THAT JUSTIFY THE PROPOSED CHANGES:

See attached

For Further Assistance With Required Attachments, please visit www.a2gov.org/hdc



HISTORIC DISTRICT COMMISSION APPLICATION

FEE CHART

DESCRIPTION	
STAFF REVIEW FEES	FEE
Application for Staff Approval	\$35.00
Work started without approvals	Additional \$50.00
HISTORIC DISTRICT COMMISSION FEES	
All other proposed work not listed below	\$100.00
Work started without approvals	Additional \$250.00
RESIDENTIAL – Single and 2-story Structure	
Addition: single story	\$300.00
Addition: taller than single story	\$550.00
New Structure - Accessory	\$100.00
New Structure – Principal	\$850.00
Replacement of single and 2-family window(s)	\$100 + \$25/window
COMMERCIAL – includes multi-family (3 or more unit) structures	
Additions	\$700.00
Replacement of multi-family and commercial window (s)	\$100 + \$50/window
Replacement of commercial storefront	\$250.00
DEMOLITION and RELOCATION	
Demolition of a contributing structure	\$1000.0
Demolition of a non-contributing structure	\$250.00
Relocation of a contributing structure	\$750.00
Relocation of a non-contributing structure	\$250.00

FOR COMMISSION REVIEWS:

- Application withdrawals made before public notice is published will qualify for a 50% refund of the application fee.
- Application withdrawals made after public notice is sent but before the public hearing will qualify for a 25% refund of the application fee.

INSTRUCTIONS FOR SUBMITTING APPLICATIONS

All HDC applications must be signed by the property owner and the applicant, if different, with the exception of staff approvals, which may be signed by only the applicant.

All completed HDC applications and their attachments may be submitted to Planning and Development Services by mail, in person (paper or digital), faxed, or via email to building@a2gov.org.

We accept CASH, CHECK, and all major credit cards. Checks should be made payable to “City of Ann Arbor”

HDC applications that are incomplete or not submitted with the required documentation or payment will not be processed or approved.

APPLICATION EXPIRATION

HDC applications expire three (3) years after the date of approval.

OFFICE USE ONLY

Date of Hearing:		
Action	<input type="checkbox"/> HDC COA	<input type="checkbox"/> HDC Denial
	<input type="checkbox"/> HDC NTP	<input type="checkbox"/> Staff COA
Staff Signature		
Comments		
Fee:	\$ _____	
Payment Type	<input type="checkbox"/> Check: # _____ <input type="checkbox"/> Cash <input type="checkbox"/> Credit Card	



Jefferson Lettieri Office

1105 Taughannock Blvd.
Ithaca, NY 14850
T +1 317 370 4336 (Michael Jefferson)
T +1 917 647 1491 (Suzanne Lettieri)

**Ann Arbor Art Center (A2AC)
The Alleyway Project
Ann Arbor, MI**

Key Plan and Legend

Alley located along W Washington St
between 113 W Washington St
and 200 South Main St

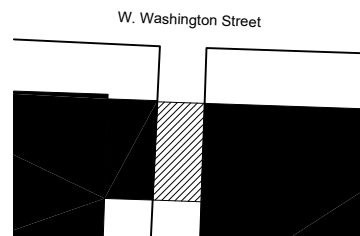

Notes

Above ground clearance of 15' required
by the city

Not for construction

Revisions

Roof Plan

PROJ. NO.:	A2AC	DATE:	11/14/2021
DWG. BY:	MJ	PAGE:	1XX of 1XX
© Jefferson Lettieri Office 2021		SCALE:	1/4"=1'

A101

113 W Washington St

200 South Main St

Unistrut
aluminum
channel, 1-5/8"
x 1-5/8", 12
Gage

40'-0"

EQ

EQ

EQ

EQ

EQ

EQ

EQ

EQ

A300

A301

A300

A301

NOT FOR CONSTRUCTION





Jefferson Lettieri Office

1105 Taughannock Blvd.
Ithaca, NY 14850
T +1 317 370 4336 (Michael Jefferson)
T +1 917 647 1491 (Suzanne Lettieri)

Ann Arbor Art Center (A2AC)
The Alleyway Project
Ann Arbor, MI

Key Plan and Legend

Alley located along W Washington St
between 113 W Washington St
and 200 South Main St

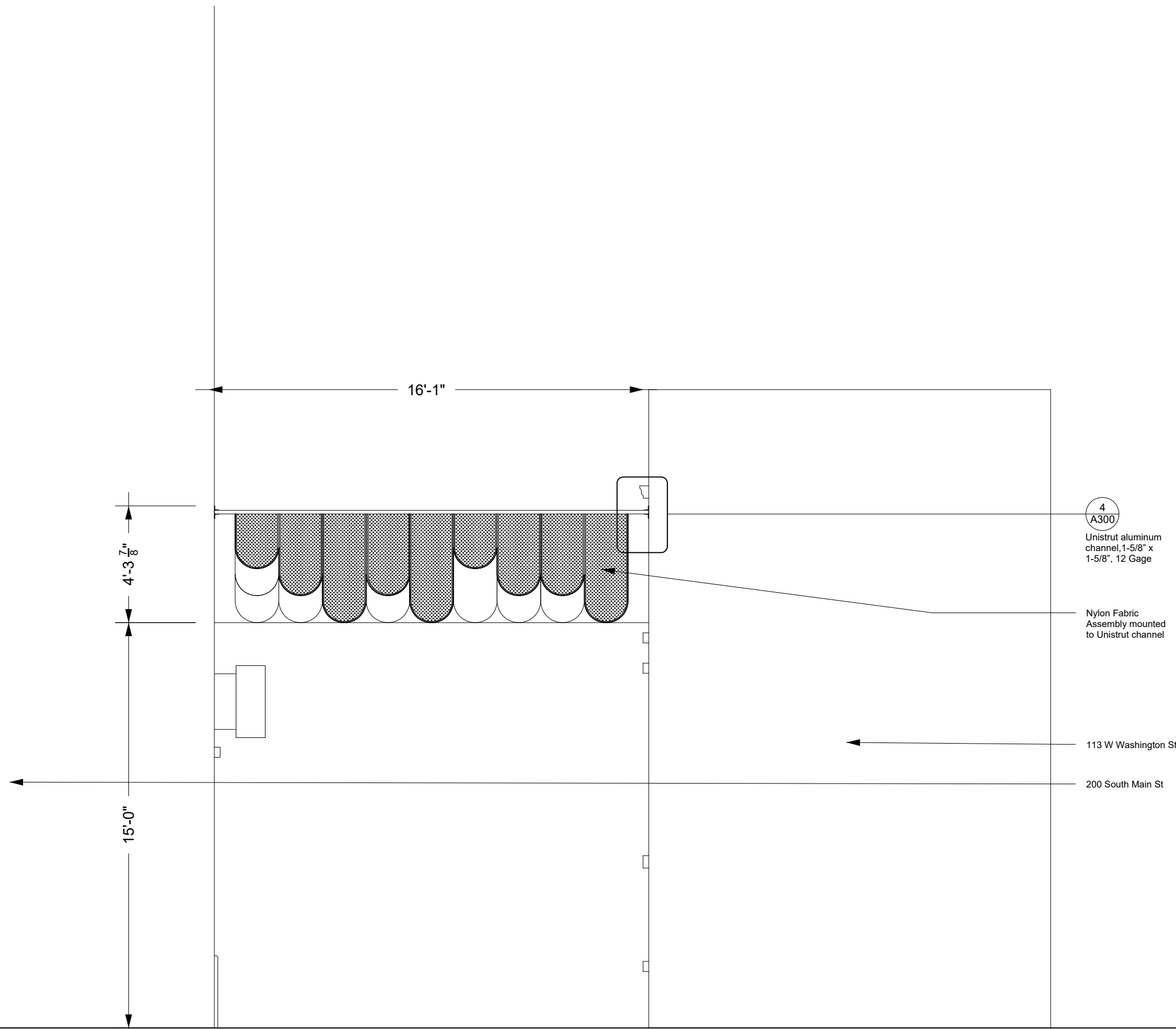
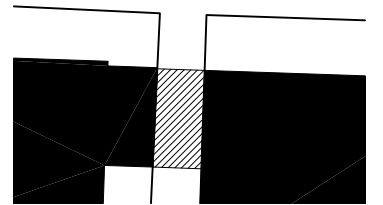

4
A300
Unistrut aluminum
channel, 1-5/8" x
1-5/8", 12 Gage

Nylon Fabric
Assembly mounted
to Unistrut channel

113 W Washington St

200 South Main St

Notes

Above ground clearance of 15' required
by the city

Not for construction

Revisions

South Elevation

PROJ. NO.:	A2AC	DATE:	11/14/2021
DWG. BY:	MJ	PAGE:	1XX of 1XX
© Jefferson Lettieri Office 2021		SCALE: 1/4"=1'	

NOT FOR CONSTRUCTION

A300



Jefferson Lettieri Office

1105 Taughannock Blvd.
Ithaca, NY 14850
T +1 317 370 4336 (Michael Jefferson)
T +1 917 647 1491 (Suzanne Lettieri)

Ann Arbor Art Center (A2AC)
The Alleyway Project
Ann Arbor, MI

Key Plan and Legend

Alley located along W Washington St
between 113 W Washington St
and 200 South Main St

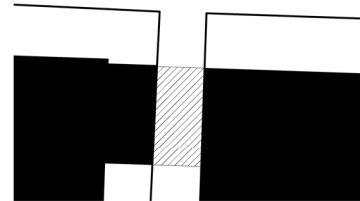

Notes

Above ground clearance of 15' required
by the city

Not for construction

Elevation of 113 W Washington St
visible

Revisions

1/6/2022	

Section

PROJ. NO.:	A2AC	DATE:	1/6/2022
DWG. BY:	MJ	PAGE:	1XX of 1XX
© Jefferson Lettieri Office 2021		SCALE: 1/4"=1'	

A300

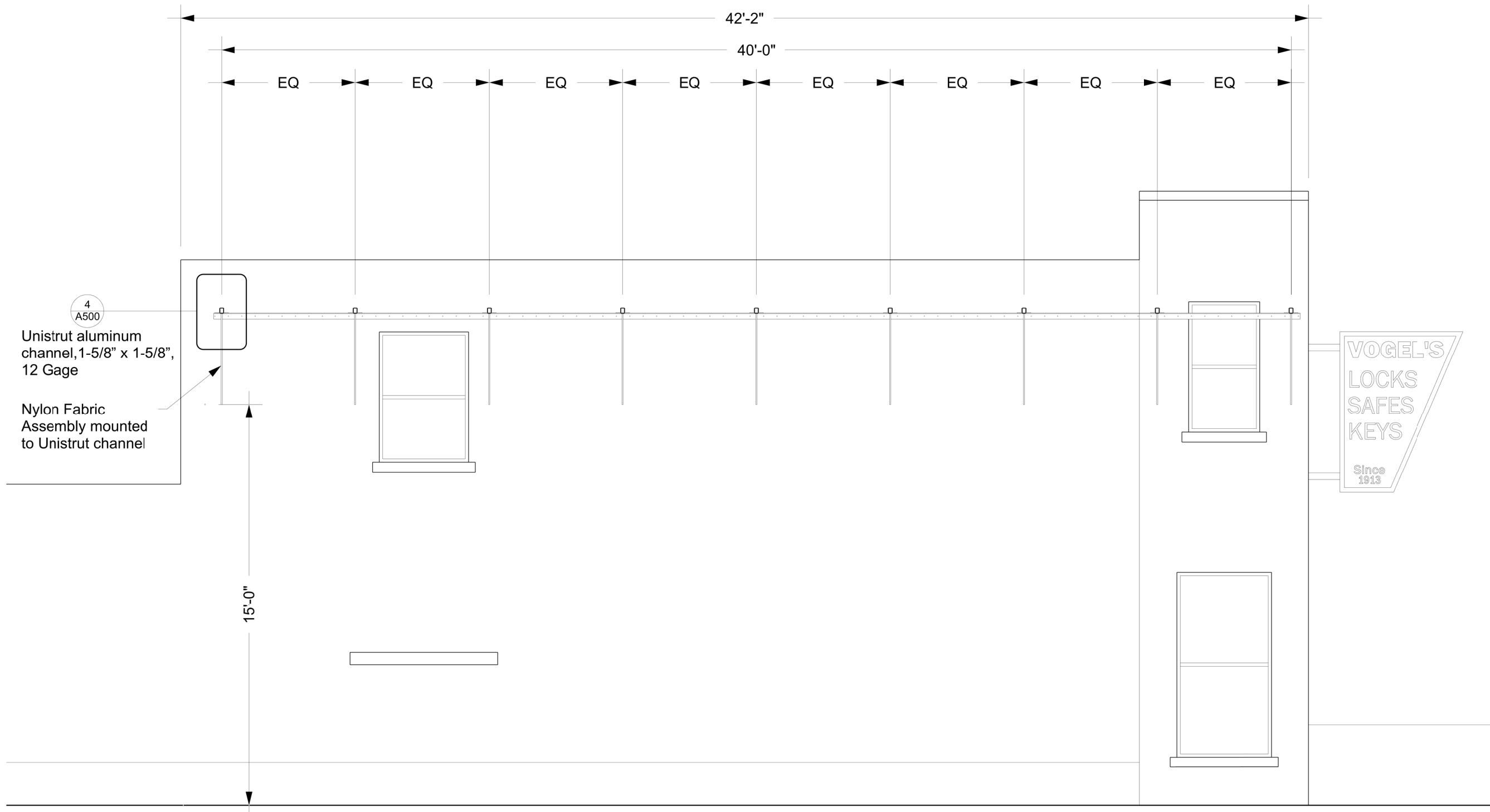

NOT FOR CONSTRUCTION

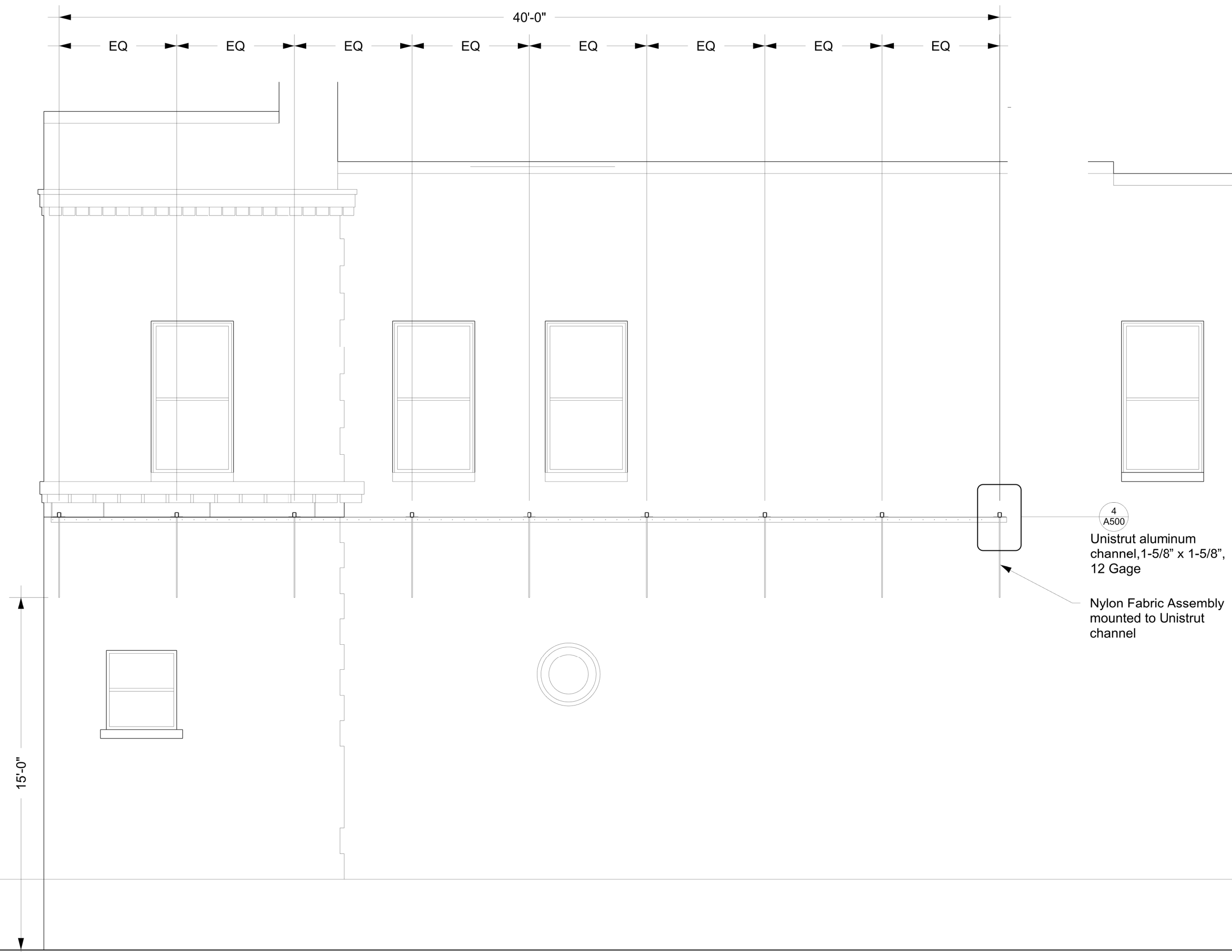

Jefferson Letteri Office

1105 Taughanock Blvd.
Ithaca, NY 14850
T +1 317 370 4336 (Michael Jefferson)
T +1 917 647 1491 (Suzanne Letteri)

**Ann Arbor Art Center (A2AC)
The Alleyway Project
Ann Arbor, MI**

Key Plan and Legend

Alley located along W Washington St
between 113 W Washington St
and 200 South Main St

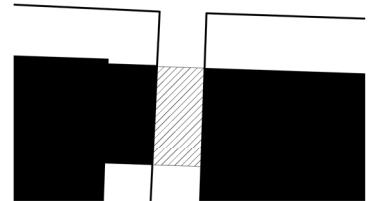

Notes

- Above ground clearance of 15' required by the city
- Not for construction
- Elevation of 200 South Main St visible

Revisions

1/6/2022	

Section

PROJ. NO.: A2AC	DATE: 1/6/2022
DWG. BY: MJ	PAGE: 1XX of 1XX
© Jefferson Letteri Office 2021	SCALE: 1/4"=1'

A301

NOT FOR CONSTRUCTION

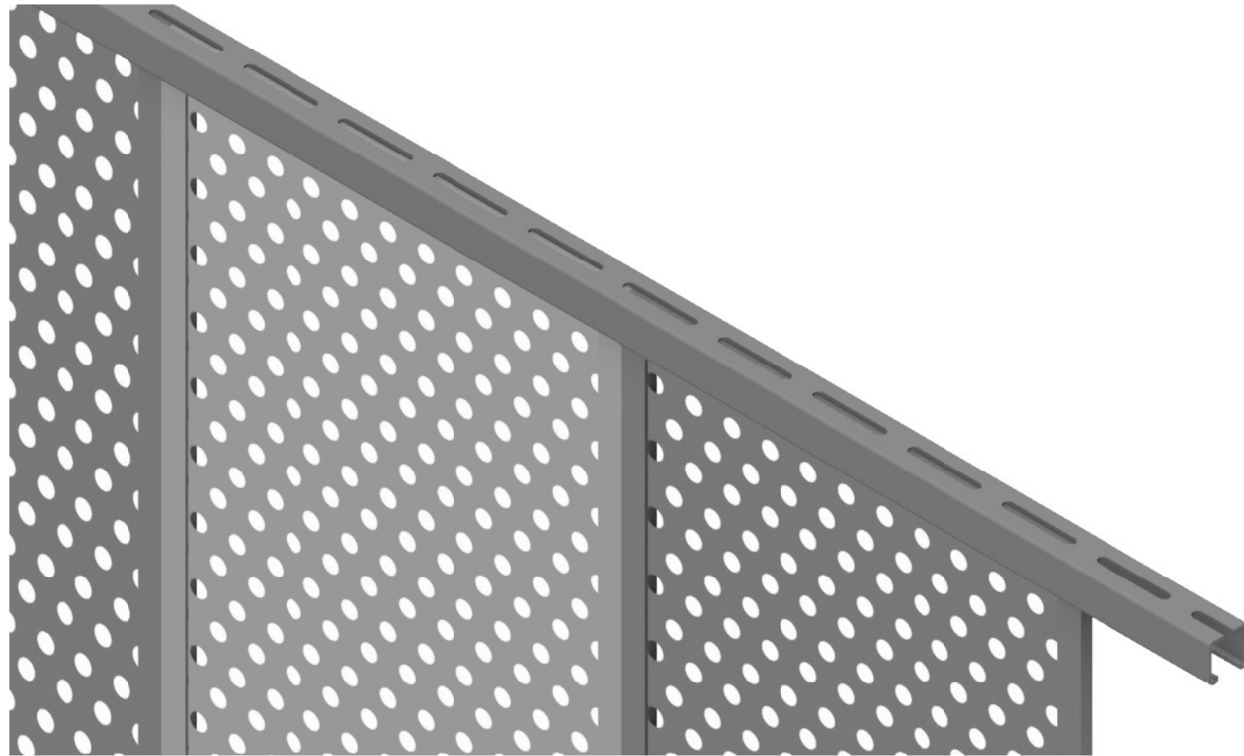

1 Detail Axonometric

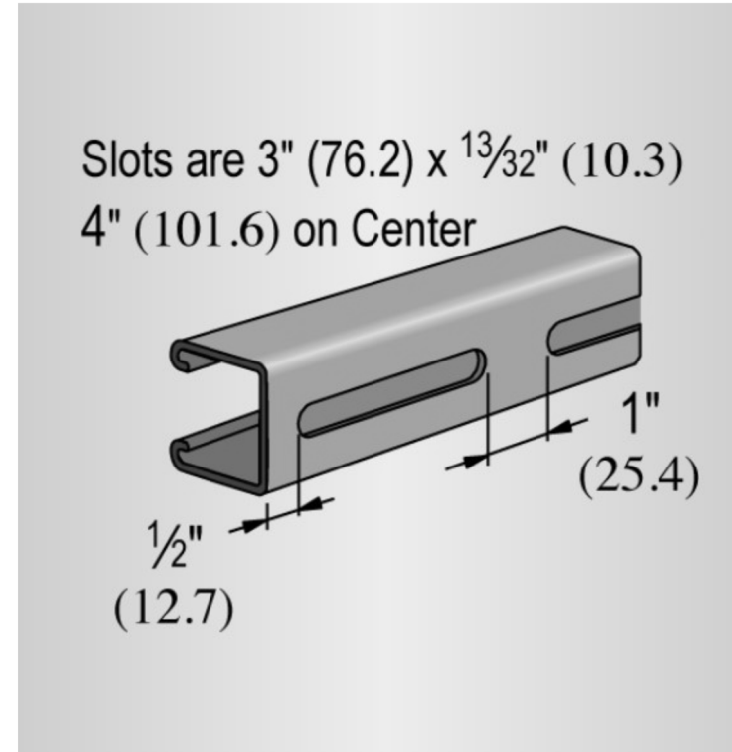

2 Structural Member Axonometric (to be confirmed)

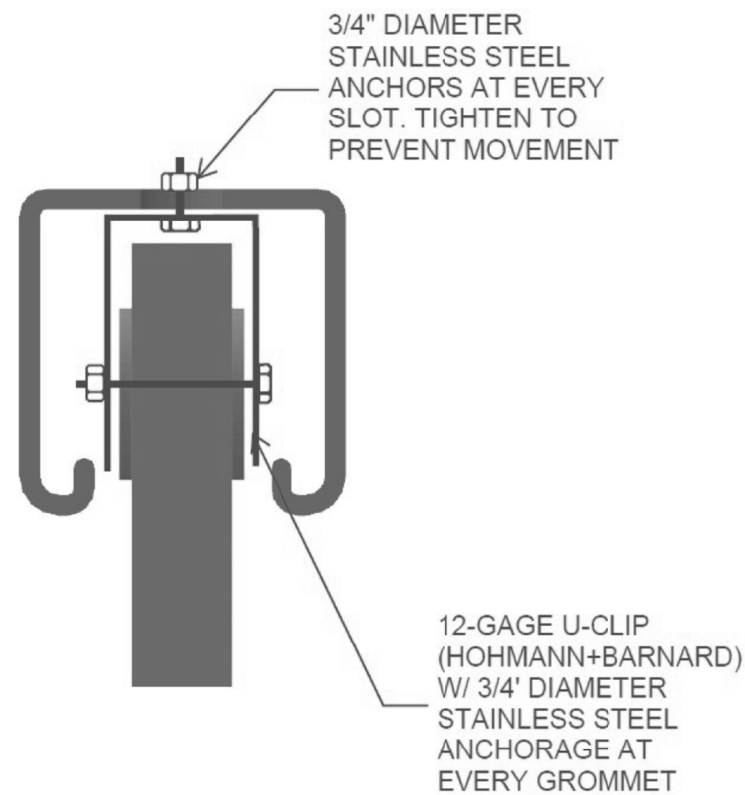

3 Fabric Panel Connection to Structure

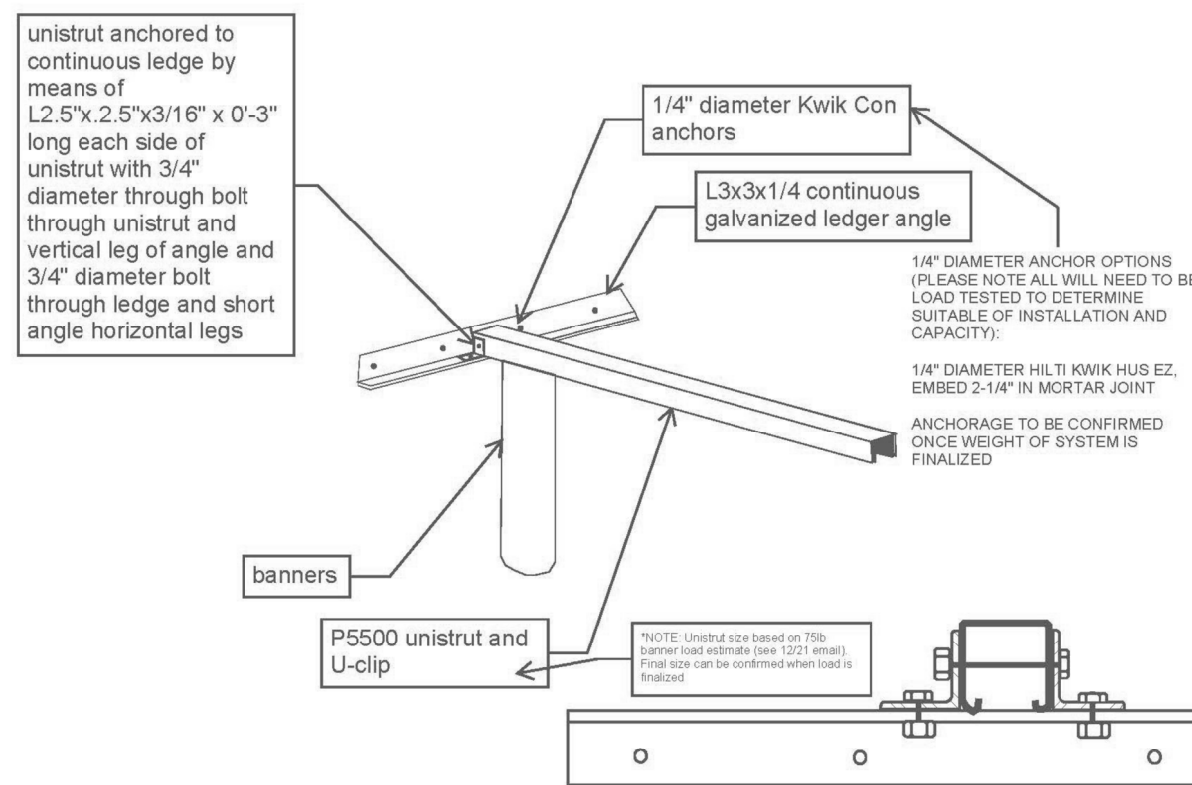

4 Typical Connection Between Alley Wall and Structural Members

NOT FOR CONSTRUCTION



Jefferson Lettieri Office

1105 Taughanock Blvd.
Ithaca, NY 14850
T +1 317 370 4336 (Michael Jefferson)
T +1 917 647 1491 (Suzanne Lettieri)

Ann Arbor Art Center (A2AC)
The Alleyway Project
Ann Arbor, MI

Key Plan and Legend

Alley located along W Washington St
between 113 W Washington St
and 200 South Main St

Notes

Above ground clearance of 15' required
by the city

Not for construction

Revisions

1/6/2022		

Structural
Details

PROJ. NO.: A2AC	DATE: 1/6/2022
DWG. BY: MJ	PAGE: 1XX of 1XX
© Jefferson Lettieri Office 2021	SCALE: 1/4"=1'

A500



drip

Jefferson Lettieri Office
Ann Arbor Art Center Alleyway Project

L3x3x1/4 continuous Galvanized ledger angle w/ 1/4" diameter Hilti Kwik-con plus anchors (embed 2-3/8") spaced 8" o.c. along length of wall. First anchor to be inset 6" from edge of wall.

1. Anchors are to be installed into mortar joints measuring 3/8" thick or more.
2. There should be no less than 2 anchors per banner at each end of banner.
3. Anchors are to be load tested prior to installation.

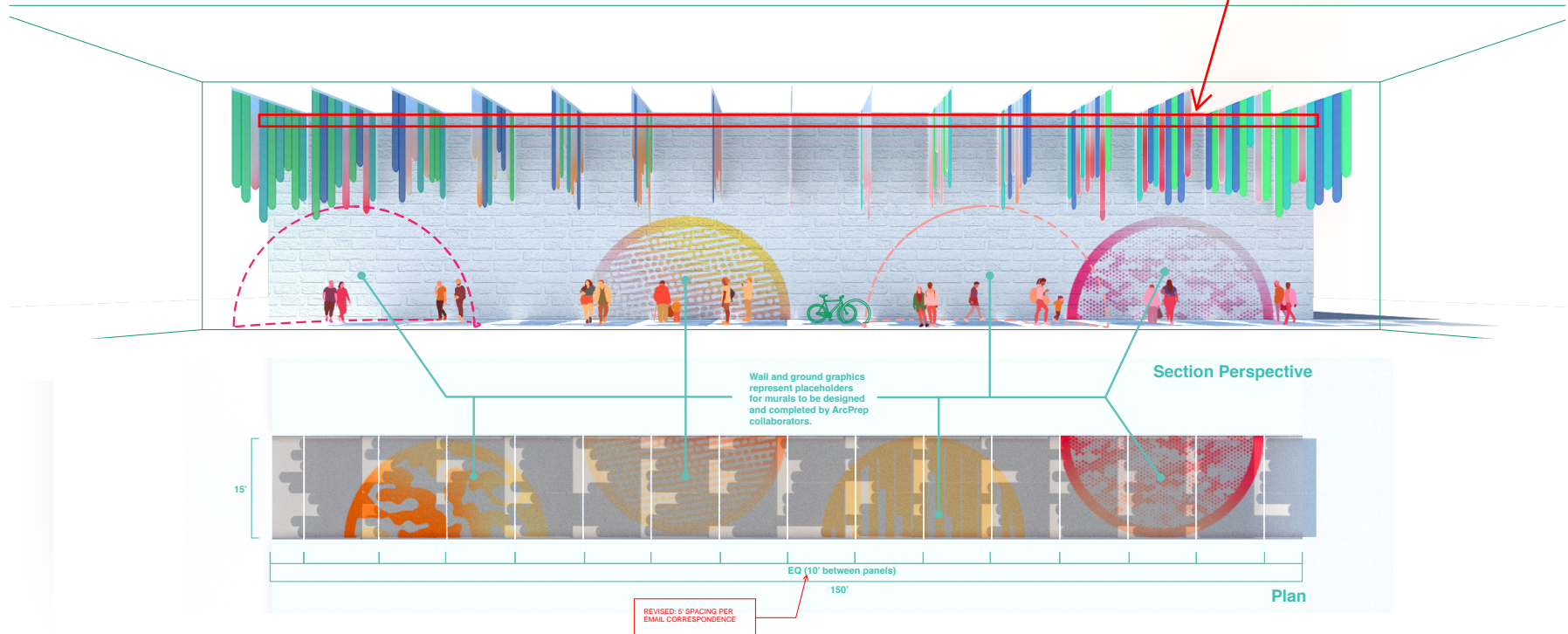

Jefferson Lettieri Office
Ann Arbor Art Center Alleyway Project

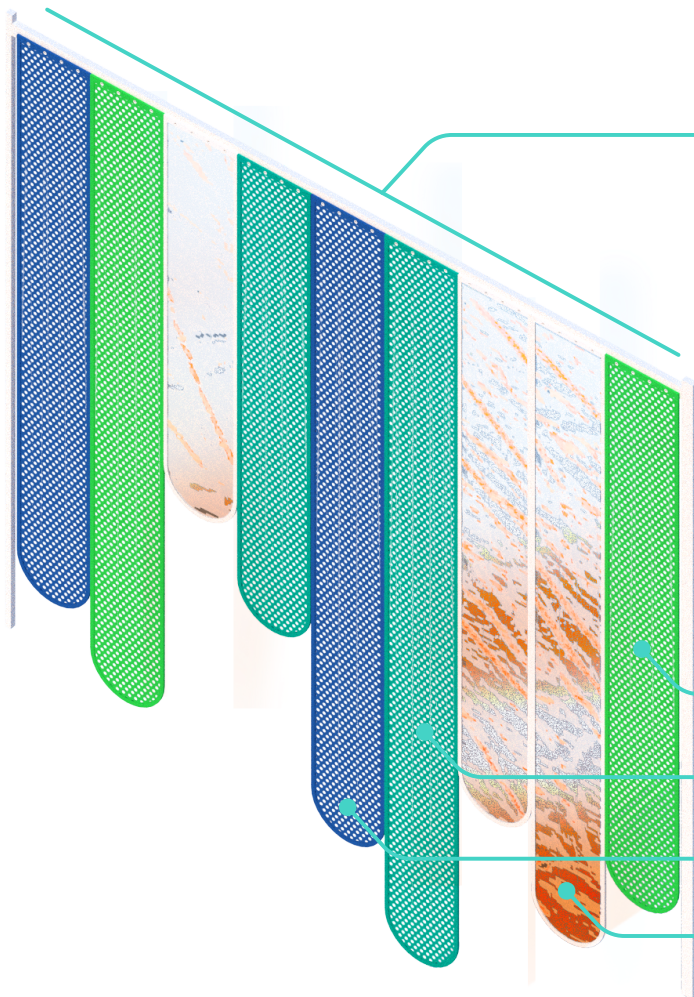

Individual fabric pieces attached to 1.5" x 1.5" steel square tube.

Slotted unistrut tube. Mounted to existing alley walls. Slots allow for adjustment of height of panels.

Panel Type A (green)

Panel Type B (teal)

Panel Type C (blue)

Panel Type D (reflective film)



Jefferson Lettieri Office
Ann Arbor Art Center Alleyway Project

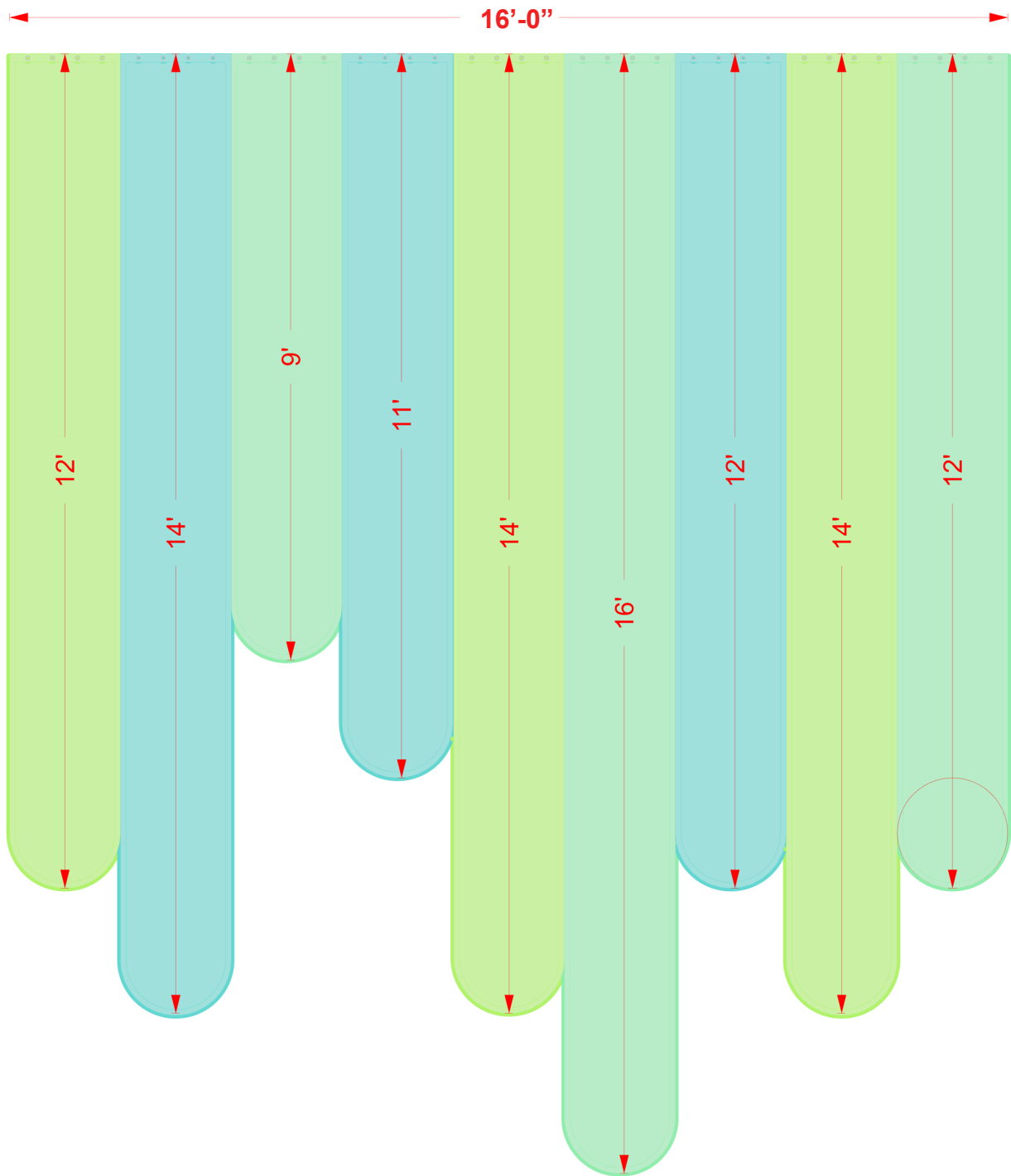

ASSEMBLED PANEL (9 FABRIC STRIPS OF VARYING LENGTH, 3 COLORS)



Jefferson Lettieri Office
Ann Arbor Art Center Alleyway Project

GROMMETS (NUMBER AND DIMENSION TBD)

HEM TBD

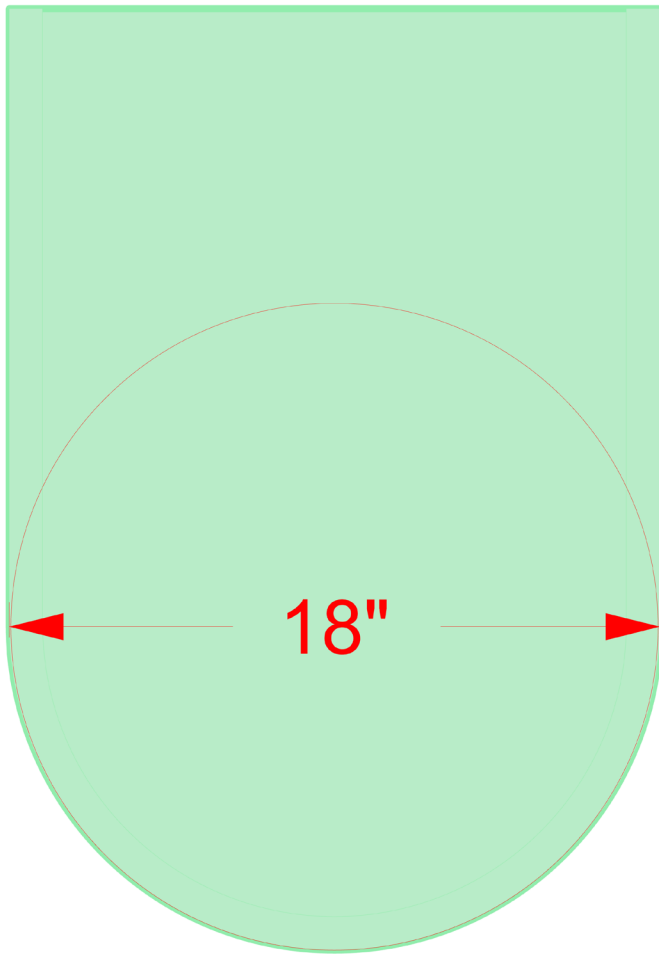
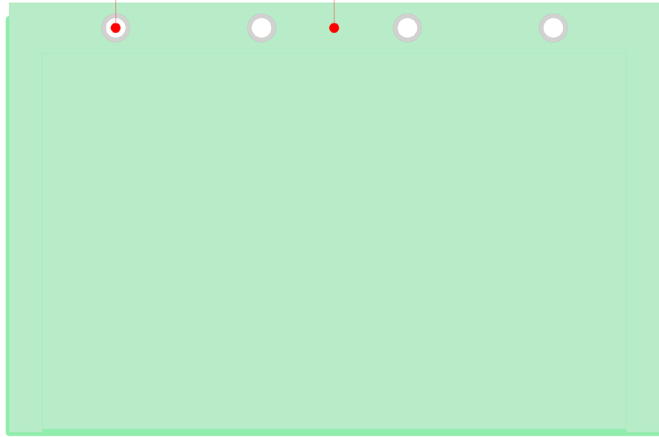

DETAIL (NOT TO SCALE)