

CITY OF ANN ARBOR
INVITATION TO BID



Veteran's Memorial Park Pool Waterslide Stair Improvements

ITB No. 4634

Due Date: Wednesday, June 24, 2020 at 2 p.m. (Local Time)

Parks and Recreation Services
Community Services Area

Issued By:

City of Ann Arbor
Procurement Unit
301 E. Huron Street
Ann Arbor, MI 48104

TABLE OF CONTENTS

TABLE OF CONTENTS.....	TC-1
NOTICE OF PRE-BID CONFERENCE.....	NP-1
INSTRUCTIONS TO BIDDERS.....	IB-1 to 6
INVITATION TO BID.....	ITB-1 to 3
BID FORMS.....	BF-1 to 5
CONTRACT.....	C-1 to 4
BOND FORMS.....	B-1 to 2
GENERAL CONDITIONS.....	GC-1 to 18
STANDARD SPECIFICATIONS.....	SS-1
DETAILED SPECIFICATION.....	DS-1 to DS-81
GENERAL REQUIREMENTS/SUMMARY OF WORK	
01100 Summary	
01110 Permit Requirements	
01310 Schedule Requirements	
01330 Color Audio-Video Survey of Construction Areas	
01340 Submittal Procedures	
01500 Construction Facilities and Temporary Controls	
01600 Materials and Equipment	
01710 Cleaning	
Michigan Department of Transportation 2012 Standard Specifications for Construction (portions)	
APPENDIX.....	APDX-1
Log of Project (1-7)	

ATTACHMENTS

City of Ann Arbor Prevailing Wage Declaration Form
City of Ann Arbor Living Wage Forms
City of Ann Arbor Vendor Conflict of Interest Disclosure Form
City of Ann Arbor Non-Discrimination Ordinance Declaration Form and Notice

NOTICE OF PRE-BID CONFERENCE

A pre-bid conference for this project will be held on **Wednesday, June 10, 2020, 2 p.m.** at the **Veterans Memorial Pool and Ice Arena at 2150 Jackson Avenue, Ann Arbor, MI 48103.**

Attendance at this conference is highly recommended. Administrative and technical questions regarding this project will be answered at this time. The pre-bid conference is for information only. Any answers furnished will not be official until verified in writing by the Financial Service Area, Procurement Unit. Answers that change or substantially clarify the bid will be affirmed in an addendum.

Face masks and social distancing guidelines will be followed at this meeting.

INSTRUCTIONS TO BIDDERS

General

Work to be done under this Contract is generally described through the detailed specifications and must be completed fully in accordance with the contract documents. All work to be done under this Contract is located in or near the City of Ann Arbor.

Any Bid which does not conform fully to these instructions may be rejected.

Preparation of Bids

Bids should be prepared providing a straight-forward, concise description of the Bidder's ability to meet the requirements of the ITB. Bids shall be written in ink or typewritten. No erasures are permitted. Mistakes may be crossed out and corrected and must be initialed and dated in ink by the person signing the Bid.

Bids must be submitted on the "Bid Forms" provided with each blank properly filled in. If forms are not fully completed it may disqualify the bid. No alternative bid will be considered unless alternative bids are specifically requested. If alternatives are requested, any deviation from the specification must be fully described, in detail on the "Alternate" section of Bid form.

Each person signing the Bid certifies that he/she is the person in the Bidder's firm/organization responsible for the decision as to the fees being offered in the Bid and has not and will not participated in any action contrary to the terms of this provision.

Questions or Clarifications / Designated City Contacts

All questions regarding this ITB shall be submitted via email. Emailed questions and inquires will be accepted from any and all prospective Bidders in accordance with the terms and conditions of the ITB.

All questions shall be due on or before **Friday, June 12, 2020 at 5 p.m.** and should be addressed as follows:

Specification/Scope of Work questions emailed to both fercho@a2gov.org and DSchultz@rowepsc.com.

Bid Process and Compliance questions emailed to cspencer@a2gov.org.

Any error, omissions or discrepancies in the specification discovered by a prospective contractor and/or service provider shall be brought to the attention of **Adam Fercho** at fercho@a2gov.org after discovery as possible. Further, the contractor and/or service provide shall not be allowed to take advantage of errors, omissions or discrepancies in the specifications.

Addenda

If it becomes necessary to revise any part of the ITB, notice of the Addendum will be posted to Michigan Inter-governmental Trade Network (MITN) www.mitn.info and/or City of Ann Arbor web site www.A2gov.org for all parties to download.

Each Bidder must in its Bid, to avoid any miscommunications, acknowledge all addenda which it has received, but the failure of a Bidder to receive, or acknowledge receipt of; any addenda shall not relieve the Bidder of the responsibility for complying with the terms thereof.

The City will not be bound by oral responses to inquiries or written responses other than written addenda.

Bid Submission

All Bids are due and must be delivered to the City of Ann Arbor Procurement Unit on or before **Wednesday, June 24, 2020 at 2:00 p.m. (local time)**. Bids submitted late or via oral, telephonic, telegraphic, electronic mail or facsimile **will not** be considered or accepted.

Each Bidder must submit one (1) original Bid and **three (3)** Bid copies in a sealed envelope clearly marked: **ITB No. 4634 - Veterans Memorial Park Pool Waterslide Stair Improvements**.

Bids must be addressed and delivered to:

City of Ann Arbor
Procurement Unit,
c/o Customer Services, 1st Floor
301 East Huron Street
Ann Arbor, MI 48104

All Bids received on or before the Due Date will be publicly opened and recorded immediately. No immediate decisions are rendered.

The following forms provided within this ITB Document must be included in submitted bids.

- **City of Ann Arbor Prevailing Wage Declaration of Compliance**
- **City of Ann Arbor Living Wage Ordinance Declaration of Compliance**
- **Vendor Conflict of Interest Disclosure Form**
- **City of Ann Arbor Non-Discrimination Ordinance Declaration of Compliance**

Bids that fail to provide these forms listed above upon bid opening will be rejected as non-responsive and will not be considered for award.

Hand delivered bids may be dropped off in the Purchasing drop box located in the Ann Street (north) vestibule of City Hall. The City will not be liable to any Bidder for any unforeseen circumstances, delivery or postal delays. Postmarking to the Due Date will not substitute for receipt of the Bid. Each Bidder is responsible for submission of their Bid.

Additional time for submission of bids past the stated due date and time will not be granted to a single Bidder; however, additional time may be granted to all Bidders when the City determines in its sole discretion that circumstances warrant it.

Award

The City intends to award a Contract(s) to the lowest responsible Bidder(s). On multi-divisional contracts, separate divisions may be awarded to separate Bidders. The City may also utilize alternatives offered in the Bid Forms, if any, to determine the lowest responsible Bidder on each division, and award multiple divisions to a single Bidder, so that the lowest total cost is achieved.

for the City. For unit price bids, the Contract will be awarded based upon the unit prices and the lump sum prices stated by the bidder for the work items specified in the bid documents, with consideration given to any alternates selected by the City. If the City determines that the unit price for any item is materially different for the work item bid than either other bidders or the general market, the City, in its sole discretion, in addition to any other right it may have, may reject the bid as not responsible or non-conforming.

The acceptability of major subcontractors will be considered in determining if a Bidder is responsible. In comparing Bids, the City will give consideration to alternate Bids for items listed in the bid forms. All key staff and subcontractors are subject to the approval by the City.

Official Documents

The City of Ann Arbor officially distributes bid documents from the Procurement Unit or through the Michigan Intergovernmental Trade Network (MITN). Copies of the bid documents obtained from any other source are not Official copies. Addenda and other bid information will only be posted to these official distribution sites. If you obtained City of Ann Arbor Bid documents from other sources, it is recommended that you register on www.MITN.info and obtain an official Bid. Bidders do not need to be shown on the plan holders list provided by MITN to be considered an official plan holder.

Bid Security

Each bid must be accompanied by a certified check, or Bid Bond by a surety licensed and authorized to do business within the State of Michigan, in the amount of 5% of the total of the bid price.

Withdrawal of Bids

After the time of opening, no Bid may be withdrawn for the period of **one hundred twenty (120)** days

Contract Time

Time is of the essence in the performance of the work under this Contract. The available time for work under this Contract is indicated on page C-2, Article III of the Contract. If these time requirements can not be met, the Bidder must stipulate on Bid Form Section 3 - Time Alternate its schedule for performance of the work. Consideration will be given to time in evaluating bids.

Liquidated Damages

A liquidated damages clause, as given on page C-2, Article III of the Contract, provides that the Contractor shall pay the City as liquidated damages, and not as a penalty, a sum certain per day for each and every day that the Contractor may be in default of completion of the specified work, within the time(s) stated in the Contract, or written extensions.

Liquidated damages clauses, as given in the General Conditions, provide further that the City shall be entitled to impose and recover liquidated damages for breach of the obligations under Chapter 112 of the City Code.

The liquidated damages are for the non-quantifiable aspects of any of the previously identified events and do not cover actual damages that can be shown or quantified nor are they intended to preclude recovery of actual damages in addition to the recovery of liquidated damages.

Human Rights Information

All contractors proposing to do business with the City shall satisfy the contract compliance administrative policy adopted by the City Administrator in accordance with the Section 9:158 of the Ann Arbor City Code. Breach of the obligation not to discriminate as outlined in Section 5, beginning at page GC-2 shall be a material breach of the contract. Contractors are required to post a copy of Ann Arbor's Non-Discrimination Ordinance attached at all work locations where its employees provide services under a contract with the City.

Wage Requirements

Section 4, beginning at page GC-1, outlines the requirements for payment of prevailing wages and for payment of a "living wage" to employees providing service to the City under this contract. The successful bidder and its subcontractors must comply with all applicable requirements and provide proof of compliance.

Pursuant to Resolution R-16-469 all public improvement contractors are subject to prevailing wage and will be required to provide to the City payroll records sufficient to demonstrate compliance with the prevailing wage requirements. Use of the Prevailing Wage Form provided in the Appendix section or a City-approved equivalent will be required along with wage rate interviews.

For laborers whose wage level are subject to federal, state and/or local prevailing wage law the appropriate Davis-Bacon wage rate classification is identified based upon the work including within this contract. **The wage determination(s) current on the date 10 days before bids are due shall apply to this contract.** The U.S. Department of Labor (DOL) has provided explanations to assist with classification in the following resource link: beta.SAM.gov.

For the purposes of this ITB the Construction Type of Building will apply.

Conflict Of Interest Disclosure

The City of Ann Arbor Purchasing Policy requires that prospective Vendors complete a Conflict of Interest Disclosure form. A contract may not be awarded to the selected Vendor unless and until the Procurement Unit and the City Administrator have reviewed the Disclosure form and determined that no conflict exists under applicable federal, state, or local law or administrative regulation. Not every relationship or situation disclosed on the Disclosure Form may be a disqualifying conflict. Depending on applicable law and regulations, some contracts may awarded on the recommendation of the City Administrator after full disclosure, where such action is allowed by law, if demonstrated competitive pricing exists and/or it is determined the award is in the best interest of the City. A copy of the Vendor Conflict of Interest Disclosure Form is attached.

Major Subcontractors

The Bidder shall identify on Bid Form Section 4 each major subcontractor it expects to engage for this Contract if the work to be subcontracted is 15% or more of the bid sum or over \$50,000, whichever is less. The Bidder also shall identify the work to be subcontracted to each major subcontractor. The Bidder shall not change or replace a subcontractor without approval by the City.

Debarment

Submission of a Bid in response to this ITB is certification that the Bidder is not currently debarred,

suspended, proposed for debarment, and declared ineligible or voluntarily excluded from participation in this transaction by any State or Federal departments or agency. Submission is also agreement that the City will be notified of any changes in this status.

Disclosures

After bids are opened, all information in a submitter's bid is subjected to disclosure under the provisions of Michigan Public Act No. 442 of 1976, as amended (MCL 15.231 et seq.) known as the "Freedom of Information Act." The Freedom of Information Act also provides for the complete disclosure of contracts and attachments thereto except where specifically exempted.

Bid Protest

All Bid protests must be in writing and filed with the Purchasing Agent within five (5) business days of the award action. The bidder must clearly state the reasons for the protest. If a bidder contacts a City Service Area/Unit and indicates a desire to protest an award, the Service Area/Unit shall refer the bidder to the Purchasing Agent. The Purchasing Agent will provide the bidder with the appropriate instructions for filing the protest. The protest shall be reviewed by the City Administrator or designee whose decision shall be final.

Any inquiries or requests regarding this procurement should be only submitted in writing to the Designated City Contacts provided herein. Attempts by any prospective bidder to initiate contact with anyone other than the Designated City Contacts provided herein that the bidder believes can influence the procurement decision, e.g., Elected Officials, City Administrator, Selection Committee Members, Appointed Committee Members, etc., may lead to immediate elimination from further consideration.

Cost Liability

The City of Ann Arbor assumes no responsibility or liability for costs incurred by the Bidder prior to the execution of a contract with the City. By submitting a bid, a bidder agrees to bear all costs incurred or related to the preparation, submission and selection process for the bid.

Reservation of Rights

The City of Ann Arbor reserves the right to accept any bid or alternative bid proposed in whole or in part, to reject any or all bids or alternatives bids in whole or in part and to waive irregularity and/or informalities in any bid and to make the award in any manner deemed in the best interest of the City.

Idlefree Ordinance

The City of Ann Arbor adopted an idling reduction Ordinance that goes into effect July 1, 2017. The full text of the ordinance (including exemptions) can be found at: www.a2gov.org/idlefree.

Under the ordinance, No Operator of a Commercial Vehicle shall cause or permit the Commercial Vehicle to Idle:

- (a) For any period of time while the Commercial Vehicle is unoccupied; or
- (b) For more than 5 minutes in any 60-minute period while the Commercial Vehicle is occupied.

In addition, generators and other internal combustion engines are covered

(1) Excluding Motor Vehicle engines, no internal combustion engine shall be operated except when it is providing power or electrical energy to equipment or a tool that is actively in use.

Environmental Commitment

The City of Ann Arbor recognizes its responsibility to minimize negative impacts on human health and the environment while supporting a vibrant community and economy. The City further recognizes that the products and services the City buys have inherent environmental and economic impacts and that the City should make procurement decisions that embody, promote, and encourage the City's commitment to the environment.

The City encourages potential vendors to bring forward emerging and progressive products and services that are best suited to the City's environmental principles.

INVITATION TO BID

City of Ann Arbor
Guy C. Larcom Municipal Building
Ann Arbor, Michigan 48107

Ladies and Gentlemen:

The undersigned, as Bidder, declares that this Bid is made in good faith, without fraud or collusion with any person or persons bidding on the same Contract; that this Bidder has carefully read and examined the bid documents, including City Nondiscrimination requirements and Declaration of Compliance Form, Living Wage requirements and Declaration of Compliance Form, Prevailing Wage requirements and Declaration of Compliance Form, Vendor Conflict of Interest Form, Notice of Pre-Bid Conference, Instructions to Bidders, Bid, Bid Forms, Contract, Bond Forms, General Conditions, Standard Specifications, Detailed Specifications, all Addenda, and the Plans (if applicable) and understands them. The Bidder declares that it conducted a full investigation at the site and of the work proposed and is fully informed as to the nature of the work and the conditions relating to the work's performance. The Bidder also declares that it has extensive experience in successfully completing projects similar to this one.

The Bidder acknowledges that it has not received or relied upon any representations or warrants of any nature whatsoever from the City of Ann Arbor, its agents or employees, and that this Bid is based solely upon the Bidder's own independent business judgment.

The undersigned proposes to perform all work shown on the plans or described in the bid documents, including any addenda issued, and to furnish all necessary machinery, tools, apparatus, and other means of construction to do all the work, furnish all the materials, and complete the work in strict accordance with all terms of the Contract of which this Bid is one part.

In accordance with these bid documents, and Addenda numbered _____, the undersigned, as Bidder, proposes to perform at the sites in and/or around Ann Arbor, Michigan, all the work included herein for the amounts set forth in the Bid Forms.

The Bidder declares that it has become fully familiar with the liquidated damage clauses for completion times and for compliance with City Code Chapter 112, understands and agrees that the liquidated damages are for the non-quantifiable aspects of non-compliance and do not cover actual damages that may be shown and agrees that if awarded the Contract, all liquidated damage clauses form part of the Contract.

The Bidder declares that it has become fully familiar with the provisions of Chapter 14, Section 1:320 (Prevailing wages) and Chapter 23 (Living Wage) of the Code of the City of Ann Arbor and that it understands and agrees to comply, to the extent applicable to employees providing services to the City under this Contract, with the wage and reporting requirements stated in the City Code provisions cited. Bidder certifies that the statements contained in the City Prevailing Wage and Living Wage Declaration of Compliance Forms are true and correct. Bidder further agrees that the cited provisions of Chapter 14 and Chapter 23 form a part of this Contract.

The Bidder declares that it has become familiar with the City Conflict of Interest Disclosure Form and certifies that the statement contained therein is true and correct.

The Bidder encloses a certified check or Bid Bond in the amount of 5% of the total of the Bid Price. The Bidder agrees both to contract for the work and to furnish the necessary Bonds and insurance documentation within 10 days after being notified of the acceptance of the Bid.

If this Bid is accepted by the City and the Bidder fails to contract and furnish the required Bonds and insurance documentation within 10 days after being notified of the acceptance of this Bid, then the Bidder shall be considered to have abandoned the Contract and the certified check or Bid Bond accompanying this Bid shall become due and payable to the City.

If the Bidder enters into the Contract in accordance with this Bid, or if this Bid is rejected, then the accompanying check or Bid Bond shall be returned to the Bidder.

In submitting this Bid, it is understood that the right is reserved by the City to accept any Bid, to reject any or all Bids, to waive irregularities and/or informalities in any Bid, and to make the award in any manner the City believes to be in its best interest.

SIGNED THIS _____ DAY OF _____, 202_.

Bidder's Name

Authorized Signature of Bidder

Official Address

(Print Name of Signer Above)

Telephone Number

Email Address for Award Notice

LEGAL STATUS OF BIDDER

(The Bidder shall fill out the appropriate form and strike out the other three.)

Bidder declares that it is:

* A corporation organized and doing business under the laws of the State of _____, for whom _____, bearing the office title of _____, whose signature is affixed to this Bid, is authorized to execute contracts.

NOTE: If not incorporated in Michigan, please attach the corporation's Certificate of Authority

• A limited liability company doing business under the laws of the State of _____, whom _____ bearing the title of _____ whose signature is affixed to this proposal, is authorized to execute contract on behalf of the LLC.

* A partnership, organized under the laws of the state of _____ and filed in the county of _____, whose members are (list all members and the street and mailing address of each) (attach separate sheet if necessary):

* An individual, whose signature with address, is affixed to this Bid: _____
(initial here)

Authorized Official

_____ **Date** _____, 202_

(Print) Name _____ Title _____

Company: _____

Address: _____

Contact Phone () _____ Fax () _____

Email _____

BID FORM

Section 1 – Schedule of Prices

Company: _____

Project: **ITB No. 4634 Veteran’s Memorial Park Pool Waterslide Stair Improvements**

Base Bid –

For the entire work outlined in these documents for **Veteran’s Memorial Park Pool Waterslide Stair Improvements**, complete as specified, using equipment and materials only of the type and manufacturers where specifically named.

Bid items include:

Remove and re-install railing (\$.....)

Repair, prepare and paint pool slide stair structure (\$.....)

Total Base Bid (\$.....)

Add Alternate #1

For the entire work outlined in these documents for Veteran’s Memorial Park Pool Waterslide Stair Improvements, replace structural steel features as approved by the owner and engineer, payment to be made on a per lb. material weighed prior to installation, cut to fit.

Add, per lb. _____ (\$.....)

Add Alternate #2

For the entire work outlined in these documents for Veteran’s Memorial Park Pool Waterslide Stair Improvements, provide additional guarantee for work and materials up to five years from final acceptance by the city.

Additional one year guarantee, each _____ (\$.....)

BID FORM

Section 2 – Material, Equipment and Environmental Alternates

The Base Bid proposal price shall include materials and equipment selected from the designated items and manufacturers listed in the bidding documents. This is done to establish uniformity in bidding and to establish standards of quality for the items named.

If the Contractor wishes to quote alternate items for consideration by the City, it may do so under this Section. A complete description of the item and the proposed price differential must be provided. Unless approved at the time of award, substitutions where items are specifically named will be considered only as a negotiated change in Contract Sum.

If an environmental alternative is bid the City strongly encourages bidders to provide recent examples of product testing and previous successful use for the City to properly evaluate the environmental alternative. Testing data from independent accredited organizations are strongly preferred.

<u>Item Number</u>	<u>Description</u>	<u>Add/Deduct Amount</u>
--------------------	--------------------	--------------------------

If the Bidder does not suggest any material or equipment alternate, the Bidder **MUST** complete the following statement:

For the work outlined in this request for bid, the bidder does NOT propose any material or equipment alternate under the Contract.

Signature of Authorized Representative of Bidder _____ Date _____

BID FORM

Section 3 - Time Alternate

If the Bidder takes exception to the time stipulated in Article III of the Contract, Time of Completion, page C-2, it is requested to stipulate below its proposed time for performance of the work. Consideration will be given to time in evaluating bids.

If the Bidder does not suggest any time alternate, the Bidder **MUST** complete the following statement:

For the work outlined in this request for bid, the bidder does NOT propose any time alternate under the Contract.

Signature of Authorized Representative of Bidder _____ Date _____

BID FORM

Section 4 - Major Subcontractors

For purposes of this Contract, a Subcontractor is anyone (other than the Contractor) who performs work (other than or in addition to the furnishing of materials, plans or equipment) at or about the construction site, directly or indirectly for or on behalf of the Contractor (and whether or not in privity of Contract with the Contractor), but shall not include any individual who furnishes merely the individual's own personal labor or services.

Contractor agrees that all subcontracts entered into by the Contractor shall contain similar wage provision to Section 4 of the General Conditions covering subcontractor's employees who perform work on this contract.

For the work outlined in these documents the Bidder expects to engage the following major subcontractors to perform the work identified:

<u>Subcontractor (Name and Address)</u>	<u>Work</u>	<u>Amount</u>
---	-------------	---------------

If the Bidder does not expect to engage any major subcontractor, the Bidder **MUST** complete the following statement:

For the work outlined in this request for bid, the bidder does NOT expect to engage any major subcontractor to perform work under the Contract.

Signature of Authorized Representative of Bidder _____ Date _____

Exhibit A

Quote Breakdown from Seaway Painting

Remove and Replace Wood Handrail	\$1,400
Clean and Coat Using Vapor Blast Unit.....	\$26,750
Steel Repairs	\$14,200

Total..... \$42,350

*Allowance for additional Steel Repairs..... \$10,000

**Additional Steel repairs/replacement will be approved by the city's engineering consultant after cleaning and removal of existing paint coatings.*

SAMPLE STANDARD CONTRACT

If a contract is awarded, the selected contractor will be required to adhere to a set of general contract provisions which will become a part of any formal agreement. These provisions are general principles which apply to all contractors of service to the City of Ann Arbor such as the following:

Administrative Use Only
Contract Date: _____

CONTRACT

THIS CONTRACT is between the CITY OF ANN ARBOR, a Michigan Municipal Corporation, 301 East Huron Street, Ann Arbor, Michigan 48104 ("City") and Seaway Painting L.L.C. ("Contractor")

Seaway Painting LLC. _____ 31801 Schoolcraft Road., Livonia, Michigan 48150-1808
(An individual/partnership/corporation, include state of incorporation) (Address)

Based upon the mutual promises below, the Contractor and the City agree as follows:

ARTICLE I - Scope of Work

The Contractor agrees to furnish all of the materials, equipment and labor necessary; and to abide by all the duties and responsibilities applicable to it for the project titled **ITB No. 4634 Veteran's Memorial Park Pool Waterslide Stair Improvements** in accordance with the requirements and provisions of the following documents, including all written modifications incorporated into any of the documents, all of which are incorporated as part of this Contract:

Non-discrimination and Living Wage Declaration of Compliance Forms (if applicable)	General Conditions
Vendor Conflict of Interest Form	Standard Specifications
Prevailing Wage Declaration of Compliance Form (if applicable)	Detailed Specifications
Bid Forms	Plans
Contract and Exhibits	Addenda
Bonds	

ARTICLE II - Definitions

Administering Service Area/Unit means **Parks and Recreation Services.**

Project means **ITB No. 4634 Veteran's Memorial Park Pool Waterslide Stair Improvements.**

Supervising Professional means the person acting under the authorization of the manager of the Administering Service Area/Unit. At the time this Contract is executed, the Supervising Professional is: **Adam Fercho** whose job title is **Park Planner & Landscape Architect**. If there is any question concerning who the Supervising Professional is, Contractor shall confirm with the manager of the Administering Service Area/Unit.

Contractor's Representative means **Steve Vlahakis** whose job title is **Project Manager**.

ARTICLE III - Time of Completion

- (A) The work to be completed under this Contract shall begin immediately on the date specified in the Notice to Proceed issued by the City.
- (B) The entire work for this Contract shall be completed within sixty (60) consecutive calendar days.
- (C) Failure to complete all the work within the time specified above, including any extension granted in writing by the Supervising Professional, shall obligate the Contractor to pay the City, as liquidated damages and not as a penalty, an amount equal to \$200 for each calendar day of delay in the completion of all the work. If any liquidated damages are unpaid by the Contractor, the City shall be entitled to deduct these unpaid liquidated damages from the monies due the Contractor.

The liquidated damages are for the non-quantifiable aspects of any of the previously identified events and do not cover actual damages that can be shown or quantified nor are they intended to preclude recovery of actual damages in addition to the recovery of liquidated damages.

ARTICLE IV - The Contract Sum

- (A) The City shall pay to the Contractor for the performance of the Contract, the lump sum price as given in the Bid Form in the amount of:

Fifty-Two Thousand Three Hundred Fifty and 00/100 Dollars (\$52,350.00)
- (B) The amount paid shall be equitably adjusted to cover changes in the work ordered by the Supervising Professional but not required by the Contract Documents. Increases or decreases shall be determined only by written agreement between the City and Contractor.

ARTICLE V - Assignment

This Contract may not be assigned or subcontracted any portion of any right or obligation under this contract without the written consent of the City. Notwithstanding any consent by the City to any assignment, Contractor shall at all times remain bound to all warranties, certifications, indemnifications, promises and performances, however described, as are required of it under this contract unless specifically released from the requirement, in writing, by the City.

ARTICLE VI - Choice of Law

This Contract shall be construed, governed, and enforced in accordance with the laws of the State of Michigan. By executing this Contract, the Contractor and the City agree to venue in a court of appropriate jurisdiction sitting within Washtenaw County for purposes of any action arising under this Contract. The parties stipulate that the venue referenced in this Contract is for convenience

and waive any claim of non-convenience.

Whenever possible, each provision of the Contract will be interpreted in a manner as to be effective and valid under applicable law. The prohibition or invalidity, under applicable law, of any provision will not invalidate the remainder of the Contract.

ARTICLE VII - Relationship of the Parties

The parties of the Contract agree that it is not a Contract of employment but is a Contract to accomplish a specific result. Contractor is an independent Contractor performing services for the City. Nothing contained in this Contract shall be deemed to constitute any other relationship between the City and the Contractor.

Contractor certifies that it has no personal or financial interest in the project other than the compensation it is to receive under the Contract. Contractor certifies that it is not, and shall not become, overdue or in default to the City for any Contract, debt, or any other obligation to the City including real or personal property taxes. City shall have the right to set off any such debt against compensation awarded for services under this Contract.

ARTICLE VIII - Notice

All notices given under this Contract shall be in writing, and shall be by personal delivery or by certified mail with return receipt requested to the parties at their respective addresses as specified in the Contract Documents or other address the Contractor may specify in writing. Notice will be deemed given on the date when one of the following first occur: (1) the date of actual receipt; or (2) three days after mailing certified U.S. mail.

ARTICLE IX - Indemnification

To the fullest extent permitted by law, Contractor shall indemnify, defend and hold the City, its officers, employees and agents harmless from all suits, claims, judgments and expenses including attorney's fees resulting or alleged to result, in whole or in part, from any act or omission, which is in any way connected or associated with this Contract, by the Contractor or anyone acting on the Contractor's behalf under this Contract. Contractor shall not be responsible to indemnify the City for losses or damages caused by or resulting from the City's sole negligence. The provisions of this Article shall survive the expiration or earlier termination of this contract for any reason.

ARTICLE X - Entire Agreement

This Contract represents the entire understanding between the City and the Contractor and it supersedes all prior representations, negotiations, agreements, or understandings whether written or oral. Neither party has relied on any prior representations in entering into this Contract. No terms or conditions of either party's invoice, purchase order or other administrative document shall modify the terms and conditions of this Contract, regardless of the other party's failure to object to such form. This Contract shall be binding on and shall inure to the benefit of the parties to this Contract and their permitted successors and permitted assigns and nothing in this Contract, express or implied, is intended to or shall confer on any other person or entity any legal or equitable right, benefit, or remedy of any nature whatsoever under or by reason of this Contract. This Contract may be altered, amended or modified only by written amendment signed by the City and the Contractor.

ARTICLE XI – ELECTRONIC TRANSACTIONS

The City and Contractor agree that signatures on this Contract may be delivered electronically in lieu of an original signature and agree to treat electronic signatures as original signatures that bind them to this Contract. This Contract may be executed and delivered by facsimile and upon such delivery, the facsimile signature will be deemed to have the same effect as if the original signature had been delivered to the other party.

FOR CONTRACTOR

By _____

Its: _____

FOR THE CITY OF ANN ARBOR

By _____
Christopher Taylor, Mayor

By _____
Jacqueline Beaudry, City Clerk

Approved as to substance

By _____
City Administrator

By _____
Services Area Administrator

Approved as to form and content

Stephen K. Postema, City Attorney

PERFORMANCE BOND

- (1) _____ (referred to as "Principal"),
and _____, a corporation duly authorized
to do business in the State of Michigan (referred to as "Surety"), are bound to the City of Ann Arbor,
Michigan (referred to as "City"), for \$ _____, the payment of which Principal and Surety bind
themselves, their heirs, executors, administrators, successors and assigns, jointly and severally,
by this bond.
- (2) The Principal has entered a written Contract with the City entitled _____
_____, for ITB No. _____ and this bond is given for that Contract in compliance with Act No. 213
of the Michigan Public Acts of 1963, as amended, being MCL 129.201 *et seq.*
- (3) Whenever the Principal is declared by the City to be in default under the Contract, the Surety may
promptly remedy the default or shall promptly:
- (a) complete the Contract in accordance with its terms and conditions; or
 - (b) obtain a bid or bids for submission to the City for completing the Contract in accordance with
its terms and conditions, and upon determination by Surety of the lowest responsible bidder,
arrange for a Contract between such bidder and the City, and make available, as work progresses,
sufficient funds to pay the cost of completion less the balance of the Contract price; but not
exceeding, including other costs and damages for which Surety may be liable hereunder, the
amount set forth in paragraph 1.
- (4) Surety shall have no obligation to the City if the Principal fully and promptly performs under the
Contract.
- (5) Surety agrees that no change, extension of time, alteration or addition to the terms of the Contract
or to the work to be performed thereunder, or the specifications accompanying it shall in any way
affect its obligations on this bond, and waives notice of any such change, extension of time,
alteration or addition to the terms of the Contract or to the work, or to the specifications.
- (6) Principal, Surety, and the City agree that signatures on this bond may be delivered electronically
in lieu of an original signature and agree to treat electronic signatures as original signatures that
bind them to this bond. This bond may be executed and delivered by facsimile and upon such
delivery, the facsimile signature will be deemed to have the same effect as if the original signature
had been delivered to the other party.

SIGNED AND SEALED this _____ day of _____, 202_.

(Name of Surety Company)

By _____
(Signature)

Its _____
(Title of Office)

Approved as to form:

Stephen K. Postema, City Attorney

(Name of Principal)

By _____
(Signature)

Its _____
(Title of Office)

Name and address of agent:

LABOR AND MATERIAL BOND

- (1) _____
of _____ (referred to as "Principal"), and _____, a corporation duly authorized to do business in the State of Michigan, (referred to as "Surety"), are bound to the City of Ann Arbor, Michigan (referred to as "City"), for the use and benefit of claimants as defined in Act 213 of Michigan Public Acts of 1963, as amended, being MCL 129.201 et seq., in the amount of \$ _____, for the payment of which Principal and Surety bind themselves, their heirs, executors, administrators, successors and assigns, jointly and severally, by this bond.
- (2) The Principal has entered a written Contract with the City entitled _____

_____, for ITB No. _____; and this bond is given for that Contract in compliance with Act No. 213 of the Michigan Public Acts of 1963 as amended;
- (3) If the Principal fails to promptly and fully repay claimants for labor and material reasonably required under the Contract, the Surety shall pay those claimants.
- (4) Surety's obligations shall not exceed the amount stated in paragraph 1, and Surety shall have no obligation if the Principal promptly and fully pays the claimants.
- (5) Principal, Surety, and the City agree that signatures on this bond may be delivered electronically in lieu of an original signature and agree to treat electronic signatures as original signatures that bind them to this bond. This bond may be executed and delivered by facsimile and upon such delivery, the facsimile signature will be deemed to have the same effect as if the original signature had been delivered to the other party.

SIGNED AND SEALED this _____ day of _____, 202__

(Name of Surety Company)

By _____
(Signature)

Its _____
(Title of Office)

Approved as to form:

Stephen K. Postema, City Attorney

(Name of Principal)

By _____
(Signature)

Its _____
(Title of Office)

Name and address of agent:

GENERAL CONDITIONS

Section 1 - Execution, Correlation and Intent of Documents

The contract documents shall be signed in 2 copies by the City and the Contractor.

The contract documents are complementary and what is called for by any one shall be binding. The intention of the documents is to include all labor and materials, equipment and transportation necessary for the proper execution of the work. Materials or work described in words which so applied have a well-known technical or trade meaning have the meaning of those recognized standards.

In case of a conflict among the contract documents listed below in any requirement(s), the requirement(s) of the document listed first shall prevail over any conflicting requirement(s) of a document listed later.

(1) Addenda in reverse chronological order; (2) Detailed Specifications; (3) Standard Specifications; (4) Plans; (5) General Conditions; (6) Contract; (7) Bid Forms; (8) Bond Forms; (9) Bid.

Section 2 - Order of Completion

The Contractor shall submit with each invoice, and at other times reasonably requested by the Supervising Professional, schedules showing the order in which the Contractor proposes to carry on the work. They shall include the dates at which the Contractor will start the several parts of the work, the estimated dates of completion of the several parts, and important milestones within the several parts.

Section 3 - Familiarity with Work

The Bidder or its representative shall make personal investigations of the site of the work and of existing structures and shall determine to its own satisfaction the conditions to be encountered, the nature of the ground, the difficulties involved, and all other factors affecting the work proposed under this Contract. The Bidder to whom this Contract is awarded will not be entitled to any additional compensation unless conditions are clearly different from those which could reasonably have been anticipated by a person making diligent and thorough investigation of the site.

The Bidder shall immediately notify the City upon discovery, and in every case prior to submitting its Bid, of every error or omission in the bidding documents that would be identified by a reasonably competent, diligent Bidder. In no case will a Bidder be allowed the benefit of extra compensation or time to complete the work under this Contract for extra expenses or time spent as a result of the error or omission.

Section 4 - Wage Requirements

Under this Contract, the Contractor shall conform to Chapter 14 of Title I of the Code of the City of Ann Arbor as amended; which in part states "...that all craftsmen, mechanics and laborers employed directly on the site in connection with said improvements, including said employees of

subcontractors, shall receive the prevailing wage for the corresponding classes of craftsmen, mechanics and laborers, as determined by statistics for the Ann Arbor area compiled by the United States Department of Labor. At the request of the City, any contractor or subcontractor shall provide satisfactory proof of compliance with the contract provisions required by the Section.

Pursuant to Resolution R-16-469 all public improvement contractors are subject to prevailing wage and will be required to provide to the City payroll records sufficient to demonstrate compliance with the prevailing wage requirements. A sample Prevailing Wage Form is provided in the Appendix herein for reference as to what will be expected from contractors. Use of the Prevailing Wage Form provided in the Appendix section or a City-approved equivalent will be required along with wage rate interviews.

Where the Contract and the Ann Arbor City Ordinance are silent as to definitions of terms required in determining contract compliance with regard to prevailing wages, the definitions provided in the Davis-Bacon Act as amended (40 U.S.C. 278-a to 276-a-7) for the terms shall be used.

If the Contractor is a "covered employer" as defined in Chapter 23 of the Ann Arbor City Code, the Contractor agrees to comply with the living wage provisions of Chapter 23 of the Ann Arbor City Code. The Contractor agrees to pay those employees providing Services to the City under this Contract a "living wage," as defined in Section 1:815 of the Ann Arbor City Code, as adjusted in accordance with Section 1:815(3); to post a notice approved by the City of the applicability of Chapter 23 in every location in which regular or contract employees providing services under this Contract are working; to maintain records of compliance; if requested by the City, to provide documentation to verify compliance; to take no action that would reduce the compensation, wages, fringe benefits, or leave available to any employee or person contracted for employment in order to pay the living wage required by Section 1:815; and otherwise to comply with the requirements of Chapter 23.

Contractor agrees that all subcontracts entered into by the Contractor shall contain similar wage provision covering subcontractor's employees who perform work on this contract.

Section 5 - Non-Discrimination

The Contractor agrees to comply, and to require its subcontractor(s) to comply, with the nondiscrimination provisions of MCL 37.2209. The Contractor further agrees to comply with the provisions of Section 9:158 of Chapter 112 of Title IX of the Ann Arbor City Code, and to assure that applicants are employed and that employees are treated during employment in a manner which provides equal employment opportunity.

Section 6 - Materials, Appliances, Employees

Unless otherwise stipulated, the Contractor shall provide and pay for all materials, labor, water, tools, equipment, light, power, transportation, and other facilities necessary or used for the execution and completion of the work. Unless otherwise specified, all materials incorporated in the permanent work shall be new, and both workmanship and materials shall be of the highest quality. The Contractor shall, if required, furnish satisfactory evidence as to the kind and quality of materials.

The Contractor shall at all times enforce strict discipline and good order among its employees, and shall seek to avoid employing on the work any unfit person or anyone not skilled in the work assigned.

Adequate sanitary facilities shall be provided by the Contractor.

Section 7 - Qualifications for Employment

The Contractor shall employ competent laborers and mechanics for the work under this Contract. For work performed under this Contract, employment preference shall be given to qualified local residents.

Section 8 - Royalties and Patents

The Contractor shall pay all royalties and license fees. It shall defend all suits or claims for infringements of any patent rights and shall hold the City harmless from loss on account of infringement except that the City shall be responsible for all infringement loss when a particular process or the product of a particular manufacturer or manufacturers is specified, unless the City has notified the Contractor prior to the signing of the Contract that the particular process or product is patented or is believed to be patented.

Section 9 - Permits and Regulations

The Contractor must secure and pay for all permits, permit or plan review fees and licenses necessary for the prosecution of the work. These include but are not limited to City building permits, right-of-way permits, lane closure permits, right-of-way occupancy permits, and the like. The City shall secure and pay for easements shown on the plans unless otherwise specified.

The Contractor shall give all notices and comply with all laws, ordinances, rules and regulations bearing on the conduct of the work as drawn and specified. If the Contractor observes that the contract documents are at variance with those requirements, it shall promptly notify the Supervising Professional in writing, and any necessary changes shall be adjusted as provided in the Contract for changes in the work.

Section 10 - Protection of the Public and of Work and Property

The Contractor is responsible for the means, methods, sequences, techniques and procedures of construction and safety programs associated with the work contemplated by this contract. The Contractor, its agents or sub-contractors, shall comply with the "General Rules and Regulations for the Construction Industry" as published by the Construction Safety Commission of the State of Michigan and to all other local, State and National laws, ordinances, rules and regulations pertaining to safety of persons and property.

The Contractor shall take all necessary and reasonable precautions to protect the safety of the public. It shall continuously maintain adequate protection of all work from damage, and shall take all necessary and reasonable precautions to adequately protect all public and private property from injury or loss arising in connection with this Contract. It shall make good any damage, injury or loss to its work and to public and private property resulting from lack of reasonable protective precautions, except as may be due to errors in the contract documents, or caused by agents or

employees of the City. The Contractor shall obtain and maintain sufficient insurance to cover damage to any City property at the site by any cause.

In an emergency affecting the safety of life, or the work, or of adjoining property, the Contractor is, without special instructions or authorization from the Supervising Professional, permitted to act at its discretion to prevent the threatened loss or injury. It shall also so act, without appeal, if authorized or instructed by the Supervising Professional.

Any compensation claimed by the Contractor for emergency work shall be determined by agreement or in accordance with the terms of Claims for Extra Cost - Section 15.

Section 11 - Inspection of Work

The City shall provide sufficient competent personnel for the inspection of the work.

The Supervising Professional shall at all times have access to the work whenever it is in preparation or progress, and the Contractor shall provide proper facilities for access and for inspection.

If the specifications, the Supervising Professional's instructions, laws, ordinances, or any public authority require any work to be specially tested or approved, the Contractor shall give the Supervising Professional timely notice of its readiness for inspection, and if the inspection is by an authority other than the Supervising Professional, of the date fixed for the inspection. Inspections by the Supervising Professional shall be made promptly, and where practicable at the source of supply. If any work should be covered up without approval or consent of the Supervising Professional, it must, if required by the Supervising Professional, be uncovered for examination and properly restored at the Contractor's expense.

Re-examination of any work may be ordered by the Supervising Professional, and, if so ordered, the work must be uncovered by the Contractor. If the work is found to be in accordance with the contract documents, the City shall pay the cost of re-examination and replacement. If the work is not in accordance with the contract documents, the Contractor shall pay the cost.

Section 12 - Superintendence

The Contractor shall keep on the work site, during its progress, a competent superintendent and any necessary assistants, all satisfactory to the Supervising Professional. The superintendent will be responsible to perform all on-site project management for the Contractor. The superintendent shall be experienced in the work required for this Contract. The superintendent shall represent the Contractor and all direction given to the superintendent shall be binding as if given to the Contractor. Important directions shall immediately be confirmed in writing to the Contractor. Other directions will be confirmed on written request. The Contractor shall give efficient superintendence to the work, using its best skill and attention.

Section 13 - Changes in the Work

The City may make changes to the quantities of work within the general scope of the Contract at any time by a written order and without notice to the sureties. If the changes add to or deduct from the extent of the work, the Contract Sum shall be adjusted accordingly. All the changes shall be executed under the conditions of the original Contract except that any claim for extension of time

caused by the change shall be adjusted at the time of ordering the change.

In giving instructions, the Supervising Professional shall have authority to make minor changes in the work not involving extra cost and not inconsistent with the purposes of the work, but otherwise, except in an emergency endangering life or property, no extra work or change shall be made unless in pursuance of a written order by the Supervising Professional, and no claim for an addition to the Contract Sum shall be valid unless the additional work was ordered in writing.

The Contractor shall proceed with the work as changed and the value of the work shall be determined as provided in Claims for Extra Cost - Section 15.

Section 14 - Extension of Time

Extension of time stipulated in the Contract for completion of the work will be made if and as the Supervising Professional may deem proper under any of the following circumstances:

- (1) When work under an extra work order is added to the work under this Contract;
- (2) When the work is suspended as provided in Section 20;
- (3) When the work of the Contractor is delayed on account of conditions which could not have been foreseen, or which were beyond the control of the Contractor, and which were not the result of its fault or negligence;
- (4) Delays in the progress of the work caused by any act or neglect of the City or of its employees or by other Contractors employed by the City;
- (5) Delay due to an act of Government;
- (6) Delay by the Supervising Professional in the furnishing of plans and necessary information;
- (7) Other cause which in the opinion of the Supervising Professional entitles the Contractor to an extension of time.

The Contractor shall notify the Supervising Professional within 7 days of an occurrence or conditions which, in the Contractor's opinion, entitle it to an extension of time. The notice shall be in writing and submitted in ample time to permit full investigation and evaluation of the Contractor's claim. The Supervising Professional shall acknowledge receipt of the Contractor's notice within 7 days of its receipt. Failure to timely provide the written notice shall constitute a waiver by the Contractor of any claim.

In situations where an extension of time in contract completion is appropriate under this or any other section of the contract, the Contractor understands and agrees that the only available adjustment for events that cause any delays in contract completion shall be extension of the required time for contract completion and that there shall be no adjustments in the money due the Contractor on account of the delay.

Section 15 - Claims for Extra Cost

If the Contractor claims that any instructions by drawings or other media issued after the date of the Contract involved extra cost under this Contract, it shall give the Supervising Professional written notice within 7 days after the receipt of the instructions, and in any event before proceeding to execute the work, except in emergency endangering life or property. The procedure shall then be as provided for Changes in the Work-Section I3. No claim shall be valid unless so made.

If the Supervising Professional orders, in writing, the performance of any work not covered by the contract documents, and for which no item of work is provided in the Contract, and for which no unit price or lump sum basis can be agreed upon, then the extra work shall be done on a Cost-Plus-Percentage basis of payment as follows:

- (1) The Contractor shall be reimbursed for all reasonable costs incurred in doing the work, and shall receive an additional payment of 15% of all the reasonable costs to cover both its indirect overhead costs and profit;
- (2) The term "Cost" shall cover all payroll charges for employees and supervision required under the specific order, together with all worker's compensation, Social Security, pension and retirement allowances and social insurance, or other regular payroll charges on same; the cost of all material and supplies required of either temporary or permanent character; rental of all power-driven equipment at agreed upon rates, together with cost of fuel and supply charges for the equipment; and any costs incurred by the Contractor as a direct result of executing the order, if approved by the Supervising Professional;
- (3) If the extra is performed under subcontract, the subcontractor shall be allowed to compute its charges as described above. The Contractor shall be permitted to add an additional charge of 5% percent to that of the subcontractor for the Contractor's supervision and contractual responsibility;
- (4) The quantities and items of work done each day shall be submitted to the Supervising Professional in a satisfactory form on the succeeding day, and shall be approved by the Supervising Professional and the Contractor or adjusted at once;
- (5) Payments of all charges for work under this Section in any one month shall be made along with normal progress payments. Retainage shall be in accordance with Progress Payments-Section 16.

No additional compensation will be provided for additional equipment, materials, personnel, overtime or special charges required to perform the work within the time requirements of the Contract.

When extra work is required and no suitable price for machinery and equipment can be determined in accordance with this Section, the hourly rate paid shall be 1/40 of the basic weekly rate listed in the Rental Rate Blue Book published by Dataquest Incorporated and applicable to the time period the equipment was first used for the extra work. The hourly rate will be deemed to include all costs of operation such as bucket or blade, fuel, maintenance, "regional factors", insurance, taxes, and the like, but not the costs of the operator.

Section 16 - Progress Payments

The Contractor shall submit each month, or at longer intervals, if it so desires, an invoice covering work performed for which it believes payment, under the Contract terms, is due. The submission shall be to the City's Finance Department - Accounting Division. The Supervising Professional will, within 10 days following submission of the invoice, prepare a certificate for payment for the work in an amount to be determined by the Supervising Professional as fairly representing the acceptable work performed during the period covered by the Contractor's invoice. To insure the proper performance of this Contract, the City will retain a percentage of the estimate in accordance with Act 524, Public Acts of 1980. The City will then, following the receipt of the Supervising Professional's Certificate, make payment to the Contractor as soon as feasible, which is anticipated will be within 15 days.

An allowance may be made in progress payments if substantial quantities of permanent material have been delivered to the site but not incorporated in the completed work if the Contractor, in the opinion of the Supervising Professional, is diligently pursuing the work under this Contract. Such materials shall be properly stored and adequately protected. Allowance in the estimate shall be at the invoice price value of the items. Notwithstanding any payment of any allowance, all risk of loss due to vandalism or any damages to the stored materials remains with the Contractor.

In the case of Contracts which include only the Furnishing and Delivering of Equipment, the payments shall be; 60% of the Contract Sum upon the delivery of all equipment to be furnished, or in the case of delivery of a usable portion of the equipment in advance of the total equipment delivery, 60% of the estimated value of the portion of the equipment may be paid upon its delivery in advance of the time of the remainder of the equipment to be furnished; 30% of the Contract Sum upon completion of erection of all equipment furnished, but not later than 60 days after the date of delivery of all of the equipment to be furnished; and payment of the final 10% on final completion of erection, testing and acceptance of all the equipment to be furnished; but not later than 180 days after the date of delivery of all of the equipment to be furnished, unless testing has been completed and shows the equipment to be unacceptable.

With each invoice for periodic payment, the Contractor shall enclose a Contractor's Declaration - Section 43, and an updated project schedule per Order of Completion - Section 2.

Section 17 - Deductions for Uncorrected Work

If the Supervising Professional decides it is inexpedient to correct work that has been damaged or that was not done in accordance with the Contract, an equitable deduction from the Contract price shall be made.

Section 18 - Correction of Work Before Final Payment

The Contractor shall promptly remove from the premises all materials condemned by the Supervising Professional as failing to meet Contract requirements, whether incorporated in the work or not, and the Contractor shall promptly replace and re-execute the work in accordance with the Contract and without expense to the City and shall bear the expense of making good all work of other contractors destroyed or damaged by the removal or replacement.

If the Contractor does not remove the condemned work and materials within 10 days after written notice, the City may remove them and, if the removed material has value, may store the material

at the expense of the Contractor. If the Contractor does not pay the expense of the removal within 10 days thereafter, the City may, upon 10 days written notice, sell the removed materials at auction or private sale and shall pay to the Contractor the net proceeds, after deducting all costs and expenses that should have been borne by the Contractor. If the removed material has no value, the Contractor must pay the City the expenses for disposal within 10 days of invoice for the disposal costs.

The inspection or lack of inspection of any material or work pertaining to this Contract shall not relieve the Contractor of its obligation to fulfill this Contract and defective work shall be made good. Unsuitable materials may be rejected by the Supervising Professional notwithstanding that the work and materials have been previously overlooked by the Supervising Professional and accepted or estimated for payment or paid for. If the work or any part shall be found defective at any time before the final acceptance of the whole work, the Contractor shall forthwith make good the defect in a manner satisfactory to the Supervising Professional. The judgment and the decision of the Supervising Professional as to whether the materials supplied and the work done under this Contract comply with the requirements of the Contract shall be conclusive and final.

Section 19 - Acceptance and Final Payment

Upon receipt of written notice that the work is ready for final inspection and acceptance, the Supervising Professional will promptly make the inspection. When the Supervising Professional finds the work acceptable under the Contract and the Contract fully performed, the Supervising Professional will promptly sign and issue a final certificate stating that the work required by this Contract has been completed and is accepted by the City under the terms and conditions of the Contract. The entire balance found to be due the Contractor, including the retained percentage, shall be paid to the Contractor by the City within 30 days after the date of the final certificate.

Before issuance of final certificates, the Contractor shall file with the City:

- (1) The consent of the surety to payment of the final estimate;
- (2) The Contractor's Affidavit in the form required by Section 44.

In case the Affidavit or consent is not furnished, the City may retain out of any amount due the Contractor, sums sufficient to cover all lienable claims.

The making and acceptance of the final payment shall constitute a waiver of all claims by the City except those arising from:

- (1) unsettled liens;
- (2) faulty work appearing within 12 months after final payment;
- (3) hidden defects in meeting the requirements of the plans and specifications;
- (4) manufacturer's guarantees.

It shall also constitute a waiver of all claims by the Contractor, except those previously made and still unsettled.

Section 20 - Suspension of Work

The City may at any time suspend the work, or any part by giving 5 days notice to the Contractor in writing. The work shall be resumed by the Contractor within 10 days after the date fixed in the

written notice from the City to the Contractor to do so. The City shall reimburse the Contractor for expense incurred by the Contractor in connection with the work under this Contract as a result of the suspension.

If the work, or any part, shall be stopped by the notice in writing, and if the City does not give notice in writing to the Contractor to resume work at a date within 90 days of the date fixed in the written notice to suspend, then the Contractor may abandon that portion of the work suspended and will be entitled to the estimates and payments for all work done on the portions abandoned, if any, plus 10% of the value of the work abandoned, to compensate for loss of overhead, plant expense, and anticipated profit.

Section 21 - Delays and the City's Right to Terminate Contract

If the Contractor refuses or fails to prosecute the work, or any separate part of it, with the diligence required to insure completion, ready for operation, within the allowable number of consecutive calendar days specified plus extensions, or fails to complete the work within the required time, the City may, by written notice to the Contractor, terminate its right to proceed with the work or any part of the work as to which there has been delay. After providing the notice the City may take over the work and prosecute it to completion, by contract or otherwise, and the Contractor and its sureties shall be liable to the City for any excess cost to the City. If the Contractor's right to proceed is terminated, the City may take possession of and utilize in completing the work, any materials, appliances and plant as may be on the site of the work and useful for completing the work. The right of the Contractor to proceed shall not be terminated or the Contractor charged with liquidated damages where an extension of time is granted under Extension of Time - Section 14.

If the Contractor is adjudged a bankrupt, or if it makes a general assignment for the benefit of creditors, or if a receiver is appointed on account of its insolvency, or if it persistently or repeatedly refuses or fails except in cases for which extension of time is provided, to supply enough properly skilled workers or proper materials, or if it fails to make prompt payments to subcontractors or for material or labor, or persistently disregards laws, ordinances or the instructions of the Supervising Professional, or otherwise is guilty of a substantial violation of any provision of the Contract, then the City, upon the certificate of the Supervising Professional that sufficient cause exists to justify such action, may, without prejudice to any other right or remedy and after giving the Contractor 3 days written notice, terminate this Contract. The City may then take possession of the premises and of all materials, tools and appliances thereon and without prejudice to any other remedy it may have, make good the deficiencies or finish the work by whatever method it may deem expedient, and deduct the cost from the payment due the Contractor. The Contractor shall not be entitled to receive any further payment until the work is finished. If the expense of finishing the work, including compensation for additional managerial and administrative services exceeds the unpaid balance of the Contract Sum, the Contractor and its surety are liable to the City for any excess cost incurred. The expense incurred by the City, and the damage incurred through the Contractor's default, shall be certified by the Supervising Professional.

Section 22 - Contractor's Right to Terminate Contract

If the work should be stopped under an order of any court, or other public authority, for a period of 3 months, through no act or fault of the Contractor or of anyone employed by it, then the Contractor may, upon 7 days written notice to the City, terminate this Contract and recover from the City payment for all acceptable work executed plus reasonable profit.

Section 23 - City's Right To Do Work

If the Contractor should neglect to prosecute the work properly or fail to perform any provision of this Contract, the City, 3 days after giving written notice to the Contractor and its surety may, without prejudice to any other remedy the City may have, make good the deficiencies and may deduct the cost from the payment due to the Contractor.

Section 24 - Removal of Equipment and Supplies

In case of termination of this Contract before completion, from any or no cause, the Contractor, if notified to do so by the City, shall promptly remove any part or all of its equipment and supplies from the property of the City, failing which the City shall have the right to remove the equipment and supplies at the expense of the Contractor.

The removed equipment and supplies may be stored by the City and, if all costs of removal and storage are not paid by the Contractor within 10 days of invoicing, the City upon 10 days written notice may sell the equipment and supplies at auction or private sale, and shall pay the Contractor the net proceeds after deducting all costs and expenses that should have been borne by the Contractor and after deducting all amounts claimed due by any lien holder of the equipment or supplies.

Section 25 - Responsibility for Work and Warranties

The Contractor assumes full responsibility for any and all materials and equipment used in the construction of the work and may not make claims against the City for damages to materials and equipment from any cause except negligence or willful act of the City. Until its final acceptance, the Contractor shall be responsible for damage to or destruction of the project (except for any part covered by Partial Completion and Acceptance - Section 26). The Contractor shall make good all work damaged or destroyed before acceptance. All risk of loss remains with the Contractor until final acceptance of the work (Section 19) or partial acceptance (Section 26). The Contractor is advised to investigate obtaining its own builders risk insurance.

The Contractor shall guarantee the quality of the work for a period of one year. The Contractor shall also unconditionally guarantee the quality of all equipment and materials that are furnished and installed under the contract for a period of one year. At the end of one year after the Contractor's receipt of final payment, the complete work, including equipment and materials furnished and installed under the contract, shall be inspected by the Contractor and the Supervising Professional. Any defects shall be corrected by the Contractor at its expense as soon as practicable but in all cases within 60 days. Any defects that are identified prior to the end of one year shall also be inspected by the Contractor and the Supervising Professional and shall be corrected by the Contractor at its expense as soon as practicable but in all cases within 60 days. The Contractor shall assign all manufacturer or material supplier warranties to the City prior to final payment. The assignment shall not relieve the Contractor of its obligations under this paragraph to correct defects.

Section 26 - Partial Completion and Acceptance

If at any time prior to the issuance of the final certificate referred to in Acceptance and Final Payment - Section 19, any portion of the permanent construction has been satisfactorily completed, and if the Supervising Professional determines that portion of the permanent construction is not required for the operations of the Contractor but is needed by the City, the Supervising Professional shall issue to the Contractor a certificate of partial completion, and immediately the City may take over and use the portion of the permanent construction described in the certificate, and exclude the Contractor from that portion.

The issuance of a certificate of partial completion shall not constitute an extension of the Contractor's time to complete the portion of the permanent construction to which it relates if the Contractor has failed to complete it in accordance with the terms of this Contract. The issuance of the certificate shall not release the Contractor or its sureties from any obligations under this Contract including bonds.

If prior use increases the cost of, or delays the work, the Contractor shall be entitled to extra compensation, or extension of time, or both, as the Supervising Professional may determine.

Section 27 - Payments Withheld Prior to Final Acceptance of Work

The City may withhold or, on account of subsequently discovered evidence, nullify the whole or part of any certificate to the extent reasonably appropriate to protect the City from loss on account of:

- (1) Defective work not remedied;
- (2) Claims filed or reasonable evidence indicating probable filing of claims by other parties against the Contractor;
- (3) Failure of the Contractor to make payments properly to subcontractors or for material or labor;
- (4) Damage to another Contractor.

When the above grounds are removed or the Contractor provides a Surety Bond satisfactory to the City which will protect the City in the amount withheld, payment shall be made for amounts withheld under this section.

Section 28 - Contractor's Insurance

- (1) The Contractor shall procure and maintain during the life of this Contract, including the guarantee period and during any warranty work, such insurance policies, including those set forth below, as will protect itself and the City from all claims for bodily injuries, death or property damage that may arise under this Contract; whether the act(s) or omission(s) giving rise to the claim were made by the Contractor, any subcontractor, or anyone employed by them directly or indirectly. Prior to commencement of any work under this contract, Contractor shall provide to the City documentation satisfactory to the City, through City-approved means (currently myCOI), demonstrating it has obtained the required policies and endorsements. The certificates of insurance endorsements and/or copies of

policy language shall document that the Contractor satisfies the following minimum requirements. Contractor shall add registration@mycoitracking.com to its safe sender's list so that it will receive necessary communication from myCOI. When requested, Contractor shall provide the same documentation for its subcontractor(s) (if any).

Required insurance policies include:

- (a) Worker's Compensation Insurance in accordance with all applicable state and federal statutes. Further, Employers Liability Coverage shall be obtained in the following minimum amounts:

- Bodily Injury by Accident - \$500,000 each accident
 - Bodily Injury by Disease - \$500,000 each employee
 - Bodily Injury by Disease - \$500,000 each policy limit

- (b) Commercial General Liability Insurance equivalent to, as a minimum, Insurance Services Office form CG 00 01 04 13 or current equivalent. The City of Ann Arbor shall be named as an additional insured. There shall be no added exclusions or limiting endorsements specifically for the following coverages: Products and Completed Operations, Explosion, Collapse and Underground coverage or Pollution. Further there shall be no added exclusions or limiting endorsements that diminish the City's protections as an additional insured under the policy. The following minimum limits of liability are required:

- \$1,000,000 Each occurrence as respect Bodily Injury Liability or Property Damage Liability, or both combined.
 - \$2,000,000 Per Project General Aggregate
 - \$1,000,000 Personal and Advertising Injury
 - \$2,000,000 Products and Completed Operations Aggregate

- (c) Motor Vehicle Liability Insurance, including Michigan No-Fault Coverages, equivalent to, as a minimum, Insurance Services Office form CA 00 01 10 13 or current equivalent. Coverage shall include all owned vehicles, all non-owned vehicles and all hired vehicles. The City of Ann Arbor shall be named as an additional insured. There shall be no added exclusions or limiting endorsements that diminish the City's protections as an additional insured under the policy. Further, the limits of liability shall be \$1,000,000 for each occurrence as respects Bodily Injury Liability or Property Damage Liability, or both combined.

- (d) Umbrella/Excess Liability Insurance shall be provided to apply excess of the Commercial General Liability, Employers Liability and the Motor Vehicle coverage enumerated above, for each occurrence and for aggregate in the amount of \$1,000,000.

- (2) Insurance required under subsection (1)(b) and (1)(c) above shall be considered primary as respects any other valid or collectible insurance that the City may possess, including any self-insured retentions the City may have; and any other insurance the City does possess shall be considered excess insurance only and shall not be required to contribute with this insurance. Further, the Contractor agrees to waive any right of recovery by its insurer against the City for any insurance listed herein.

- (3) Insurance companies and policy forms are subject to approval of the City Attorney, which approval shall not be unreasonably withheld. Documentation must provide and demonstrate an unconditional and un-qualified 30-day written notice of cancellation in favor of the City of Ann Arbor. Further, the documentation must explicitly state the following: (a) the policy number(s); name of insurance company(s); name and address of the agent(s) or authorized representative(s); name(s), email address(es), and address of insured; project name; policy expiration date; and specific coverage amounts; (b) any deductibles or self-insured retentions which may be approved by the City, in its sole discretion; (c) that the policy conforms to the requirements specified Contractor shall furnish the City with satisfactory certificates of insurance and endorsements prior to commencement of any work. Upon request, the Contractor shall provide within 30 days a copy of the policy(ies) and all required endorsements to the City. If any of the above coverages expire by their terms during the term of this Contract, the Contractor shall deliver proof of renewal and/or new policies and endorsements to the Administering Service Area/Unit at least ten days prior to the expiration date.
- (4) Any Insurance provider of Contractor shall be authorized to do business in the State of Michigan and shall carry and maintain a minimum rating assigned by A.M. Best & Company's Key Rating Guide of "A-" Overall and a minimum Financial Size Category of "V". Insurance policies and certificates issued by non-authorized insurance companies are not acceptable unless approved in writing by the City.
- (5) City reserves the right to require additional coverage and/or coverage amounts as may be included from time to time in the Detailed Specifications for the Project.
- (6) The provisions of General Condition 28 shall survive the expiration or earlier termination of this contract for any reason.

Section 29 - Surety Bonds

Bonds will be required from the successful bidder as follows:

- (1) A Performance Bond to the City of Ann Arbor for the amount of the bid(s) accepted;
- (2) A Labor and Material Bond to the City of Ann Arbor for the amount of the bid(s) accepted.

Bonds shall be executed on forms supplied by the City in a manner and by a Surety Company authorized to transact business in Michigan and satisfactory to the City Attorney.

Section 30 - Damage Claims

The Contractor shall be held responsible for all damages to property of the City or others, caused by or resulting from the negligence of the Contractor, its employees, or agents during the progress of or connected with the prosecution of the work, whether within the limits of the work or elsewhere. The Contractor must restore all property injured including sidewalks, curbing, sodding, pipes, conduit, sewers or other public or private property to not less than its original condition with new work.

Section 31 - Refusal to Obey Instructions

If the Contractor refuses to obey the instructions of the Supervising Professional, the Supervising Professional shall withdraw inspection from the work, and no payments will be made for work performed thereafter nor may work be performed thereafter until the Supervising Professional shall have again authorized the work to proceed.

Section 32 - Assignment

Neither party to the Contract shall assign the Contract without the written consent of the other. The Contractor may assign any monies due to it to a third party acceptable to the City.

Section 33 - Rights of Various Interests

Whenever work being done by the City's forces or by other contractors is contiguous to work covered by this Contract, the respective rights of the various interests involved shall be established by the Supervising Professional, to secure the completion of the various portions of the work in general harmony.

The Contractor is responsible to coordinate all aspects of the work, including coordination of, and with, utility companies and other contractors whose work impacts this project.

Section 34 - Subcontracts

The Contractor shall not award any work to any subcontractor without prior written approval of the City. The approval will not be given until the Contractor submits to the City a written statement concerning the proposed award to the subcontractor. The statement shall contain all information the City may require.

The Contractor shall be as fully responsible to the City for the acts and omissions of its subcontractors, and of persons either directly or indirectly employed by them, as it is for the acts and omissions of persons directly employed by it.

The Contractor shall cause appropriate provisions to be inserted in all subcontracts relative to the work to bind subcontractors to the Contractor by the terms of the General Conditions and all other contract documents applicable to the work of the subcontractors and to give the Contractor the same power to terminate any subcontract that the City may exercise over the Contractor under any provision of the contract documents.

Nothing contained in the contract documents shall create any contractual relation between any subcontractor and the City.

Section 35 - Supervising Professional's Status

The Supervising Professional has the right to inspect any or all work. The Supervising Professional has authority to stop the work whenever stoppage may be appropriate to insure the proper execution of the Contract. The Supervising Professional has the authority to reject all work and materials which do not conform to the Contract and to decide questions which arise in the execution of the work.

The Supervising Professional shall make all measurements and determinations of quantities. Those measurements and determinations are final and conclusive between the parties.

Section 36 - Supervising Professional's Decisions

The Supervising Professional shall, within a reasonable time after their presentation to the Supervising Professional, make decisions in writing on all claims of the City or the Contractor and on all other matters relating to the execution and progress of the work or the interpretation of the contract documents.

Section 37 - Storing Materials and Supplies

Materials and supplies may be stored at the site of the work at locations agreeable to the City unless specific exception is listed elsewhere in these documents. Ample way for foot traffic and drainage must be provided, and gutters must, at all times, be kept free from obstruction. Traffic on streets shall be interfered with as little as possible. The Contractor may not enter or occupy with agents, employees, tools, or material any private property without first obtaining written permission from its owner. A copy of the permission shall be furnished to the Supervising Professional.

Section 38 - Lands for Work

The Contractor shall provide, at its own expense and without liability to the City, any additional land and access that may be required for temporary construction facilities or for storage of materials.

Section 39 - Cleaning Up

The Contractor shall, as directed by the Supervising Professional, remove at its own expense from the City's property and from all public and private property all temporary structures, rubbish and waste materials resulting from its operations unless otherwise specifically approved, in writing, by the Supervising Professional.

Section 40 - Salvage

The Supervising Professional may designate for salvage any materials from existing structures or underground services. Materials so designated remain City property and shall be transported or stored at a location as the Supervising Professional may direct.

Section 41 - Night, Saturday or Sunday Work

No night or Sunday work (without prior written City approval) will be permitted except in the case of an emergency and then only to the extent absolutely necessary. The City may allow night work which, in the opinion of the Supervising Professional, can be satisfactorily performed at night. Night work is any work between 8:00 p.m. and 7:00 a.m. No Saturday work will be permitted unless the Contractor gives the Supervising Professional at least 48 hours but not more than 5 days notice of the Contractor's intention to work the upcoming Saturday.

Section 42 - Sales Taxes

Under State law the City is exempt from the assessment of State Sales Tax on its direct purchases. Contractors who acquire materials, equipment, supplies, etc. for incorporation in City projects are not likewise exempt. State Law shall prevail. The Bidder shall familiarize itself with the State Law and prepare its Bid accordingly. No extra payment will be allowed under this Contract for failure of the Contractor to make proper allowance in this bid for taxes it must pay.

Section 43

CONTRACTOR'S DECLARATION

I hereby declare that I have not, during the period _____, 20___, to _____, 20___, performed any work, furnished any materials, sustained any loss, damage or delay, or otherwise done anything in addition to the regular items (or executed change orders) set forth in the Contract titled _____, for which I shall ask, demand, sue for, or claim compensation or extension of time from the City, except as I hereby make claim for additional compensation or extension of time as set forth on the attached itemized statement. I further declare that I have paid all payroll obligations related to this Contract that have become due during the above period and that all invoices related to this Contract received more than 30 days prior to this declaration have been paid in full except as listed below.

There is/is not (Contractor please circle one and strike one as appropriate) an itemized statement attached regarding a request for additional compensation or extension of time.

Contractor

Date

By _____
(Signature)

Its _____
(Title of Office)

Past due invoices, if any, are listed below.

STANDARD SPECIFICATIONS

All work under this contract shall be performed in accordance with the Public Services Department Standard Specifications in effect at the date of availability of the contract documents stipulated in the Bid. All work under this Contract which is not included in these Standard Specifications, or which is performed using modifications to these Standard Specifications, shall be performed in accordance with the Detailed Specifications included in these contract documents.

Standard Specifications are available online:

<http://www.a2gov.org/departments/engineering/Pages/Engineering-and-Contractor-Resources.aspx>

DETAILED SPECIFICATIONS

SECTION 01100
SUMMARY

PART 1 - GENERAL

1.01 Summary

This section includes project information, work covered by the contract documents, access to the site, work restrictions, and specification and drawing conventions.

1.02 Project Information

A. Project Identification

Veteran's Park Pool Slide Improvements

B. Project Location

City of Ann Arbor, Washtenaw County, Michigan

C. Project Address

Veteran's Memorial Park Pool and Ice Arena, 2150 Jackson Avenue, Ann Arbor, MI 48103

D. Owner

City of Ann Arbor Parks and Recreation Department, 301 East Huron Street, Ann Arbor, MI 48104

E. Engineer

ROWE Professional Services Company, 540 South Saginaw Street, Suite 200, Flint, MI 48502

1.03 Work Covered by Contract Documents

This project includes the removal and replacement of the pool slide stair wood handrail, repair, preparation, and repainting of pool slide stair structure, and associated protections.

1.04 Type of Contract

The project will be constructed under a single prime contract.

1.05 Access to Site

The Contractor will have full use of the project site; however, the Contractor shall confine activities and use of the premises to the areas required for the Contractor's work.

The Contractor shall limit construction activities to the areas designated on the plans for construction limits or activities.

Access to driveways, walkways, and entrances shall be maintained at all times.

1.06 Work Restrictions

The Contractor shall comply with local ordinances and authorities having jurisdiction.

Work activities at the site shall be limited to the period between 8 a.m. through 5 p.m., excluding weekends and holidays recognized by the City of Ann Arbor.

1.07 Specification and Drawing Conventions

The specifications use certain conventions for the style of language and the intended meaning of certain terms, words, and phrases when used in particular situations. The words “shall”, “shall be” or “shall comply with”, depending on the context, are implied where a colon is used within a sentence or phrase. Specification requirements are the Contractor’s responsibility unless specifically stated otherwise.

Requirements of Division 1 sections apply to the work of all sections in the specifications.

Requirements for materials and products identified on the drawings are described in detail in the specifications.

Requirements as listed in the Michigan Department of Transportation 2012 Standard Specifications for Construction.

PART 2 - PRODUCTS

Not Applicable

PART 3 - EXECUTION

Not Applicable

END OF SECTION

SECTION 01110
PERMIT REQUIREMENTS

PART 1 - GENERAL

1.01 Work Included

The Contractor shall complete work in accordance with all applicable regulations, laws, and ordinances. Work shall be completed in accordance with permits issued by regulatory agencies.

The Contractor shall obtain permits, including the paying of fees, posting bonds, and providing insurance coverage, to secure permits which have not been obtained by the Owner.

Where permits have been obtained by the Owner, the Contractor shall conduct work and operations consistent with the requirements of the permits.

Where changed conditions or other issues arise such that the conditions of a permit which has been issued cannot be met, the Contractor shall promptly notify the Owner and the permitting agency. The Contractor shall provide such additional information as may be necessary to secure a modification to the original permit to allow the planned work to continue.

PART 2 - PRODUCTS

Not Applicable

PART 3 - EXECUTION

3.01 Permits to be Obtained by Contractor

A. Other Permits to be Obtained by the Contractor

The Contractor is responsible to obtain all permits necessary to complete the proposed work, which have not been obtained by the Owner. This includes necessary building permit(s) from the City of Ann Arbor.

END OF SECTION

SECTION 01310
SCHEDULE REQUIREMENTS

PART 1 - GENERAL

1.01 Work Included

The Contractor shall develop a detailed schedule, identifying various phases or divisions of work, indicating a start date and duration required for each. The schedule shall be presented to the Engineer or Owner in sufficient detail, as may be required by the Engineer or Owner, for their approval.

Periodically through the life of the project and as required by the Engineer or Owner, the Contractor shall update the schedule and provide copies to the Engineer and Owner.

1.02 Requirements

The entire work under this contract shall be completed in accordance with, and subject to, the scheduling requirements as outlines below, and all other requirements of the contract documents.

- A. The Contractor shall begin the work of this project on or before September 7, 2020, and only upon receipt of the fully executed contract and Notice to Proceed. Appropriate time extensions shall be granted if the Notice to Proceed is delayed beyond this date.
- B. The entirety of work under this contract shall be completed by November 2, 2020.

The Contractor is expected to be furnished with three copies of the contract, for his/her execution, on or before August 21, 2020. The Contractor shall properly execute the contract and return them, with the required bonds and insurance certificate, to the city within ten days. The Contractor shall not begin the work before the applicable date(s) as described herein without approval from the Owner, and in no case before the receipt of the fully executed contract. City Council approval is expected by August 6, 2020.

The Contractor shall schedule work to be performed during normal business hours, unless otherwise directed on the plans or approved by the Engineer.

Once work has begun on the project, the Contractor shall work continuously and expeditiously to complete all work provided for by the contract.

Project shall be substantially completed by October 19, 2020. Substantial completion is the stage of completion where the project is fit for occupancy and use without hindrance for its intended purpose.

Project shall be fully completed and ready for final payment in accordance with the date specified in the agreement.

PART 2 - PRODUCTS

Not Applicable

PART 3 - EXECUTION

Not Applicable

END OF SECTION

SECTION 01330
COLOR AUDIO-VIDEO SURVEY
OF CONSTRUCTION AREAS

PART 1 - GENERAL

1.01 Work Included

The Contractor shall perform an audio-video survey of the project area to document the “pre-construction” conditions of the project and adjacent areas.

PART 2 - PRODUCTS

Not Applicable

PART 3 - EXECUTION

3.01 Preconstruction Documentation

- A. Contractor shall take a sufficient number of digital preconstruction photographs, minimum 100, so as to resolve any disputes, which may arise regarding the considerations prior to and subsequent to construction.
- B. Contractor shall furnish one USB flash drive of the digital preconstruction photographs to the Engineer, and shall make others available for review in settling any disputes.
- C. In addition to photographs, the Contractor shall produce a high-quality preconstruction video of the entire site on a USP flash drive and submit it to the Engineer.
- D. If a dispute arises where digital preconstruction photographs or video was not taken, the disputed area shall be restored to the extent directed by the Engineer and to the complete satisfaction of the Engineer.

END OF SECTION

SECTION 01340
SUBMITTAL PROCEDURES

PART 1 - GENERAL

1.01 Work Included

- A. This section includes procedures for preparing and transmitting submittals required by specification sections for a product, material, or construction method. Submittals shall include the following:
 - 1. Shop drawings
 - 2. Product data
 - 3. Manufacturer's certificates
 - 4. Design data and calculations
 - 5. Manufacturer's instructions
 - 6. Manufacturer's field service reports
 - 7. Samples
 - 8. Operation and maintenance manuals (timing, quantity, content, and form)
- B. It is the responsibility of the General Contractor to convey the requirements of this section to their sub-contractors and their suppliers and vendors.

1.02 Submittals

- A. Schedule submittals to expedite work. Unless otherwise indicated in this section, submittals shall be submitted within 30 days of date of Notice to Proceed.
- B. Preparation
 - 1. Provide separate submittals for each specification section requiring submittals. Where multiple sections relate to the same system or element and are being provided from the same source, a single combined submittal is acceptable.
 - 2. Coordinate submission of related items. Group submittals of related products in a single transmission.
 - 3. Include all submittal material requested for that section.
 - 4. Identify variations from requirements of contract documents. State product and system limitations which may adversely affect work.
 - 5. Mark or show dimensions and values in same units as specified.
- C. Contractor Responsibilities
 - 1. Review submittals prior to transmittal. Verify compatibility with field conditions and dimensions, product selections and designations, quantities, and conformance of submittal with requirements of contract documents. Return non-conforming submittals to preparer for revision, rather than submitting for review.

2. Coordinate submittals to avoid conflicts between various items of work.
3. Submittal Transmittal Form
 - a. Include with each submittal a transmittal form. A sample copy of an acceptable form is included in Attachment A. The Contractor's standard submittal form may be used, provided it contains essentially the same information as the sample.
 - b. Identify project, Contractor, subcontractor, supplier, manufacturer, pertinent drawing sheet and detail numbers, and associated specification section numbers.
 - c. Sequentially number transmittal forms. Re-submittals shall have original number with a suffix. Acceptable form of number is SS SS SS-NN-T where:
 - i. SS SS SS indicates specification section number;
 - ii. NN indicates different submittals for that specification section; and
 - iii. T indicates the number of times that submittal has been made.
4. Failure of the Contractor to review submittals, prior to transmittal for review, shall be cause for rejection.
5. Incomplete, improperly packaged, and submittals from sources other than the Contractor will not be accepted.

D. Transmittal

Where possible, transmit all submittals electronically. Where electronic submittal is not possible, submit four paper copies for the Engineer's retention, plus as many copies as the Contractor desires returned after review. Samples shall be submitted as described elsewhere in this specification.

E. Review

The Engineer will review and return submittals with comments.

F. Do not fabricate products or begin work which requires submittals until return of reviewed submittal with A/E or SNL SE acceptance.

G. On return, promptly distribute reviewed submittals to concerned parties. Instruct parties to promptly report any inability to comply with provisions.

H. Resubmission

1. Revise and resubmit submittals, as required, within 15 days of return from initial review.
2. Make re-submittals under procedures specified for initial submittals.
3. Identify all changes made since previous submittal.

1.03 Quality Assurance and Quality Control

A. Where required by specification sections, provide quality assurance submittals:

1. Qualification Data

Contractor shall submit written information demonstrating capabilities and experience of firm or person. Include lists of complete projects with names and contact information for references.

2. Manufacturer's Certificates

Submit reference data, affidavits, and certifications on manufacturer's letterhead certifying that products conform to or exceed specified requirements. Certificates may be based on recent or previous test results supplied by manufacturer and accepted by the Engineer.

3. Installer Approval

Certification on manufacturer's letterhead that installer complies with requirements and is approved for installing manufacturer's products.

4. Field Test Reports

Written reports from qualified testing agency indicating and interpreting results of field tests performed either during or after installation for compliance with specified requirements.

1.04 Submittal Review

A. The Engineer will review submittals for the sole purpose of verifying general conformance with design intent and general compliance with contract documents. Approval of submittal by the Engineer does not relieve the Contractor of responsibility for correcting errors which may exist in submittal, or from meeting requirements of contract documents.

B. Review Time

Initial review will be performed within 14 days of receipt. Reviewer reserves the right to withhold action on a submittal requiring review of related submittals, until related submittal is received. Additional time will be required if processing must be delayed to permit review of related subsequent submittals. The Engineer will review re-submittals within 14 days.

C. Review Actions

After review, submittals will be returned and marked as follows to indicate action taken:

1. Reviewed, No Comments

Part of work covered by submittal may proceed, provided it complies with requirements of contract documents. Final acceptance will depend upon that compliance.

2. Reviewed, With Comments

Part of work covered by submittal may proceed, provided it complies with notations and corrections on submittal and requirements of contract documents. Final acceptance will depend upon that compliance.

3. Revise and Resubmit

Do not proceed with part of work covered by submittal including purchasing, fabricating, and delivering. Revise or prepare new submittal in accordance with notations and resubmit.

1.05 Drawings

A. Where required by specifications or otherwise needed, prepare drawings illustrating portion of work for use in fabricating, interfacing with other work, and installing products. Contract drawings shall not be reproduced and submitted as shop drawings.

B. When construction is complete, prepare and submit red-lined copies of the contract drawings showing clearly how construction deviated from the design, along with the authority for the deviation or change.

C. Electronic Format

1. Size printable to: 8½ inches by 11 inches minimum and 24 inches by 36 inches maximum.
2. Present in a clear and thorough manner. Title each drawing with project name. Identify each element of drawing with reference number.
3. Plans, elevations, sections, and detail shop drawings shall be to scale, with scale indicated.
4. Indicate field verified dimensions. Show relationship of products to adjacent work. Note coordination requirements.
5. Schematics and diagrams shall be logically arranged and presented in a clear, understandable manner with all items labeled.
6. Internal wiring diagrams: Provide internal wiring and elementary ladder diagrams for factory pre-wired equipment.
7. Control diagrams: Show relative positions of each component as a system diagram.

1.06 Product Data

- A. Provide product data such as manufacturer's brochures, catalog pages, illustrations, diagrams, tables, performance charts, and other material which describe appearance, size, attributes, code and standard compliance, ratings, and other product characteristics.
- B. Form
 1. Provide all critical information such as reference standards, performance characteristics, capacities, power requirements, wiring and piping diagrams, controls, component parts, finishes, dimensions, and required clearances.
 2. Submit only data which are pertinent. Mark each copy of manufacturer's standard printed data to identify products, models, options, and other data pertinent to project.
 3. Modify manufacturer's standard schematic drawings and diagrams and supplement standard data to provide specific information applicable to project. Delete information not applicable.
 4. Colors and Patterns: Unless color and pattern is specified for product, submit accurate color and pattern charts or samples illustrating manufacturer's full range for selection by the Engineer. Submit two hard copies only.

1.07 Design Data and Calculations

- A. Where required by specification sections, provide basic calculations, analyses, and data to support design decisions and demonstrate compliance with specified requirements. State assumptions and define parameters. Give general formulas and references. Provide sketches, as required, to illustrate design method and application.
- B. Arrange calculations and data in a logical manner, with suitable text to explain procedures and order.
- C. Indicate name, title, and telephone number of individual performing design and include professional seal of designer where applicable or required.

1.08 Manufacturer's Instructions

- A. Where required by specification sections, provide manufacturer's instructions for activities such as delivery, storage, assembly, installation, wiring, start-up, adjusting, and finishing.
- B. Indicate pertinent portions and identify conflicts between manufacturer's instructions and contract documents.
- C. Where appropriate, include preparation procedures; service connection requirements; critical ambient conditions; foundation requirements; special precautions; adjustment requirements; alignment procedures; leveling; purging; charging; lubrication; and cleaning prior to operation and/or Owner's acceptance.
- D. Installation (e.g., assembly, mounting, or wiring) and start-up instructions shall be submitted and available for review in the field prior to scheduled material or equipment installation.

1.09 Samples

- A. Submit samples to illustrate functional and aesthetic characteristics of products with all integral parts and attachment devices. Include full range of manufacturer's standard finishes, indicating colors, textures, and patterns for Engineer selection.
- B. Submission
Submit the number of samples specified in individual specification sections. One sample will be retained by the Engineer.
- C. Label with identification related to submittal transmittal form.

1.10 Manufacturer's Field Service Reports

- A. When an individual specification section requires services of manufacturer's field representative, submit report of observations, site decisions, and instructions given to installers.
- B. Form
 - 1. Present complete information in clear concise manner.
 - 2. Bind with titled cover in folder or binder.
- C. Report shall include:
 - 1. Time, location, conditions, and duration of activity;
 - 2. Names of persons performing and witnessing activity;
 - 3. Equipment used;
 - 4. Description of activity, data recorded, and results;
 - 5. Deficiencies found, corrective measures, and results of retesting; and
 - 6. Other pertinent data.
- D. Submit report within 30 days of construction site service visit.

1.11 Operation and Maintenance Data

- A. Where required by specification sections, provide operation and maintenance manuals.

PART 2 - PRODUCTS

Not Applicable

PART 3 - EXECUTION

Not Applicable

END OF SECTION

ATTACHMENT A - SAMPLE SUBMITTAL TRANSMITTAL FORM

Attachment A

SAMPLE SUBMITTAL TRANSMITTAL FORM

PROJECT: _____
CONTRACT NUMBER: _____
SUBMITTAL NUMBER: _____ RESUBMITTAL: YES NO
DATE: _____ NUMBER OF COPIES SUBMITTED: _____
SUBMITTAL DESCRIPTION: _____

RELATED DESIGN DISCIPLINE (circle):

Civil	Landscape	Architectural	Structural
Mechanical	Electrical	Telecommunications	Security
Fire Protection	Controls	Other: _____	

ASSOCIATED SPECIFICATION SECTION NO: _____

REFERENCED DRAWING SHEET NO: _____

SUBCONTRACTOR/SUPPLIER/MANUFACTURER PROVIDING SUBMITTAL DATA:

Name: _____
Address: _____
Telephone Number: _____

CONTRACTOR:

Name: _____
Address: _____
Telephone Number: _____

CONTRACTOR'S CERTIFICATION:

The undersigned, as representative of the Contractor for the above project, submits the following and certifies that:

1. Submittal has been reviewed and it is complete and conforms to requirements of contract documents, except as noted.
2. Required dimensions have been field verified and are acceptable for installation of proposed products and construction of proposed work.
3. Required quantities for products and materials covered by this submittal have been verified as correct.
4. Fabrication processes and construction methods proposed in this submittal are acceptable for this project and will result in a complete, functional installation.
5. Submittal has been coordinated with other submittals and work and proposed products and construction will properly interface with other construction.

NAME OF CONTRACTOR REVIEWER: _____

SIGNATURE OF CONTRACTOR REVIEWER: _____

DATE: _____

SECTION 01500
CONSTRUCTION FACILITIES AND TEMPORARY CONTROLS

PART 1 - GENERAL

1.01 Work Included

This work includes providing temporary facilities and controls during the construction of the project.

PART 2 - PRODUCTS

Not Applicable

PART 3 - EXECUTION

3.01 Electricity

Electricity for use by the Contractor during the construction of the project will be provided by the Owner. The Contractor shall provide such temporary systems necessary to convey the electricity to the work area from the point of supply.

Temporary power supply systems shall comply with all applicable codes.

3.02 Lighting

The Contractor shall provide lighting for construction activities. The Contractor shall provide fixtures, switches, conductors, and other equipment for a complete system. The lighting system shall meet the requirements of all applicable codes.

Electricity for lighting will be paid for as described in Section 3.01.

3.03 Heat, Ventilation

The Contractor shall provide supplemental heat and ventilation, as required, to maintain specified conditions for construction operations and to protect materials, equipment, and finishes from damage due to temperature or humidity.

The Contractor shall provide ventilation of enclosed areas to cure materials, to disperse humidity, and to prevent accumulations of dust, fumes, vapors, or gases.

The Contractor shall provide ventilation of enclosed areas, as necessary, to maintain safe working areas as required by applicable codes.

3.04 Water

The Owner will provide water for construction activities, at the location of existing water lines, faucets, and hydrants. The Contractor shall provide such piping extensions, as necessary, to deliver the water to the location(s) required for construction activities.

3.05 Barriers

The Contractor shall provide barriers to prevent entry to construction areas or hazardous areas.

3.06 Enclosures

The Contractor shall provide temporary weather tight enclosures of openings in exterior surfaces to provide acceptable working conditions, protection of materials from the elements, and to prevent entry of unauthorized persons.

3.07 Protection of Installed Work

The Contractor shall control vehicle and pedestrian traffic and/or provide temporary protective coverings, as required, to protect installed or uncompleted work from damage.

3.08 Cleaning

The Contractor shall maintain the construction area free of debris and waste material. Debris and waste material resulting from construction operations shall be properly disposed of by the Contractor.

The Contractor shall clean areas, as required, for proper execution of the project work.

3.09 Drinking Water

The Contractor shall furnish drinking water for their workers.

3.10 Sanitary Facilities

The Contractor shall provide sanitary facilities for their workers as required by laws and regulations. The Contractor shall service and clean the facilities.

END OF SECTION

SECTION 01600
MATERIALS AND EQUIPMENT

PART 1 - GENERAL

1.01 Work Included

Unless specifically indicated otherwise on the plans or in the contract documents, all materials and equipment shall be new and undamaged.

A. Materials and Equipment

1. Materials and equipment incorporated into the work shall conform to applicable specifications and standards. Materials and equipment shall comply with size, make, type, and quality specified or as specifically approved by the Engineer.
2. Manufactured and fabricated products shall be designed, fabricated, and assembled in accordance with the best engineering and shop practices. Like parts of duplicate units are to be manufactured to standard sizes and gauges to be interchangeable. Two or more items of the same kind shall be identical and manufactured by the same manufacturer. Products shall be suitable for the service conditions. Equipment capacities, sizes, and dimensions shown or specified shall be adhered to unless variations are specifically approved in writing. Materials or equipment shall not be used for any purpose other than that for which it is designed or specified.

1.02 Substitutions

- A. Where specific materials and equipment items are identified in the specifications by manufacturer's name or model number, bids shall be based on the products of one of the manufacturers so named or added thereto by addendum during the bidding period.
- B. During the bidding period, all requests for substitutions will be given full consideration by the Engineer; and if approved, an addendum will be issued to incorporate the approved material or equipment into the contract documents.
- C. Requests for substitutions must be received by the Engineer in ample time, not later than ten days before the bid due date, so that any necessary addendum will be received by all prospective bidders before submission of the bids.
- D. After award of the contract, requests for substitutions will be considered only for one of the following reasons:
 1. Increased value to the Owner
 2. Decreased cost to the Owner
 3. Specified items not procurable
- E. Requests for substitutions after award of the contract shall be accompanied by manufacturer's data or other detailed descriptions of the proposed material or equipment.
- F. A request for a substitution constitutes a representation that the Contractor has investigated and determined the proposed product is equal to or superior in all respects to that specified.

- G. The Contractor shall coordinate the installation of an accepted substitution into the project to provide a complete and operable system. Modifications or re-work of other parts of the project resulting because of substitutes will be at the Contractor's expense.
- H. The Engineer shall be the judge of the acceptability of the proposed substitutions.

1.03 Manufacturer's Instructions

- A. When contract documents require that installation of work shall comply with the manufacturer's printed instructions, the Contractor shall obtain and distribute copies of such instructions to the parties involved in the installation, including two sets to the Engineer. The instructions shall be provided in advance of installation. The Contractor shall notify the Engineer in the event job conditions or the requirements of the plans or specifications conflict with the manufacturer's instructions.
- B. The Contractor shall handle, install, connect, clean, condition, and adjust products in accordance with such instructions and in conformity with the specified requirements.
- C. The Contractor shall perform work in accordance with manufacturer's instructions. No preparatory step or installation procedures shall be omitted unless specifically modified or exempted by contract documents.

PART 2 - PRODUCTS

Not Applicable

PART 3 - EXECUTION

3.01 Transportation and Handling

- A. The Contractor shall arrange deliveries of products in accordance with construction schedules and coordinate them to avoid conflict with work and conditions at the site.
 - 1. Products shall be delivered in undamaged condition, in the manufacturer's original containers or packaging with identifying labels intact and legible.
 - 2. Immediately upon delivery, the Contractor shall inspect shipments to assure compliance with requirements of contract documents and approved submittals and that products are properly protected and undamaged.
- B. The Contractor shall provide equipment and personnel to handle products by methods to prevent soiling or damage to products or packaging.

3.02 Storage and Protection

- A. Products shall be stored in accordance with the manufacturer's instructions, with seals and labels intact and legible.
 - 1. Products subject to damage by the elements shall be stored in weather tight enclosures.
 - 2. Temperature and humidity shall be maintained within the ranges required by manufacturer's instructions.

- B. The Contractor shall arrange storage in a manner to provide easy access for inspection and make periodic inspections to assure that products are maintained under specified conditions and free from damage or deterioration.
- C. For products specified by naming one or more products or manufacturers and "or equal", the Contractor must submit a request for substitutions for any product or manufacturer not specifically named.

END OF SECTION

SECTION 01710
CLEANING

PART 1 - GENERAL

1.01 Work Included

Throughout the construction period, the Contractor shall maintain the buildings and site in a standard of cleanliness as described in this section.

1.02 Quality Assurance and Quality Control

The Contractor shall conduct daily inspections, and more often if necessary, to verify that the standards of cleanliness are being met.

The project area shall be maintained in compliance with pertinent requirements of governmental agencies having jurisdiction.

PART 2 - PRODUCTS

2.01 Cleaning Materials and Equipment

The Contractor shall provide all required personnel, equipment and materials needed to maintain the required standard of cleanliness. Only cleaning materials and equipment which are compatible with the surface being cleaned, as recommended by the manufacturer, shall be used.

PART 3 - EXECUTION

3.01 Progress Cleaning

The Contractor shall retain all stored items in an orderly arrangement allowing maximum access, not impeding drainage or traffic, and providing the required protection of the materials. The Contractor shall not allow the accumulation of scrap, debris, waste material, and other items not required for construction of the project.

At least biweekly, and more often when necessary, the Contractor shall completely remove all scrap, debris, and waste material from the project site. Items to be removed shall be properly stored in accordance with fire codes and environmental regulations.

The Contractor shall inspect the project site daily, more often when necessary, and pick up all scrap, debris, and waste material. All such items shall be placed in the area(s) designated for their storage.

The site shall be maintained in a neat and orderly condition at all times.

Weekly, and more often if necessary, all interior surfaces shall be swept clean. "Clean" shall be interpreted for this purpose as free of dust and other material capable of being removed by use of reasonable effort and handheld broom.

As required, preparatory to installation of succeeding materials, the Contractor shall clean the structures or pertinent portions thereof to the degree of cleanliness recommended by the

manufacturer of the succeeding material, using the required equipment and materials to achieve the required cleanliness.

Following the installation of finish floor materials, the Contractor shall clean the finish floor daily (and more often if necessary) at all times while work is being performed in the space in which the finish materials have been installed. "Clean" for this purpose is interpreted as meaning free of foreign material which, in the opinion of the Engineer, may be injurious to the finish floor material.

3.02 Final Cleaning

Prior to completion of the work, the Contractor shall remove all tools, surplus materials, equipment, scrap, debris, and waste from the job site.

Exterior pavement areas shall be broomed clean. The resulting debris shall be completely removed. No debris or dust will be within the pool shell; the basin and adjacent surfaces will be 'swim ready' for filling and operation.

The Contractor shall visually inspect all exterior structure surfaces and remove all traces of soil, waste material, smudges, and other foreign matter. All traces of splashed materials on adjacent surfaces shall be removed. If necessary to achieve a uniform degree of cleanliness, the entire surface of the exterior of the structure shall be hosed down and cleaned. In the event that stubborn stains are not removable with water, the Engineer may require light sandblasting or other cleaning at no additional cost to the Owner.

The Contractor shall inspect all interior surfaces and remove all traces of soils, waste material, smudges, and other foreign matter. Remove all traces of splashed materials from adjacent surfaces. The Contractor shall remove all paint droppings, spots, stains, and dirt from finished surfaces. Only cleaning materials and equipment specified for use on the surfaces to be cleaned shall be used.

The Contractor shall clean glass, inside and outside surfaces.

The Contractor shall polish and buff metal fixtures and accessories. The polish shall be as recommended by the manufacturer of the items being polished.

The final cleaning shall be scheduled as approved by the Engineer to enable the Owner to accept a completely clean project.

3.03 Cleaning During Owner's Occupancy

Where the Owner occupies a portion of the project, the portion being occupied shall be cleaned as provided for final cleaning. Once the area is accepted by the Owner, future cleaning will be the Owner's responsibility.

END OF SECTION

707.01

Section 707. STRUCTURAL STEEL CONSTRUCTION

707.01. Description. This work consists of fabricating, shop cleaning and coating, providing, delivering, and erecting structural steel and other materials.

A. Steel Fabrication Requirements. American Institute of Steel Construction (AISC) certification is required for the steel fabrication work listed below.

1. Category Simple Steel Bridges (Sbr) for un-spliced rolled beams or other bridge related components including but not limited to pin and hanger assemblies, excluding machining operations; diaphragms, cross-frames, and connection angles and plates.
2. Category Major Steel Bridges (Cbr) for welded plate girders.
3. Fracture Critical Members Endorsement in addition to Category Major Steel Bridges for fracture critical members.
4. Sophisticated Paint Endorsement for painted steel surface areas greater than 500 square feet. The Engineer will accept Society of Protective Coatings, SSPC QP3 Shop Painting Certification Program as an acceptable alternate.
5. Category Bridge and Highway Metal Components when fabricating bridge tube railing, bearing assemblies (including pot and disc bearings), modular bridge expansion joints, sidewalk and deck grating (welded only), and miscellaneous steel components permanently attached to the structure as determined by the Engineer

B. Welding Requirements. Weld in accordance with AWS D1.5, Bridge Welding Code, as modified by this section. The Engineer will consider rolled beams, cover plates, flange and web plates, link bars, end diaphragms, and end diaphragm connection plates and stiffeners as primary members. For horizontally curved girders the Engineer will consider intermediate cross frames and connection plates and stiffeners as primary members.

C. Shop Cleaning and Coating. Shop clean and coat in accordance with section 716.

707.02. Materials. Provide material in accordance with the following:

Structural Steel	<u>906</u>
High Strength Steel Bolts, Nuts and Washers.....	<u>906</u>
Pins.....	<u>906</u>
Shear Developers.....	<u>906</u>
Miscellaneous Metals	<u>908</u>
Elastomeric Bearings.....	<u>914</u>

Non-Metallic Washers914

Provide bushings with a nominal wall thickness of ¼ inch, selected from the Qualified Products List.

Provide steel castings unless cast iron or other material is required or approved by the Engineer in writing.

Provide the Engineer with one copy of Mill Test Reports, from the manufacturer's records, of chemical composition and physical properties of structural steel members. Provide an affidavit stating that the material meets specifications. If Mill Test Reports are unavailable, arrange for tests of chemical and physical properties and provide two certified copies of the test reports and affidavits to the Engineer, at no additional cost to the Department.

For materials not requiring Mill Test Reports, provide two copies of an affidavit stating that the material meets the specifications, to the Engineer.

Identify each test report and affidavit with the relevant Department structure number and the specific structure members to which the test reports or affidavits apply.

707.03. Construction.

A. **Shop Inspection.** The Department will provide shop inspection for structural steel, castings, and similar materials. The fabricator must establish and maintain effective quality control procedures. The Department inspection is not a substitute for fabricator quality control procedures.

1. **Notice of Beginning of Work.** Give two weeks notice to the Engineer before beginning work in the shop.

If the fabricator suspends work for a period in which the Inspector leaves the shop, provide two weeks notice, or a period, agreed upon in advance with the Engineer and fabricator, before restarting work.

2. **Facilities for Inspection.** Provide facilities for inspection of material and workmanship, at no additional cost to the Department. Include a desk, locker, plan rack, secure storage space for testing equipment, high-speed broadband internet service, and a telephone. Allow the Inspector access to parts of the shop relating to the work.

Provide an office close to the work with at least 120 square feet of floor space, lighted, heated or air conditioned, ventilated, and shared by no more than one other Inspector. The Engineer may approve sharing larger offices with additional Inspectors. Provide equipment

707.03

in the office in working order. Provide a parking space for the Inspector next to the office.

3. **Shop Inspector's Authority.** The Inspector has the authority to reject material or construction that does not meet the contract requirements. The Inspector may suspend the use of equipment or an operation that does not produce desired results, until the fabricator takes corrective action. If problems arise that the Inspector cannot resolve, conduct a three-way conversation between the Engineer, the Inspector, and the fabricator.

The Inspector will report final decisions back to the fabricator.

4. **Rejections.** The Engineer may reject finished members at the project site that the Inspector approved at the shop for material and workmanship. Correct or replace damaged or defective material or workmanship at no additional cost to the Department.

B. Prefabrication Meeting. Do not begin fabrication work until the Engineer and the fabricator conduct a prefabrication meeting at the fabricating plant. Verify the date of the prefabrication meeting. The prefabrication meeting must include the Engineer, other Department representatives, and the fabricator's representatives directly responsible for supervision and control of the work. Finalize procedures relating to shop fabrication of the material included in the contract and the proposed schedule of fabrication and delivery at the prefabrication meeting.

C. Furnishing and Fabricating.

1. **Shop Plans.** Prepare working drawings of fabrication details in accordance with subsection 104.02. Do not use design drawings in lieu of shop plans. Submit one set of drawings and one electronic file copy to the Engineer for review and approval. After the Engineer approves the working drawings, provide the Engineer one complete sets of prints, one electronic file copy, and three sets of shop bills. After fabrication is complete, provide the Engineer one complete set of working drawings in ink on white, 3-mil polyester/Mylar drafting film, 24 inches by 36 inches and an electronic file copy. Include changes from the time the Engineer approved the original drawings.

2. Welded Plate Girders and Rolled Beam Fabrication.

- a. **General.** Show, on the working drawings, the procedure for each type and size of welded joint or bolted connection.

Weld the plates that comprise the flange and web of the girders into a single plate before welding flanges and webs together to form individual girders or box girders.

Use the automatic Submerged Arc Welding (SAW) process to make flange and web butt welds, to connect the flanges to the webs, to attach cover plates to beam flanges, and to attach stiffener and connection plates to webs, including flange-to-web welds in box girders, arches, towers, and truss web and chord members.

Use flat (1F) or horizontal (2F) positions for flange-to-web and cover plate-to-flange fillet welding. Limit the use of the Shielded Metal Arc Welding (SMAW) process to welding stiffeners or connection plates to rolled beams, stiffener-to-flange welding on plate girders, and welding bearing assemblies. Use SMAW for other welding applications if the limited access, isolated locations, or short weld lengths render the use of automatic or semi-automatic welding equipment impractical. Use E7018 electrodes for the SMAW process.

Do not use electroslag or electrogas welding processes.

Remove weld metal splatter on adjacent base metal, as approved by the Engineer, before blast cleaning and coating.

Determine fillet weld size by the thicker of the two parts joined, unless the calculated stress requires a larger size. The Engineer does not require exceeding the thickness of the thinner part joined with fillet welds. If the weld size is smaller than the minimum required due to plate thickness, preheat to ensure weld soundness. Provide a minimum $\frac{5}{16}$ inch fillet weld for a flange weld. Provide the minimum fillet weld sizes specified in Table 707-1 and Table 707-2.

Base Metal Thickness of Thicker Part Joined (in)	Minimum Size of Fillet Weld (in)
$\leq \frac{3}{4}$	$\frac{1}{4}$
$> \frac{3}{4} - 1\frac{1}{2}$	$\frac{5}{16}$
$> 1\frac{1}{2} - 2\frac{1}{4}$	$\frac{3}{8}$
$> 2\frac{1}{4} - 6$	$\frac{1}{2}$
> 6	$\frac{5}{8}$

Table 707-2 Minimum Effective Weld Size for Partial Joint Penetration Groove Welds	
Based Metal Thickness of Thicker Part Joined (in)	Minimum Effective Weld Size (a) (in)
$\leq \frac{3}{4}$	$\frac{1}{4}$
$> \frac{3}{4} - 1\frac{1}{2}$	$\frac{5}{16}$
$> 1\frac{1}{2} - 2\frac{1}{4}$	$\frac{3}{8}$
$> 2\frac{1}{4} - 6$	$\frac{1}{2}$
> 6	$\frac{5}{8}$
a. Except the effective throat need not exceed the thickness of the thinner part.	

- b. **Lifting Methods.** If using lifting lugs, weld them to the upper flange in areas subjected to compression. Submit the proposed details and design calculations to the Engineer for approval before fabricating. Conduct nondestructive testing on the welds connecting lifting lugs to the girder, as directed by the Engineer. Note on shop drawings if lugs will lift one piece, or will lift assemblies of two pieces or more.

Immediately after erecting the steel girder, remove lifting lugs by cutting and grind the area smooth.

Provide lifting devices with softeners to prevent damage. If using hooks for lifting, provide jaw and throat widths large enough to prevent damage. Provide spreader beams or multiple cranes for lifting plates and long slender members to prevent overstress and distortion.

3. **Straightening.** Straighten material in accordance with the tolerances in AWS D1.5, Bridge Welding Code, Section 3.5, before laying or working the material. Obtain the Engineer's approval for straightening methods. The Engineer may reject material with kinks or bends.

Straighten flanges joined by butt welds before fitting to the webs. Remove distortion, due to welding or handling, by applying heat over the full width of the flange. Do not heat to greater than 1,200 °F. Cool slowly. Complete straightening before testing in accordance with subsection 707.03.C.9.

4. **Cambering.** Accomplish cambering, camber adjustment, and horizontal curvature by heat in accordance with Section 11.4.12, Curved Girders, of AASHTO LRFD Bridge Construction Specifications. Provide dimensional tolerances in accordance with AWS D1.5, Bridge Welding Code, Section 3.5.

During the heating process, verify the temperature using temperature monitoring devices.

Measure the camber of each member in the shop and with the Inspector present, as a condition for approval for shipment.

5. **Cutting and Planing.** Plane $\frac{1}{4}$ inch of metal from sheared edges of steel greater than $\frac{5}{8}$ inch thick and alloy steel greater than $\frac{1}{2}$ inch thick. Fillet a $\frac{3}{4}$ -inch radius on re-entrant angles.

If flame cutting flange and web plates, cut edges simultaneously.

At the time of cutting, transfer heat numbers to the pieces of primary member material cut from large plates. Mark with white paint that lasts through fabrication.

6. **Splices and Connections.**

- a. **Shop Splices.** The fabricator may splice girder web plates, unless prohibited by the contract.

Only splice flange plates in girders greater than 50 feet long.

If the Engineer approves, provide one splice per cover plate.

Obtain the Engineer's approval for the location of optional web and flange splices.

Separate girder flange plate and web plate butt welds, as well as stiffener and connection plate attachment welds, by at least one foot

- b. **Holes for High Strength Bolts.** Punching holes is limited to AASHTO M 270 Grade 36 steel no greater than $\frac{3}{4}$ -inch thick or high-strength steel no greater than $\frac{5}{8}$ inch thick. Provide a die with a diameter that does not exceed the diameter of the punch by more than $\frac{1}{16}$ inch for punching full-size. Provide a die that does not exceed the diameter of the punch by more than $\frac{3}{32}$ inch for sub-punching.

Sub-drill or sub-punch holes for primary member splices two sizes undersize and ream full size.

Drilling holes full size is permitted while working on the splice if all material is assembled as it will be used in the final joint assembly. When drilling assembled splices, pre-drilling one plate full-size for use as a template is acceptable.

Drilling holes full size with computer numerically controlled (CNC) equipment is permitted.

Match-mark all joints, which have been reamed or drilled, with the parts assembled. Partially assemble joints with plates attached so erecting crews do not misplace, interchange, or reverse joint parts. Match-mark in one location using low stress stamping. Show match-marking schemes on the shop drawings and obtain the Engineer's approval for mark locations.

For primary members, load carrying diaphragms, and load carrying cross-frame connections, drill finished holes $\frac{1}{16}$ inch larger than the nominal bolt diameters required. Ensure finished holes are clean cut, without torn, ragged, burred, or crimped edges. Make finished holes in other diaphragms and cross-frames no more than $\frac{3}{16}$ inch larger than the nominal bolt diameter. Do not use welding to fill or repair misplaced drilled or punched holes.

7. **Assembly.** Assemble field connections of primary members in the shop and ream sub-size holes to the size required. Assemble using full truss or girder assembly methods, unless otherwise required.

- a. **Full Truss or Girder Assembly.** Assemble members of each truss, arch rib, bent, tower face, continuous beam line, plate girder or rigid frame at one time.
- b. **Progressive Truss or Girder Assembly.** Assemble for each truss, arch ribs, bents, tower faces, continuous beam lines, plate girders, or rigid frame, at least three consecutive shop sections or members in at least three consecutive panels. For structures longer than 150 feet, assemble at least the number of panels associated with three consecutive chord lengths, but no less than 150 feet of panels.

Before removing a member from the rearward end, maintain the assembled length by adding at least one shop section or panel, or as many panels as associated with a chord length at the advancing end of the assembly.

- c. **Full Chord Assembly.** Assemble, with geometric angles at the joints, the full length of each chord of each truss or open spandrel arch, or each leg of each bent or tower. Ream field connection holes while the members are assembled. Ream the web member connections to steel templates set at geometric angular relation to the chord lines.

Ream field connection holes in web members to steel templates. Mill or scribe at least one end of each web member normal to the

longitudinal axis of the member. Position templates at both ends of the member from one milled end or scribed line.

- d. **Progressive Chord Assembly.** Assemble consecutive chord members as required for full chord assemblies and in the number and length required for progressive truss or girder assemblies.
- e. **Special Complete Structure Assembly.** Assemble the entire structure, including the floor system.

Before reaming, obtain the Engineer's approval of each assembly, including camber, alignment, accuracy of holes, and fit of milled joints. Maintain a gap no greater than $\frac{3}{8}$ inch between girder ends at bolted field splices.

Provide a camber diagram to the Engineer, showing the camber at each panel point of each truss, arch rib, continuous beam line, plate girder, or rigid frame. Show the camber measured in assembly on the camber diagram if shop assembly is full truss, girder, or special complete structure assembly. For other shop assembly methods, show calculated camber on the camber diagram.

Use bolts for assembly of the same diameter as bolts required for erection. Use pins for assembly of the same diameter as the hole and in sufficient number to ensure accuracy.

Ensure drifting done while assembling field connections does not enlarge holes or distort metal. Ream under size holes to admit bolts. Do not move assemblies while drilling a joint, nor disassemble until drilling or reaming is complete and the Inspector approves the holes and markings.

Ensure the Engineer approves tack welding temporary fitting aids during fabrication. Do not tack weld fitting aids to the flange.

- 8. **High Strength Steel Bolts.** If high strength steel bolts are required for connections, provide heavy hexagon structural bolts. Provide heavy, semi-finished, hexagonal nuts with one circular washer for each bolt. Lubricate galvanized nuts with a lubricant with a visible dye. Supply two washers for oversize holes, one under each element. Supply 5 percent more high strength steel bolts of each size and length than required.

707.03

9. **Welding.** Ensure shop welders, welding operators, welding equipment, and welding procedures are qualified in accordance with AWS D1.5, Bridge Welding Code, as modified by the contract.

Make test welds under the supervision of a Department representative. The Engineer will not accept weld tests by other agencies.

Shop welder and welding operator qualifications remain in effect for three years unless welders or welding operators are not engaged in a welding process for at least three months, or a specific reason exists to question the welder's ability. The Engineer may require a confirming qualification test during the progress of the work. The Department considers welders and welding operators, qualified on Grade 50 high-strength steel, qualified to weld Grade 36 steel if the shop qualifies the procedure as required.

10. **Nondestructive Testing of Welds.** Nondestructive testing of welds is required. The fabricator must provide labor, equipment, and materials for making inspections. The Engineer will determine the adequacy of the equipment, materials, and procedures and witness testing.

Make required identification marks on butt welds with paint. Do not stencil or punch the marks.

Ensure technicians approved by the Department perform ultra-sonic testing.

- a. **Scope of Examination of Groove Welds.** Use radiographic test methods in accordance with AWS D1.5, Bridge Welding Code. Use ultrasonic test methods for examining full penetration corner joints and T-joints if radiographic testing is not possible. If the Engineer allows ultrasonic testing, use glycerine as the coupling agent. Test butt welds, or other full penetration welds in primary members as follows:
- i. Flange splices, 100 percent;
 - ii. Splices subject to reversal of stress, 100 percent;
 - iii. Web splices, beginning at the point of maximum tension, 12 inches, or at least $\frac{1}{3}$ the length plus 12 inches of the web splice beginning at the compression end, including splices connecting pin plates to webs;
 - iv. Compression and shear splices in built-up members, 25 percent;
 - v. Flange to web connections of box girders, 25 percent, unless otherwise shown on the plans;

- vi. Similar welds in a member subject to partial examination if the Engineer finds a defect in the member welds, 100 percent;
- vii. Butt weld repairs requiring weld defect removal and replacement, 100 percent; and
- viii. Ultrasonically tested plug and slot welds, 100 percent.

For thickness transition joints, place radiographic film on both sides of the joint, position the pack, and use tapered edge blocks. If substandard images result from film placement on transition sides, move the film to the planar side.

Submit for the Engineer's approval, a proposed procedure for ultrasonic testing of corner joints or joints with backup bars.

Complete radiographic or ultrasonic tests on groove welds and obtain written approval before assembling and welding the flange plates and web plates to form girders.

Check full penetration butt welds on both ends for surface defects using dye penetrant inspection, in accordance with ASTM E 165. Inspection is mandatory for welds inspected by radiography or ultrasonic testing.

Use extension blocks to extend radiographic film at least 1 inch beyond the edges of the radiographed section.

If using ultrasonic testing, perform radiography on one out of four welds. The Engineer may waive this requirement if the welders demonstrate and maintain a high level of competence.

- b. **Scope of Examination of Fillet Welds.** Magnetic particle testing of fillet welds is required. Perform magnetic particle testing in accordance with ASTM E 709, using the yoke, or aluminum prod method. Use half-wave rectified alternating current (direct current) for magnetic particle testing.

Test fillet welds, including welds connecting bearings and intermediate stiffeners to girder tension flanges and sole plates welded to girders using the magnetic particle process. Do not test fillet welds connecting intermediate stiffeners to the girder web, diaphragm assemblies, sway bracing, and other secondary members.

Test stiffener end to tension flange welds over the entire length. Test other fillet welds on at least 10 percent of the length of every weld, or at least 10 inches, whichever is greater for each fillet weld size. Include all primary members such as girders;

707.03

floor beams; stringers; truss members including end connections; and bearing blocks and assemblies including their attachment to members.

Locate the tests randomly in members to produce results typical for each weld size. If test results show unacceptable defects, test the full length of the weld, or 5 feet on each side of the tested length, whichever is less.

- c. **Weld Condition.** Clean paint, scale, grease, and other deleterious material from welded edges and surfaces. Grind flange welds flush on aligned sides and merge smoothly on transition sides.

Maintain areas requiring automatic and semi-automatic welding at a temperature of at least 40 °F for at least 1 hour before beginning work. Maintain the temperature during work.

If conducting radiography testing, grind web, shear, or pin plate splices. Grind the length of the film on the film side of the web, and begin merging smoothly at ends beyond the film. Grind fascia beams on the inside of the girder.

Grind surfaces to a roughness rating of 125 micro inches per inch root mean square. Remove loose mill scale on joint sides ultrasonically tested to allow one bounce of the ultrasound with a 70-degree transducer. Remove glycerine with a solvent before welding or blast cleaning the steel.

- d. **Defective Welds.** Repair and replace welds with rejectable defects documented by Contractor personnel or Department personnel, regardless of testing method and regardless of conflicts in test results from other methods. Submit repair procedures in writing and obtain the Engineer's approval for the repair method of weld defects before beginning repairs.

Repair, or remove and replace welds in accordance with AWS Code. Retest repaired or replaced welds, including at least 3 inches on all sides of the repair, by non-destructive testing method.

Remove and replace the entire weld if second repair attempts do not succeed. If the Engineer determines defects, or repairs to defects excessive, or the same defect undergoes repair more than twice, the Engineer may reject the entire piece.

11. **Fit of Stiffeners.** Remove and correct stiffeners showing evidence of compressive stress after fitting is completed, including waviness along the stiffener length, before final welding.

12. **Pins and Link Plates.** The contract drawings show the nominal diameter of pins. The fabricator may establish the exact diameter of the pin, show it on the shop drawings within +0 inch and $-1/32$ inch of the nominal diameter and then fabricate the pin to within ± 0.005 inch.

Use stainless steel hanger pins. Finish the surface to less than 16 micro inches per inch, root mean square (rms) on the bearing surface, and less than 125 micro inches per inch rms on the ends.

Finish the surface on link plates to less than 125 micro inches per inch rms on cut edges and bored holes.

Orient the longitudinal axis of the link plates and pins in the direction of rolling or forging of plates or bars.

Do not weld on pins or link plates. Finish pin holes smooth, straight, at right angles to the axis of the member, and parallel to each other.

Do not exceed $1/32$ inch variation from the required distance from outside to outside of adjacent pin holes in tension members, or from inside to inside of adjacent pin holes in compression members. Bore built-up members after welding. Drill or bore link plates in a jig or in assembled pairs.

Drill or bore the pin hole in the web $1/32$ inch ± 0.005 inch, larger than the pin diameter.

13. **Bushings for Pins and Link Plates.** Prime the inside of the holes in the link plate with an organic zinc-rich primer before installing bushings. Install bushings before the primer dries. Install bushings with an interference fit of at least 0.001 inch. Provide a clearance from 0.005 inch to 0.015 inch between the inside diameter of the bushing and the finished diameter of the stainless steel pin.

14. **Bearings and Bearing Surfaces.** The Contractor may build up sole plates 3 inches thick, or greater, by welding together plates at least $1\frac{1}{2}$ inches thick.

Bevel plate edges $\frac{1}{4}$ inch and weld with a continuous weld along the full perimeter. Plane the top and bottom surfaces of column and pedestal base plates and cap plates or, if less than 4 inches thick, flatten by pressing. Face member parts, contacting column and pedestal base plates and cap plates, to fit.

707.03

Ensure sole plates on beams and plate girders fully contact flanges. Seal weld around sole plates. Plane, heat straighten, or flatten by pressing, sole plates and masonry plates. If planing is required on welded pedestals, complete the welding first. The Engineer does not require planing surfaces bearing on elastomeric bearing pads. Ensure planed or bored bearing surfaces meet the following roughness rating values:

- a. Bridge rockers, 250 micro inches per inch rms; and
- b. Pin holes and sliding bearings, 125 micro inches per inch rms,

Galvanize and apply the tie coat, intermediate coat, and top coat to steel material for bearings, except the portion welded to beams, after fabricating the bearing.

15. **Finished Members.** Provide finished members, true to the line shown on the plans, and free of twists, bends, and open joints.

Dull or flatten the corners of exposed steel edges by grinding or other Engineer-approved methods before shop cleaning.

Repair damage caused by handling, to the Engineer's satisfaction.

16. **Correction of Errors or Defects.** Obtain the Engineer's approval for the proposed method of correcting errors or defects in fabricated material, before beginning work. Perform corrections in a timely manner, unless the Engineer approves delaying the work until later fabrication stages.

Obtain written approval from the Engineer before beginning corrective work paid by the Department. Maintain an accurate record of the labor, equipment, and materials and present an itemized bill for approval by the Engineer. Correlate records daily with those kept by the Inspector.

17. **Galvanizing Structural Steel.** Hot-dip galvanize position dowels and anchor bolts, including nuts and washers, in accordance with AASHTO M 232. Tap oversized galvanized nuts in accordance with AASHTO M 291 or AASHTO M 292 and meet Supplementary Requirement S1 of AASHTO M 291 or AASHTO M 292. Remove excess hot-dip galvanizing on threaded portions by centrifuging or air blasting upon withdrawal. Do not flame-chase.

Before galvanizing, prepare steel components in accordance with SSPC-SP8 Pickling.

Galvanize portions of bearings not welded to the beam or girder, and other structural members and parts requiring galvanizing in

accordance with AASHTO M 111. Blast clean fabricated components to remove mill scale and welding slag before galvanizing.

If top coating galvanized surfaces, use the “dry process” during galvanizing. Do not quench galvanized components following galvanizing. Do not apply chromate surface passivation treatments to galvanized components requiring top coats.

18. **Handling and Storing Materials.** Store structural material on platforms, skids, or other supports above high water elevations. Maintain materials free of dirt, oil, or other contaminants and protect from corrosion. Pad structural members in storage at points of contact. Pitch trough sections to provide drainage. Support long members at frequent intervals to prevent deflection. Handle, store, and brace girders and beams in the erected position, unless otherwise authorized by the Engineer, and avoid distortion.

Protect fasteners from dirt and moisture on the project. Remove from protected storage, the number of fasteners required to be installed and tightened during a work shift. Return unused fasteners to protected storage at the end of shifts. Do not remove lubricant required for fasteners in the as-delivered condition. Clean, relubricate, and test fasteners for slip-critical connections that accumulate rust or dirt from site conditions, before installation.

Handle structural steel members and parts of primary member with clamps or plate hooks that do not leave nicks, gouges, or depressions. Repair damage to primary members using methods approved by the Engineer. Repair damage consistent with the delivery of structural steel in accordance with ASTM A 6, and AWS D 1.5, Bridge Welding Code, Section 3. Do not use chains or chokers for handling structural steel, unless placing a protective shield between the chain and the steel. Minimize handling stresses on beams and girders during transportation, storage, and erection. Use one-point pickup so overhang does not exceed the values specified in Table 707-3. Do not exceed the distances specified in Table 707-3 between hooks for two-point pickup.

Beam Size	30 inch WF	33 inch WF	36 inch WF	Plate Girders
Overhang for One-Point or 2-Point Pickup, Max	37 ft	40 ft	42 ft	50 ft
Distance Between Hooks for 2-Point Pickup, Max	74 ft	80 ft	85 ft	100 ft

19. **Marking and Shipping.** Provide the Department with copies of material orders and shipping statements, as directed by the Engineer. Show the weights of individual members on the statements. Mark weights on the member if greater than 6 tons.

If using low stress stamping equipment, the fabricator may stamp members if approved by the Engineer. Do not stamp link plates, pin plates, or pins. If stamping primary members, stamp before coating, in the top flange cross-sectional area or on the top of the compression flange, within 6 inches of the end. Show the match-marking scheme on the shop drawings. Markings must be legible after completion of the final coating system.

Load, transport, and unload structural members using trucks or railcars, without stressing, deforming, or otherwise damaging members. Place a protective shield between the chain or chain binder and primary members during shipping, to prevent gouging the flange edges or damaging the coating.

Pack bolts, loose nuts, and washers of each length, diameter, or size, separately. Store and ship pins, small parts, and packages of bolts, washers, and nuts in clean, moisture proof boxes, crates, kegs, or barrels. Limit the gross weight of each package to 300 pounds. Provide a list and description of contents on the outside of each shipping container.

D. Erection of Structural Steel.

1. **Methods and Equipment.** Before beginning work, obtain the Engineer's approval for proposed equipment and erection methods. Do not use material intended for the finished structure for erection or temporary purposes unless otherwise shown on the plans or approved by the Engineer.

The Engineer's approval does not relieve the Contractor of the responsibility for the safety of the method or equipment.

2. **Bearings.** Position column bases, truss and girder pedestals, shoes, and bearing plates with a full, uniform bearing on the substructure concrete. Adjust bearing plate and masonry plate locations and rocker positions to compensate for temperature at the time of erection.
3. **Falsework.** Build and remove falsework in accordance with subsection 706.03.C and subsection 706.03.O.
4. **Straightening and Repair of Damaged Material.** Straighten plates, angles, other shapes, and built-up members, with the Engineer's

approval, without producing cracks or other damage. Straighten distorted members by carefully planned and supervised application of limited localized heat. Do not exceed 1,200 °F on heated areas, as determined by temperature-indicating crayons, liquids, or bimetal thermometers. Do not apply mechanical forces for straightening.

Inspect the surface of the metal for damage after straightening. Perform nondestructive testing, as directed by the Engineer.

5. **Assembling Steel.** Assemble parts according to the plans and shop drawings. Do not damage steel during erection. Clean rust, loose mill scale, dirt, oil or grease, and other deleterious material from bearing surfaces and surfaces in permanent contact before assembly.

At the time of erection, coat machine finished surfaces with a commercial grade lubricant approved by the Engineer. Lubricate pedestal and rocker-to-sole plate surfaces and sliding metal-on-metal bearing surfaces.

Align all parts in splices and field connections before inserting connection bolts. The Engineer may direct filling at least 10 percent of each splice connection with temporary bolts to bring the plies of steel tight before installing permanent bolts. Install permanent bolts in remaining splice locations and commence turn-of-nut tightening of the permanent bolts in accordance with subsection 707.03.D.7.c. Remove temporary bolts and replace with permanent bolts. Tighten using turn-of-nut method.

In bolted connections, do not expose nuts in fascia girder outer faces or on the bottom faces of lower flanges.

If field splicing girders in the air, install $\frac{1}{3}$ of the bolts, evenly distributed over the connecting elements, and snug tighten before releasing lifting devices.

Tighten bolts in spans of continuous girders in accordance with subsection 707.03.D.7.c before casting deck concrete.

6. **Misfits.** Correct and replace misfits, errors, and damage at no additional cost to the Department. Obtain the Engineer's approval for correction methods. Do not force structural members into place.

The Engineer will witness correction methods.

7. **Bolted Connections.** Do not exceed a 1:20 slope on the surfaces of bolted parts in contact with bolt heads and nuts, with respect to a plane perpendicular to the bolt axis. Use beveled washers to

707.03

compensate for slopes greater than 1:20. Fit bolted parts solidly together and do not separate with compressible material.

During assembly, maintain joint surfaces free of mill scale, burrs, dirt, and other deleterious material. Use the same combinations of tested nut, bolt, and washer lots for field assembly as those tested and approved by the Engineer for use in combination.

- a. **Washers.** Install a hardened washer under the fastener element turned during tightening. Seat the element for turning during tightening against a non-sloping surface.

Use smooth beveled washers where necessary to compensate for the surface slope of bolted parts with respect to the bolt head or nut.

- b. **Bolt Tension.** Tighten each fastener in accordance with Table 707-4.

Tighten bolts using the turn-of-nut method in accordance with subsection 707.03.D.7.c. If required because of bolt entering and wrench operation clearances, tighten by turning the bolt while preventing the nut from rotating.

If using impact wrenches, provide wrenches sufficient to tighten each bolt in approximately 10 seconds. Perform verification testing, witnessed by the Engineer, on a representative sample of at least three bolt assemblies of each diameter, length, and heat or lot. Test at the beginning of work in a device that shows bolt tension. Show that the method for estimating the snug tight condition, and controlling the turns from snug tight, develops a tension of at least 5 percent greater than the tension specified in Table 707-4, when performed by the bolting crew. Perform periodic retesting if directed by the Engineer.

Bolt Size (in)	Minimum Bolt Tension (lb), (a)
1/2	12,050
5/8	19,200
3/4	28,400
7/8	39,250
1	51,500
1 1/8	56,450
1 1/4	71,700
1 3/8	85,450
1 1/2	104,000
a. Equal to 70% of specified minimum tensile strength of bolts.	

- c. **Turn-of-Nut Tightening.** Bring enough bolts to a snug tight condition to ensure parts of the joint fully contact. Snug tight is the tightness attained by a few impacts of an impact wrench, or the full effort of a person using an ordinary spud wrench. Place bolts in remaining holes in the connection and bring to snug tightness. Mark each bolt to reference the rotation required for tightening. Tighten all bolts in the joint by rotating the nut in accordance with Table 707-5. Tighten systematically from the most rigid part of the joint to the free edges. Ensure parts, not turned by the wrench, do not rotate during tightening operations.

Do not reuse AASHTO M 164 bolts and nuts. The Engineer will not consider re-snugging previously tightened bolts loosened by the tightening of adjacent bolts, as reuse.

Table 707-5 Nut Rotation from Snug Tight Condition (a)			
Disposition of Outer Faces of Bolted Parts			
Bolt Length (b)	Two Normal (c)	One Normal One Sloped (c, d)	Two Sloped Faces (c, d)
≤4D	120°+30°	180°+30°	240°+45°
>4D – 8D	180°+30°	240°+45°	300°+45°
>8D – 12D	240°+45°	300°+45°	360°+45°
>12D	No data; determine required rotation by tests simulating actual conditions		
a. Nut rotation is relative to bolt, regardless of the element (nut or bolt) being turned. b. Measured from underside of head to extreme end of point. "D" is nominal bolt diameter. c. Relative to bolt axis. d. Sloped face not more than 1:20; no bevel washer.			

- d. **Inspection.** The Engineer will determine if bolts meet the requirements for bolt tension. Provide the Engineer with the opportunity to witness the bolt snugging, marking for final rotation, and tightening.
8. **Field Welding.** Do not field weld unless otherwise shown on the plans or approved by the Engineer. Obtain Engineer's approval for welding procedures before beginning field welding. Perform field welding and nondestructive testing in accordance with AWS D1.5, Bridge Welding Code.

Perform structural field welding by the SMAW process using E7018 electrodes. Do not use Gas Metal Arc Welding (GMAW), or other gas shielded processes. The Engineer may approve SAW and Flux Cored Arc Welding (FCAW) for field welding.

707.03

- a. **Qualification.** For welder qualification, test field welders. The Engineer will witness testing. The Engineer will not accept welder tests by other agencies. Perform welder qualification tests in accordance with AWS D1.5, Part B, Section 5, in the same position required for field welding, as determined by the Engineer. Field welder qualifications remain in effect for two years, unless the welder does not engage in welding for at least three months, or a specific reason exists to question the welder's ability.

For procedure qualification, do not perform field welding until preparation of written welding procedures, as established by testing. Perform weld procedure tests in the same position and joint configuration required for the field welding. The Engineer will approve the written welding procedures after completion of successful weld testing. Test in accordance with AWS D1.5, Section 5. Perform tests on the same steel plate material type for welding, and provide mill certification.

- b. **Welding Requirements.** Blast clean or grind contact surfaces, joints, and surrounding area before field welding. Remove loose mill scale, paint, galvanizing, grease, oil, rust, moisture, and other deleterious material from base metal before welding. Grind joints before field welding to remove pitting and irregularities. Prepare joints and remove deleterious material in accordance with AWS D1.5, Section 3.

Bring parts into close contact. If the separation between parts exceeds $\frac{1}{16}$ inch, increase the legs of the fillet weld by the separation distance. Do not weld if the separation between parts exceeds $\frac{3}{16}$ inch.

Transition weld profiles by grinding stop-start areas or other irregularities.

Do not perform field welding if the ambient air temperature falls below 40 °F or during periods of precipitation, unless heating and housing the area as approved by the Engineer.

Dry electrodes in an oven at a temperature of at least 500 °F for at least 2 hours before use. Store the electrodes at a temperature of at least 250 °F after drying. Use electrodes within 2 hours of exposure to the atmosphere, or redry. Do not redry electrodes more than once. Do not use electrodes that have been wet.

Preheat surfaces for welding 3 inches in every direction from the weld. Before welding, preheat surfaces to at least 250 °F for base metal no greater than 1½ inches thick. For base metals from 1½ inches thick to 2½ inches thick, preheat to at least 300 °F. If welding on plates greater than 2½ inches thick, preheat to at least 400 °F.

- c. **Inspection.** The Engineer will verify that the nondestructive testing, including visual inspection has been performed in accordance with, and the welds are acceptable according to, AWS D1.5. The Contractor is responsible for nondestructive testing of field welds. Blast clean or grind welds before conducting nondestructive testing. Use liquid dye penetrant or magnetic particle testing for fillet and partial penetration butt welds. Use ultrasonic testing for complete penetration butt welds, plug welds, and slot welds.

Perform nondestructive testing in accordance with subsection 707.03.C.10 and AWS D1.5. The Engineer will determine the frequency, location, and type of nondestructive testing. Personnel qualified as Level II or Level III in accordance with the American Society for Nondestructive Testing (ASNT), Recommended Practice No. SNT-TC-1A must perform all tests. Ensure an AWS Certified Weld Inspector (CWI) inspects all welds. Ensure testing personnel provide certifications to the Engineer before beginning the work. The Engineer will witness nondestructive testing.

Repair cracked welds, or welds the Engineer determines are unacceptable. Repair welds in accordance with AWS D1.5, Section 3.7. Inspect and test repaired welds before the Engineer's acceptance. Repair and retest welds at no additional cost to the Department.

- d. **Welding Piles or Falsework.** Agencies approved by the Department may perform welder qualification tests for welding piles or falsework. Structural welding or welding repair work requires Department qualification testing.

Ensure field welders present a certificate documenting qualification within the previous two years in accordance with the Department's Welder Certification by Agency program. Conform welding to AWS D1.1. The Engineer may require a confirming qualification test during the progress of the work.

707.03

- e. **Welding for Form Supports and Accessories.** If no other methods exist, the Engineer may allow welding to primary steel members. Prepare and submit to the Engineer for written approval, a detailed plan of operations if welding to primary steel members is anticipated. If the Engineer allows, weld to steel beams in compression areas only.

Ensure the field welder presents a certificate documenting qualification within the previous two years in accordance with the Department's Welder Certification by Agency program. Conform welding to AWS D1.1.

- f. **Shear Developers.** Do not weld if the temperature falls below 32 °F or if the surface is wet or exposed to rain or snow.

Remove rust, mill scale, paint, and galvanizing from the base metal at the stud location by grinding. Clean the stud end. End weld stud shear connectors to steel beams or girders with automatically timed stud welding equipment. When using automatically timed stud welding equipment, do not preheat the top of the beam flange. Perform and test stud welding in accordance with AWS D1.5, Bridge Welding Code.

Repair studs without a full 360-degree fillet weld by adding a 5/16-inch fillet weld to replace missing welds.

707.04. Measurement and Payment.

Pay Item	Pay Unit
Structural Steel, Rolled Shape, Furn and Fab.....	Pound
Structural Steel, Rolled Shape, Erect.....	Pound
Structural Steel, Plate, Furn and Fab.....	Pound
Structural Steel, Plate, Erect.....	Pound
Structural Steel, Mixed, Furn and Fab.....	Pound
Structural Steel, Mixed, Erect.....	Pound
Bearing, Elastomeric, __ inch.....	Square Inch
Shear Developers (Structure No.).....	Lump Sum
Bushing.....	Each

- A. **Structural Steel.** The Engineer will measure structural steel by the calculated weight of metal in the finished structure, excluding filler metal in welding, as shown on shop plans or working drawings. The Engineer will calculate the weight using the rules and assumptions specified in this subsection.

Unless otherwise required, the following metal weights apply:

1. Steel — 0.2833 pound per cubic inch;

2. Cast iron — 0.26 pound per cubic inch;
3. Bronze — 0.315 pound per cubic inch; and
4. Lead — 0.411 pound per cubic inch.

The Engineer will calculate the weights of rolled shapes and plates incorporated in the finished work on the basis of nominal weights and dimensions, as shown on the approved shop drawings, deducting for copes, cuts, and holes, except those for high strength bolts.

The Engineer will include the total calculated weight of bolts, nuts, and washers in the finished work in the weight of structural steel.

The Engineer will calculate the weight of castings from the dimensions shown on the approved shop drawings with an addition of 10 percent for fillets and overrun.

The Engineer will not make allowance for galvanizing, optional splices, lifting lugs, shop coating, or excess bolts in the calculated weight.

The Engineer will not include the weight of lifting lugs in the calculated weight for structural steel. The unit prices for structural steel pay items include the cost of providing, welding, and removing the lugs.

B. Welding. The Department will not pay for welding and nondestructive testing required for new, retrofitting, repairing, rehabilitation, or replacing structural steel components, including shop fabrication and field welding.

The Department will not pay for welding and submittal of qualification specimen costs, including nondestructive testing of weld specimens by radiography or ultrasonic testing and confirming test specimens. The Department will cut, machine, and test specimens without charge, except the Contractor is responsible for the cost of testing additional specimens if the first test specimens fail.

C. Structural Steel Plants. The Department will not allow additional compensation for costs incurred in the certification of structural steel plants, or claims by the Contractor for delays and inconvenience attributed to certification requirements.

D. General. The unit prices for **Structural Steel, Erect** pay items include the cost of installing and removing temporary bolts as directed by the Engineer. The unit price for **Structural Steel, Erect** pay items include the cost of field drilling.

The unit prices for **Structural Steel, Furn and Fab** pay items include the cost of shop cleaning and coating the steel.

707.04

The Engineer will measure **Bearing, Elastomeric**, of the size required, by area, with no deductions for holes. The unit price for **Bearing, Elastomeric** includes the cost of steel laminates bonded to the elastomeric bearing.

The Engineer will measure **Shear Developers** as a unit for each structure. The unit price for **Shear Developers** includes the cost of providing studs, cleaning the surface by grinding, and welding studs to the girder flanges.

The unit price for **Bushing** includes the cost of priming the inside holes in the link plate and providing and installing the bushing.

The cost of supplying, installing, and removing temporary bolts at splice connections when this work is required by subsection 707.03.D, is included in the unit price for relevant pay items.

713.01

Section 713. BRIDGE REHABILITATION — STEEL

713.01. Description. This work consists of repairing and replacing portions of structural steel bridges.

A “redundant structure” consists of supporting elements that provide an alternate stress path if one element fails or is taken out of service; the loss of supporting elements in a “nonredundant” structure will cause failure of the complete structure.

713.02. Materials. Provide materials in accordance with the following:

Concrete, Grade S2.....	<u>701</u>
Steel Reinforcement, Grade 60.....	<u>905</u>
Structural Steel.....	<u>906</u>
High Strength Bolts, Galvanized A 325.....	<u>906</u>
Structural Timber and Lumber.....	<u>912</u>

A. Steel for Temporary Supports. Provide temporary hanger rods that meet the requirements of ASTM A 193 Grade B7 (AISI 4140). Provide rods with longitudinal Charpy V-notch impact values of 50 foot-pounds at 30 °F. If necessary, heat treat steel to meet the Charpy V-notch impact requirements. The Engineer will reject rods with notches, nicks, or welds.

Provide a sample 15 inches long, saw cut from each bar length used for hanger rod fabrication. Provide adequate notice to allow a Department representative to witness the removal of samples from each bar length. The Department will use these samples for tensile strength, yield strength, and impact testing. Reduce the sample length to 8 inches, for impact testing only, if providing a Certified Mill Test Report, traceable to the material. Match-mark each bar sample and corresponding remainder, by stenciling in the end cross-section.

The Engineer will base rod material acceptance on Department testing and traceable Certified Mill Test Reports.

Provide heavy hex nuts for the temporary hanger rods in accordance with ASTM A 563 Grade DH or ASTM A 194 Grade 2H, and washers in accordance with ASTM F 436.

Provide steel for temporary supports in accordance with AASHTO M 270 Grade 36 and section 906.

B. Sealant for Perimeter of Beam Plates. Select the sealant from the Qualified Products List. Provide sealant in caulking tubes.

713.03. Construction.

A. Providing and Fabricating Structural Steel. Provide and fabricate structural steel additions and replacements for existing structures and steel portions of temporary supports in accordance with section 707. Submit shop drawings to the Engineer for approval before fabrication.

Measure the pin dimensions of existing link plates from center-to-center. If pin dimensions differ by more than $\frac{1}{8}$ inch from the dimensions shown on the plans, build replacement link plates to existing dimensions instead of plan dimensions. The Engineer will direct changes to plan dimensions to fit existing dimensions.

Submit to the Engineer, a final report on the pin and hanger assemblies that lists the as-built dimensions of the new link plates and pins. Demonstrate that tolerances meet the requirements specified in subsection 707.03.C.12. Install bushings in accordance with subsection 707.03.C.13. Assemble and ship pin and link plate pairs as a unit or match mark pairs.

B. Temporary Supports for Girder Ends. Use plan drawings, or propose an alternate design and obtain the Engineer's approval, for temporary supports for girder ends. Base alternate designs on loads and allowable soil pressures shown on the plans. Include calculations for alternate designs in the alternate design submittal. Ensure alternate designs maintain redundancy and material safety factors specified in AASHTO LFRD Bridge Design Specifications. Ensure a professional engineer, licensed in the state of Michigan seals alternate designs.

The Department reserves the right to verify structural adequacy of fabricated temporary support systems used. Verification may include visual inspection and nondestructive testing by Department personnel. The Department may require mill test report submittals for material and shop drawings of original fabrication. Before using temporary supports, make corrections deemed necessary by the Department.

Provide hydraulic jacks with a stroke of at least 3 inches and pumps capable of extending jacks full stroke. Equip hydraulic systems with dial gauges that enable determination of the external loads.

Provide hydraulic jacks with locking rings or other positive locking devices to prevent settlement in case of hydraulic failure. Use locking devices during and after jacking cycles until placement of stable shims and removal of loads from jacks.

Maintain temporary support, including replacing supports in case of partial or complete failure. The Department reserves the right to provide

713.03

labor, materials, and supervision to restore movement of traffic if the Contractor delays or makes inadequate progress in the repair or replacement of a temporary support, at no additional cost to the Department.

1. **Column-Type Supports.** After erection, before loading temporary supports, use a plumb line to determine the horizontal offset of the top of the column from the bottom of the column. Determine the horizontal offset of the hydraulic jack from the column centerline. Measure the column and hydraulic jack offsets parallel and perpendicular to the column web. Place jacks and temporary supports at each location so individual offsets and the sum, in each measured direction, do not exceed 1 inch. Consider jack offsets positive, regardless of column offset directions.

If structure embankment (CIP) is not required by the contract, compact the natural ground 9 inches deep, to at least 95 percent maximum unit weight before placing temporary supports.

If placing temporary supports on paved shoulders or roadways, place a leveling course of 21AA aggregate, asphaltic cold-patch, or other material approved by the Engineer. Compact leveling material to 95 percent maximum unit weight before placing temporary supports.

The Engineer may direct bracing of temporary supports, based on Contractor methods for performing rehabilitation work.

Leave jacks in place until installation and operation of link plates and pins. The Contractor may disconnect lines and pumps provided the equipment remains on the project.

During the first 4 hours after loading, check hourly for settlement of temporary supports. Make subsequent settlement checks daily. To prevent girder ends from subsiding more than $\frac{1}{16}$ inch from the original position, correct by adding shims to temporary supports.

2. **Suspension-Type Supports.** After placing stable shims, the Engineer may approve removing jacks.

Repair concrete removed for erecting temporary support or access to the girder end, as approved by the Engineer.

3. **Diaphragm-Type Supports.** Place temporary supports on substructure units as shown on the plans. Equally load and simultaneously advance hydraulic jacks placed in pairs.

Leave jacks in place until repair or replacement and operation of structural components. The Contractor may disconnect lines and pumps provided the equipment remains on the project.

Propose grouting material and placement procedures to the Engineer for approval. Place grout on substructure units to create a smooth and level bearing surface for temporary supports. Select an H-1 grout material in accordance with section 702. Form the space for grouting and clean the surface. Mix, place, and cure grout material in accordance with the manufacturer's recommendations. After curing, remove forming material to allow the Engineer to inspect the grouted space. Do not apply load to grout until the grout attains a minimum compressive strength of 4,000 psi.

C. Pin and Hanger Replacement.

1. **Measurement of Existing Hanger Assemblies.** Take field measurements of hanger assemblies requiring replacement and submit as-built dimensions, and a drawing showing the measured span and girder end, to the Engineer.

Measure existing pin diameters, the distance between pins from center-to-center, and the length, width, and thickness of link plates.

Check girder web alignment by laying a straight edge across pin plate gaps at the top and bottom of the girder. Measure and report girder offsets.

Close lanes or shoulders to allow field measurements in accordance with the Michigan Manual of Uniform Traffic Control Devices and the contract documents. Obtain the Engineer's approval for lane and shoulder closures. Do not leave lanes or shoulders closed overnight for field measurements.

2. **Removal of Existing Hanger Assemblies.** Remove existing hanger assemblies as shown on the plans and in accordance with subsection 204.03.A.5 and this subsection.

If removing and replacing link plates and pins from more than one girder at a time, do not work on the same end of adjacent girders. Ensure suspenders remain operational on the girder end opposite removed link plates or pins.

Support girder ends on stable shims, without using hydraulics, before removing components. Remove two pins and two link plates in each assembly. Cut the link plates and pins for removal in accordance with the following:

713.03

- a. Cut link plates into two pieces with a sloping transverse cut that coincides with the joint opening between girder ends. If cutting link plates at the pin, position a sheet metal shield behind link plates to protect the girder.
 - b. Place a metal heat shield around pin holes before flame cutting pins. The Contractor may trim pin ends to within no less than 1 inch of girder pin plates. The Contractor may burn a hole through the center of pins to ease removal. If pin removal gouges a hole in girder pin plates, grind plates smooth before blast cleaning and coating. Obtain written approval from the Engineer for welding repair of girder pin plate holes.
3. **Installation and Coating of New Hanger Assemblies.** If end diaphragms prevent installation of new pins, flame cut an oblong hole in the web of one end diaphragm using as a cutting guide, at least a 1/8-inch thick steel hole template, clamped to the channel section. After flame cutting, grind hole edges to a surface roughness no greater than 125 micro-inches per inch root mean square (rms). Clean and coat holes and leave in the finished structure. Do not loosen or remove end diaphragms.

After removing pins, grind notches and deep pits in the girder pin plate around the periphery of the hole to a surface roughness no greater than 125 micro-inches per inch rms. Clean and coat girder ends, within 3 feet of each side of the centerline of pin holes or to the nearest stiffener, before installing new hanger assemblies. Clean and coat in accordance with section 715.

Assemble new hanger assemblies before removing falsework shims.

D. Bearing Stiffeners at Temporary Supports. Erect bearing stiffeners at temporary supports in accordance with section 707. Leave stiffeners in place as a permanent part of the structure. Field drill bolt holes in existing girders; do not flame cut or air arc gouge existing girders or proposed attachments. Complete field drilling before blast cleaning and prime coating faying surfaces.

Before erecting bearing stiffeners, clean and coat faying surfaces and other contact surfaces. Faying surfaces consist of surfaces internal to a connection that bear on an adjacent surface. Clean and coat faying surfaces and other contact surfaces in accordance with section 715.

After bolting bearing stiffeners in place, clean and coat exposed areas in accordance with section 715. The Contractor may perform this cleaning and coating immediately after erection or during cleaning and coating of the remainder of the girder.

E. Retrofit Structural Steel. Erect retrofit structural steel in accordance with subsection 707.03.D. Leave retrofit structural steel in place as a permanent part of the structure. Field drill bolt holes in existing steel; do not flame cut or air arc gouge the existing steel or attachments. Complete field drilling before blast cleaning and prime coating faying surfaces.

Before erecting retrofit structural steel, clean and coat faying surfaces and other contact surfaces. Clean and coat retrofit structural steel in accordance with section 715.

After bolting structural steel in place, clean and coat the exposed areas in accordance with section 715. The Contractor may perform this cleaning and coating immediately after erection or during cleaning and coating the remainder of the girder.

F. Sealing the Perimeter of Beam Plates. Before applying sealant, clean and dry surfaces between repair plates or angles and beams and other surfaces requiring sealant. Apply sealant around the perimeter of bolted or riveted plates or angles on steel beams, as directed by the Engineer. Apply sealant over the intermediate coat when dry to the touch.

Apply sealant when air and surface temperatures are above 40 °F. Immediately after applying sealant, tool to form a ⁵/₁₆-inch fillet and force it against contact surfaces. Completely fill pits and depressions in steel beams at the seam line with sealant, regardless of width and depth. Apply a top coat over sealant after the intermediate coat cures.

G. Heat Straightening Damaged Structural Steel. Heat straighten damaged structural steel under the direct on-site supervision of a specialist in heat straightening bridge structural steel. This specialist must submit written documentation of three years experience, on a continuous basis, with successfully heat straightening comparable steel structures.

Before beginning work, obtain the Engineer's approval for details of heat straightening types and methods. Notify the Engineer at least 48 hours before beginning the heat straightening work. Ensure final straightened members retain as little residual stress as possible.

If an area is exposed to precipitation, do not perform heat straightening unless the area is housed as approved by the Engineer. Apply heat at a temperature no greater than 1,200 °F and monitor with contact thermometers, pyrometric sticks, or other heat indicating devices approved by the Engineer. Supply heat indicating devices and make available to the inspector. Provide torch tips with a diameter from ³/₄ inch

713.03

to 1 inch. Heat all plastic yield zones and only plastic yield zones. Use line, strip, spot, and "V", triangular, heats. Do not use a "V" angle greater than 20 degrees. Limit the base of the "V" heat to 6 inches. Heat the "V" from the apex, in a serpentine pattern to the base so only the area directly under the torch shows color. Do not force cool. After each heat straightening cycle, allow steel to cool to below 250 °F before beginning the next heating cycle.

Straighten with as little mechanical force as possible. Use constraints that do not resist contraction during the cooling phase and that do not produce local buckling of compression elements during the heating phase.

Eliminate bends, creases, folds, and dents in web plates, flange plates, angles, stiffeners, channels, gusset plates, and torn areas.

Straighten the flange plates and angles to within ¼ inch of the tilt rotation at the edges from the web, with ½ inch of sweep over 20 feet, ¾ inch at the point of impact. Straighten the web to less than ½ inch out of plumb. Reduce localized deflections in the web to no greater than ½ inch, vertically and horizontally, measured with a straight edge.

Straighten webs to the required tolerances before attaching cross frames or other lateral restraint devices. Do not force beams and girders into position and attach to cross frames to hold in position.

Do not flame cut existing structural steel, except as shown on the plans.

Grind burrs, nicks, gouges, and scrapes to 125 micro-inches per inch rms and taper to the original surface using a 1:10 slope. Provide surface quality in accordance with ASTM A 6.

Report cracks or tears in beams and girders, or in other structural steel members not shown on the plans to the Engineer. The Engineer will direct the repair methods.

Inspect completed straightening for cracks in welds, web, flanges, plates, and connections. Repair cracks by welding in accordance with subsection 707.03.D.8. Provide adequate notice to allow the Engineer to witness the crack repair work. Inspect and test completed straightening and repaired cracks in accordance with subsection 707.03.D.8.c. Perform inspection and testing at no additional cost to the Department.

H. **Rocker Realignment.** Realign tilted rockers as shown on the plans and specified in this subsection. Coordinate the rocker realignment sequencing with proposed bridge repairs as shown on the plans and approved by the Engineer.

If realigning rockers of more than one girder at a time, do not work on the same ends of adjacent girders.

Do not jack existing girder ends more than $\frac{1}{8}$ inch above final rocker position.

Before removing rockers from girders, support girder ends on stable shims without using hydraulics.

Grind existing sole plate welds; do not flame cut or air arc gouge existing welds except as shown on the plans and approved by the Engineer.

Before welding sole plates in final position, clean and prime coat faying surfaces and other contact surfaces. Clean and coat faying surfaces and other contact surfaces in accordance with section 715.

Position sole plates with rockers to provide the correct rocker tilt using rocker tilt tables shown on the plans and approved by the Engineer.

Field weld existing sole plates to girder flanges in accordance with subsection 707.03.D.8. Inspect and test field welds in accordance with subsection 707.03.D.8.c.

I. **Cutting Simple Span Beam Ends.** Coordinate sequencing of beam end cutting with proposed bridge repairs, as shown on the plans and approved by the Engineer.

At each location, use a plasma cutting torch to cut no greater than $\frac{1}{2}$ inch off each beam end to provide vertical beam ends 1 inch apart. Use a straight edge or guide to provide horizontal and vertical control during cutting of beam flanges and webs. Mark cut lines on existing beams to verify cutting operations do not damage existing sole plates and bearing stiffener welds.

Do not damage or remove welds on sole plates or bearing stiffeners. Replace damaged welds. Field weld in accordance with subsection 707.03.D.8 and inspect and test in accordance with subsection 707.03.D.8.c.

Grind burrs, nicks, gouges, and scrapes to 125 micro-inches per inch rms on cut edges.

After cutting beam ends and completing field welding, clean and prime coat exposed areas in accordance with section 715.

J. **Structural Steel Welded Repair.** Erect structural steel components in accordance with subsection 707.03.D. Remove damaged or deteriorated structural components and replace with proposed structural components as shown on the plans and specified in section 204.

713.03

The Contractor may remove structural steel using mechanical methods, plasma cutting, or air-arc gouging.

Do not flame cut existing structural steel except as shown on the plans.

Prepare existing structural steel to accept proposed structural components and for field welding. Preparation may include field drilling coping holes and grinding, as shown on the plans.

Field weld in accordance with subsection 707.03.D.8. Inspect and test field welds in accordance with subsection 707.03.D.8.c.

After welding structural steel in place, blast clean and prime coat exposed areas in accordance with section 715.

The Contractor may perform cleaning and coating immediately after erection of structural steel components, or during cleaning and coating of the remainder of the girder.

713.04. Measurement and Payment.

Pay Item	Pay Unit
Structural Steel, Furn and Fab, Pin and Hanger	Pound
Hanger Assembly, Field Measurement	Each
Hanger Assembly, Rem and Erect	Each
Heat Straightening Steel (Structure No.).....	Lump Sum
Stiffeners, Furn, Fab, and Erect	Pound
Structural Steel, Retrofit, Furn, Fab, and Erect	Pound
Support, Column, Temp	Each
Support, Suspension, Temp	Each
Support, Diaphragm, Temp	Each
Beam Plate, Seal Perimeter	Foot
Rocker, Realign	Each
Cutting Beam Ends, Simple Span	Each
Structural Steel, Welded Repair, Furn, Fab, and Erect.....	Pound

A. **Hanger Assembly.** The unit price for **Hanger Assembly, Field Measurement** includes the cost of taking and recording measurements, maintaining traffic during measuring, and providing the Engineer with a location drawing showing the span and girder end where measurements were taken.

The unit price for **Hanger Assembly, Rem and Erect** includes the cost of the following:

1. Removing two pins, two link plates, and shear locks;
2. Blast cleaning and applying and curing coating in joint areas;
3. Installing two new link plates and two new pins;

4. Protecting completed joint areas with enclosures, if required; and
5. Protecting newly painted areas adjacent to joint areas.

The unit price for **Structural Steel, Furn and Fab, Pin and Hanger** includes the cost of structural steel required for pins and plates in rehabilitation work. The Engineer will measure steel as specified in subsection 707.04 for structural steel, furnish and fabricate pay items.

The Engineer will measure, and the Department will pay for structural steel required for pins and plates in new construction as specified in subsection 707.04 for structural steel, furnish and fabricate pay items.

The Engineer will measure, and the Department will pay for **Bushing** as specified in subsection 707.04.

B. Heat Straightening Steel. The unit price for **Heat Straightening Steel** includes the cost of attaining the required structural steel position, field welding, and nondestructive testing in accordance with subsection 707.03.D.8. The Department will pay for crack repair not shown on the plans as extra work.

C. Stiffeners, Furnish, Fabricate, and Erect. The unit price for **Stiffeners, Furn, Fab, and Erect** includes the cost of field drilling, installing bearing stiffeners on existing steel, and blast cleaning and prime coating contact surfaces.

The Engineer will measure structural steel for stiffeners as specified in subsection 707.04 for structural steel, furnish and fabricate pay items.

D. Structural Steel, Retrofit, Furnish, Fabricate, and Erect. The unit price for **Structural Steel, Retrofit, Furn, Fab, and Erect** includes the cost of field drilling, installing new structural steel on existing steel, and blast cleaning and prime coating faying and other contact surfaces.

The Engineer will measure structural steel required for retrofit as specified in subsection 707.04 for structural steel, furnish and fabricate pay items.

E. Support, Temporary. The unit price for **Support, Temp**, of the type required, includes the cost of providing, placing, maintaining, and removing materials and equipment, and concrete removal and replacement to access temporary supports. The quantity of **Support, Temp**, of the type required, indicates the number of girder ends requiring support; not the number of temporary support devices required.

F. Rocker, Realignment. The unit price for **Rocker, Realign** includes the cost of removing existing welds, determining correct rocker tilt, field welding, inspecting and performing nondestructive testing in accordance

713.04

with subsection 707.03.D.8, and blast cleaning and prime coating faying and other contact surfaces.

G. Cutting Beam Ends, Simple Span. The unit price for **Cutting Beam Ends, Simple Span** includes the cost of cutting existing beam ends, field welding, and performing nondestructive testing in accordance with subsection 707.03.D.8, blast cleaning and prime coating exposed steel, and completing the work for cutting two simple span beam ends at one location.

H. Structural Steel, Welded Repair, Furnish, Fabricate, and Erect. The unit price for **Structural Steel, Welded Repair, Furn, Fab, and Erect** includes the cost of removing, disposing, and replacing damaged or deteriorated structural steel components as shown on the plans, field drilling, field welding, nondestructive testing in accordance with subsection 707.03.D.8, and blast cleaning and prime coating structural steel components.

The Engineer will measure structural steel required for welded repair as specified in subsection 707.04 for structural steel, furnish and fabricate pay items.

**Section 715. CLEANING AND COATING EXISTING STRUCTURAL
STEEL**

715.01. Description. This work consists of cleaning and coating metal surfaces of existing steel structures, and containing, storing, and disposing of spent material. Spent material includes paint chips, abrasive particles, dust, and debris, resulting from cleaning operations. Metal surfaces of existing steel structures include downspouts, sign supports, and brackets; but do not include railings, chain link fencing, utility conduits, and associated brackets and hangers.

715.02. Materials. Provide materials in accordance with the following:

Epoxy Grout.....	<u>914</u>
Bridge Coating System.....	<u>915</u>

Use a Department-approved low dusting abrasive, steel grit or shot, or a combination of these, for blast cleaning. Select low dusting abrasive from the Qualified Products List.

Use a tie coat recommended by the coating manufacturer for galvanized surfaces.

715.03. Construction. Do not field coat from October 1 to May 1 in Superior and North Regions, or from October 15 to April 15 in the remaining regions unless otherwise approved by the Engineer. Comply with temperature restrictions specified in section 915.

Refer to SSPC *Steel Structures Painting Manual*, Volume 1 and Volume 2 for definitions of cleaning criteria and other coating terms.

Provide and erect scaffolding to allow inspection of steel before and after coating. Erect scaffolding to prevent damage to the structure and comply with MIOSHA rules.

Obtain the Engineer's approval for rubber rollers, or other protective devices used on scaffold fasteners. Do not use metal rollers, clamps, or other fasteners that may mar or damage the steel or coating.

A. Protection of Work and Environment During Cleaning Operations.

1. **Training Program.** Provide a documented training program covering the handling and storage of hazardous waste. Provide a copy of this program to the Engineer before beginning cleaning operations and keep a copy at the project.
2. **Worker Training.** Train every employee involved in cleaning the bridge (i.e., generating waste); or cleanup, handling, and storage of

715.03

spent material. Provide training in the management of hazardous waste, as required by the Resource Conservation and Recovery Act 42 USC 6901 et. seq. and 40 CFR 265.16. Keep training records available at the project.

3. **Hazardous Waste Contingency Plan.** Develop a contingency plan for generating, handling, and storing hazardous waste in accordance with 40 CFR Part 265, Subpart C and Subpart D. Address containment and cleanup of accidental spills or releases to the environment. List an emergency coordinator and a telephone number to reach this person 24 hours a day, 7 days a week.

Submit a copy of the contingency plan to the Engineer and keep a copy at the project.

4. **Labeling of Spent Material Containers.** Provide and place the required labeling for hazardous waste storage containers. Label containers before using for hazardous waste storage, and list the date waste is first placed into each container. Make the labels visible without moving containers. The Engineer will provide the EPA generator number required by 1994 PA 451, Part 111, Hazardous Waste Management, and Rule R299.9306, (1), (b) and (c).
5. **Weekly Inspection Log.** If temporarily storing hazardous waste on the project, maintain an inspection log of the storage area and containers. Keep the log on-site and update weekly to document inspection and security of the storage area and containers in accordance with 40 CFR 265.174.
6. **On-Site Records.** Keep the following records on-site and available until blast cleaning is completed and spent material is removed from the job:
 - a. Hazardous waste training program,
 - b. Worker training records,
 - c. Hazardous waste contingency plan,
 - d. Weekly inspection log,
 - e. Waste characterization reports, and
 - f. Waste disposal manifests.

Keep the records near the hazardous waste storage area in a conspicuous location and make available for inspection and review.

The Contractor may place on-site records in a clearly marked, closed barrel, next to the stored hazardous waste.

7. **Storage in Gondolas, Roll-off Boxes, or Barrels.** Store spent material, hazardous or nonhazardous, at the bridge site, secured and protected from weather, accidental spills, or vandalism. Locate the storage containers on a gradually sloped, free draining area, not immediately next to a traffic lane, water course, or direct drainage ditch or structure. Do not place storage containers in standing water. The Engineer will review proposed storage areas before cleaning operations begin.

Keep waste containers closed and covered, except during addition or removal of spent material. Label each container as hazardous or nonhazardous material storage and include the accumulation start date, as required.

Follow the hazardous waste contingency plan and immediately clean up spent material that spills onto the ground while depositing into storage containers.

- a. **Gondolas or Roll-off Boxes.** Cover each gondola or roll-off box with a cover integral to the gondola or box and a continuous, water repellent tarpaulin. Use support ribs, or other means to prevent water from ponding on the tarpaulin.
 - b. **Barrels.** Seal barrels storing hazardous waste with bolt-locking rims. Elevate barrels on pallets and arrange in single or double rows, allowing access for inspection and viewing of the labels. Bind the rows of barrels together with rope, cable, or binding straps to prevent tipping over. Cover rows of barrels with waterproof tarpaulins, held in place in accordance with 40 CFR 264.175 (c) and 40 CFR 265, Subpart I; 1994 PA 451, Part 111, Hazardous Waste Management; and Rule R299.9306, (1), (e) and (f).
8. **Disposal of Spent Material.** Notify the Engineer of the intent to sample. Ensure that sampling is conducted by a SSPC Competent Person and is witnessed by the Engineer. Take separate samples of spent material collected and stored in waste containers, dust collected from bag house filters, and shower water. Prepare a chain of custody form for each sample. Ship samples, with their chain of custody forms, in a tamper proof container or bag sealed and witnessed by the Engineer, to a laboratory as approved by the Engineer for testing according to the Environmental Protection Agency, Toxicity Characteristic Leaching Procedure (TCLP).

Use test results to characterize the spent material, bag house dust, and shower water for disposal.

715.03

Return the chain of custody form with the test results to the Engineer. The Engineer may sample and test spent material, bag house dust, and shower water during the project.

Dispose of spent material and bag house dust characterized as hazardous waste at a licensed hazardous waste disposal facility. Dispose of spent material and bag house dust characterized as nonhazardous waste at an approved Type II landfill in accordance with 1994 PA 451, Part 115, Solid Waste Management.

Dispose of shower water characterized as a hazardous waste at a licensed hazardous waste disposal facility. Dispose of shower water characterized as nonhazardous as a liquid industrial waste at an approved licensed liquid industrial waste disposal facility in accordance with 1994 PA 451, Part 121, Liquid Industrial Wastes.

Provide copies of waste manifests and disposal receipts to the Engineer.

Dispose of spent material within 90 days from the date spent material is first placed in the container.

The Department may remove and dispose of hazardous and nonhazardous waste and back-charge the Contractor for the work if the Contractor is untimely in removing waste in accordance with 40 CFR 262; 1994 PA 451, Part 111, Hazardous Waste Management, and Rule R299.9306.

B. Containment Requirements.

1. **General Requirements.** Clean bridges using total enclosure. Protect pedestrians, vehicular and other traffic on or under the structure, and workers in accordance with subsection 104.07.B. Include a barrier system that protects against the following:

- a. Direct, or indirect blasting of vehicles, water vessels, and pedestrians;
- b. Abrasive material and debris falling on the traveled portions of the pavement or into waterways; and
- c. Abrasive material and debris spreading into areas where it may create a traffic hazard.

The Contractor is responsible for damage to vehicles, persons, property, or the environment in accordance with subsection 107.07.

Provide total containment of portions of the bridge during cleaning and vacuuming. Contain spent material resulting from cleaning

operations. Use tarpaulins or other Department-approved material to enclose portions of the structure undergoing cleaning. Use tarpaulins made of an airtight material, and secure tightly and continuously at the seams. Do not use burlap or open web materials. Extend the enclosure from the bottom of the deck to ground level or to the level of a solid work platform, and fasten to prevent lifting or opening by the wind. Clamp seams and laps on tarpaulins or sheeting together along the length of the seams or laps to prevent material or dust from escaping the enclosed area.

Use metal halide lighting in the enclosure to illuminate active work surfaces to at least 50 foot-candles.

Design the required enclosure and provide air flow and dust filtering equipment for the design. The Engineer will evaluate the performance of the design on its ability to prevent the visible release of spent material and to provide ventilation to ensure worker safety.

Maintain negative pressure inside the enclosure to prevent spent material from leaving the enclosure during cleaning. Maintain air flow through the enclosure to provide visibility and a safe working environment for blasting operators. Provide limited air intake openings in the enclosure during the operation of air moving equipment. Filter air exhausted from the enclosure through a portable truck mounted filtering system or dust collectors. Clean filters or dust collectors before delivery to the project and before removal from the project. Obtain the required state and local air quality and noise ordinance permits for operating air-filtering equipment at the bridge site. Do not discharge dust from the filter exhaust, dust collectors, or vacuum truck.

Place ground cloths under the enclosed area and extend at least 10 feet beyond the enclosure edges, but not into open traffic lanes. Provide ground cloths with sealed seams or laps. Collect spent material that settles on ground cloths from work platforms and enclosures.

If protective devices do not serve the intended purpose, suspend work until corrected. If the Engineer determines threatening weather conditions may cause a release of spent material into the surrounding environment, the Engineer will shut down cleaning operations and require immediate clean up of spent material in the enclosure.

715.03

Prevent the release of spent material from the tarpaulins and other components of the containment enclosure during relocation or removal. Mechanically clean or vacuum the dust contaminated portions before moving. Protect workers from exposure to lead-bearing dust during moving or removal work.

2. **Bridges Over Waterways.** For cleaning bridges over waterways, provide the following measures in addition to the requirements of subsection 715.03.B.1:
 - a. Provide a stable barge in the water directly under the area enclosed for cleaning. Size and secure the barge to provide freeboard and stability to preclude the possibility of capsizing or sinking. Evenly distribute equipment and material loads on the barge. Extend containment enclosures to the level of the barge and secure to prevent release of spent material into the waterway. Cover the surface of the barge with ground cloths to allow collection of spent material.
 - b. If impractical to use a barge, erect a temporary work platform under containment enclosures to collect spent material. Extend containment enclosures to the level of the temporary platform and secure to prevent release of spent material. Before installation, submit plans for the proposed work platform in writing, to the Engineer for review.
 - c. Stretch a floating boom across the waterway 200 feet from the bridge, on the downstream and down wind side of the bridge. Collect, store, and dispose of spent material that accumulates at the booms as specified for other waste generated by cleaning operations.
3. **Cleanup and Storage of Spent Material.** Clean spent material in the containment enclosure daily and before prolonged work stoppage. Clean ground cloths. Immediately clean spent material released outside the enclosure in accordance with the hazardous waste contingency plan.

Place spent material in storage containers.

C. **Cleaning Structures.** Shield and protect utility pipes and conduits not requiring cleaning and coating. Notify affected utility companies at least 48 hours before beginning blast cleaning operations. Shield or mask freshly coated surfaces, railings, galvanized fencing, appurtenances, and adjacent concrete, not requiring cleaning and coating. Wire brush coated surfaces damaged by blasting or, if visibly rusted, re-clean to a near-white or bare metal condition. Vacuum and re-prime wire brushed or blast cleaned surfaces.

Remove and dispose of loose concrete from the bottom of deck slabs, fascia, concrete diaphragms, and beam perimeters at dependent backwalls. If possible, remove concrete with hand-held, non-power tools.

Before cleaning, scrape surfaces to remove dirt or debris and remove oil or grease deposits in accordance with SSPC-SP 1, Solvent Cleaning. Clean surfaces to SSPC-SP 10, Near White Blast Cleaning or SSPC-SP 11 Power Tool Cleaning to Bare Metal. Grind fins, tears, slivers, and burred or sharp edges on steel members in accordance with SSPC-SP 11 bare metal finish.

The Contractor may use scaling hammers to remove heavy scale on existing structures, but not chipping hammers.

The Engineer will use the visual standard in accordance with SSPC-VIS 1, Guide and Reference Photographs for Steel Surfaces Prepared by Dry Abrasive Blast Cleaning, SSPC-SP 10, or SSPC-VIS 3, Guide and Reference Photographs for Steel Surfaces Prepared by Hand and Power Tool Cleaning, SSPC-SP 11 that corresponds to the initial rust condition, to determine steel cleanliness.

Provide a uniform blast profile from 1 mil to 2.8 mils, measured using extra coarse replica tape, except on A 588 structures. For A 588 structures, supply a non-blasted piece of A 588 steel at least 1 foot square and ¼ inch thick and clean it on the project, using the proposed cleaning procedures. Obtain the Engineer's approval for the resulting profile before continuing.

Remove abrasive and coating residue from steel surfaces with a commercial grade vacuum cleaner equipped with a brush-type cleaning tool, or by double blowing with partial vacuuming. If using the double blowing method, vacuum the top surfaces of structural steel, including flanges, longitudinal stiffeners, splice plates, and hangers after completing double blowing. Provide an air line for blowing steel clean with an inline water trap and air free of oil and water as it leaves the air line. Maintain the steel dust free and apply prime coat within 8 hours of cleaning.

D. Coating Structural Steel.

1. **Applying the Coating.** After the Engineer approves cleaned surfaces, spray apply the coatings using the manufacturer's recommended nozzles and pressures. Provide a dry film thickness of 4 mils to 10 mils for primer, 3.5 mils to 9 mils for intermediate, and at least 1 mil for the top coat. Vacuum accumulated dirt from primed

715.03

surfaces before applying subsequent coats. If the Engineer determines the surface unfit for further coating, scrub the surface with a commercial detergent, rinse with water, and allow to dry for at least 24 hours before continuing.

Recoat areas with less than the required minimum primer dry film thickness. Use a magnetic film thickness gauge to measure the dry film thickness. Calibrate the gauge with plastic shims, the same thickness as the minimum dry film thickness, placed on a smooth section of newly cleaned steel.

Apply the intermediate and top coat to provide complete coverage with uniform color and appearance. If the dry film thickness exceeds the maximum, sand the areas to below the maximum thickness and clean before applying subsequent coats.

If coating applications result in runs, bubbles, or sags, apply coating using multiple passes of the spray gun, and allow several minutes between each pass.

Brush out runs and sags immediately, or remove and recoat the surface. Repair bubbles, pinholes, craters, and other defects by sanding the area and applying coating.

Protect wet coating against damage from dust and other deleterious material.

Remove all dry spray by sanding.

Correct coating the Engineer determines unsatisfactory and unauthorized.

Clean galvanized components, including nuts, bolts, and washers, to SSPC-SP 1 condition, provide a tie coat, and coat with intermediate and top coats. Apply tie coat to the thickness recommended by the manufacturer.

The Contractor may brush on the tie coat.

2. **Coating Faying Surfaces and Connections.** Faying surfaces consist of surfaces internal to a connection that bears on adjacent surfaces.

Coat new connections, and disassembled connections in existing structures. Apply prime coat the same way and to the same thickness as on the adjacent structural steel. Mask faying surfaces during subsequent coating operations.

Coat slip critical connections in accordance with section 716.

Perform final vacuuming of the connection immediately before reassembly. If vacuuming does not remove accumulated dust and dirt, or the Engineer determines the surface unfit for bolting, clean the surface. Scrub the surface with a mild detergent solution, rinse with water, and allow it to dry before assembling connections. After assembling the connection, blast clean and coat exposed areas of the connection. Clean and coat immediately after erection, or when blast cleaning and coating the remainder of the structure.

3. **Cure Times for Coatings.** Cure coatings for the minimum cure times specified in subsection 915.04.A. Follow the manufacturer's recommended maximum cure time, except do not allow more than 21 calendar days between coat applications. If the maximum time between coats is exceeded, blast clean newly coated surfaces and recoat at no additional cost to the Department.
4. **Protection of Work and Environment During Coating Operations.** Protect portions of the structure, including superstructure, substructure, slope protection, and highway appurtenances from spatter and overspray of coating material. Shield utility pipes and conduits not requiring coating.

Protect pedestrian, vehicular, water vessels, and other traffic in accordance with subsection 104.07.B.

If protective devices do not serve the intended purpose, the Engineer may suspend work until the Contractor makes corrections.

5. **Stenciling Requirement.** When coating is complete, stencil the structure number, completion date (month and year), and coating type onto the structure. On A 588 steel structures, stencil "A 588" just above the completion date. For partial painting projects, stencil the letter P before the coating type.

Use black urethane spray paint and 4-inch numbers for stenciling.

Stencil the numbers on the outside of each fascia beam at the approaching end of the structure. Place markings at least 10 feet above ground or fill slope elevations and at least 10 feet from abutments.

If not completely coating the fascia beam, stencil the designation on the outside of each fascia beam on the approaching traffic side, in the lower right corner of the newly painted section. Place markings completely within the partial coating limits, at least 3 inches above the bottom flange and with the stenciling ending within 3 inches of the right edge of the newly painted area.

715.03

If these locations are inconsistent with the newly painted areas of the structure, the Engineer will designate the stencil location.

6. **Solvents.**

- a. **Solvent Reuse Determination Procedures.** Prepare a written Solvent Reuse Determination Procedure that complies with 1994 PA 451, Part 111, Hazardous Waste Management, and Rule R299.9202. Provide a copy of this procedure to the Engineer before performing field coating.

Include, in the Solvent Reuse Determination Procedures, at least the methods for determining if the solvent is reusable; applications for use of reusable solvent; and a statement of effectiveness of the reusable solvent in each application cited.

Include in the Solvent Reuse Determination Procedure documentation certification of agreement to:

- i. Maintain records regarding solvent reuse on a "Bridge Painting Solvent Tracking Log;"
 - ii. Handle the solvent in a manner consistent with the product status as either waste or reusable solvent;
 - iii. Reuse solvent within 1 year of the initial use; and
 - iv. Reclaim only solvent after reusing it.
- b. **General.** Determine during performance of the work and before leaving the bridge site, if solvents for cleaning and coating equipment are reusable or considered waste. Make the determination and document in accordance with Solvent Reuse Determination Procedures and the applicable federal, state, and local laws and regulations. Provide a copy of the written determination documentation to the Engineer before removing solvents from the project. Dispose of non-reusable waste solvent associated with the project.

Manage, label, contain, store, and ship solvent determined reusable in accordance with the applicable federal, state, and local laws and regulations. Provide certification (shipping paper) for reusable solvent transported from the bridge site. Manage, label, contain, store, ship, and dispose of solvent characterized as waste in accordance with the following:

- i. 1994 PA 451 Part 111, Hazardous Waste Management;
- ii. Subtitle C of the Federal Resource Conservation and Recovery Act of 1976, as amended (RCRA);
- iii. 1994 PA 451 Part 121, Liquid Industrial Waste; and

- iv. The administrative rules or regulations promulgated pursuant to these acts, and other applicable federal, state, and local laws and regulations.

E. Removal and Replacement of End Diaphragms. Before beginning the removal and replacement of end diaphragms, divert traffic on the bridge from the affected bay until shoring placement is complete. Place shoring to support the concrete deck during diaphragm removal. Disconnect each end diaphragm from connecting plates or angles by removing existing bolts or rivets.

Clean the diaphragm and portions of the structure inaccessible with the diaphragm in place. Apply the prime coat and allow to cure in accordance with the manufacturer's requirements for slip critical connections at 50 °F or higher. Mask faying surfaces and the top of the diaphragm top flange. Apply the intermediate coat.

After the intermediate coat is dry to the touch, coat the top of the diaphragm top flange with epoxy grout. Immediately bolt the diaphragm in place in accordance with subsection 707.03.D.7.

Clean the galvanized bolts to SSPC-SP 1 condition and apply a tie coat. Apply the tie coat in accordance with the manufacturer's recommended coating thickness. Coat bolts and missed areas with an intermediate coat.

Apply the top coat to the area, including behind the reinstalled diaphragms.

F. Cleaning, Coating and Installing New Hanger Assemblies. Select a coating system from the Qualified Products List meeting the required cure time. Use the same coating system for the joint area as for the remainder of the bridge.

If the dry film exceeds the maximum required thickness, sand to below the maximum thickness and clean before applying subsequent coats. If the maximum time between coats is exceeded, blast clean and recoat newly coated surfaces at no additional cost to the Department.

Modify girder end cleaning and coating procedures as follows for areas within 3 feet of each side of the centerline of the pin holes or the nearest stiffener.

1. Enclose joint areas in accordance with subsection 715.03.B except negative pressure in the containment is not required. The Contractor may remove containment during coating and curing if the temperature is at least 50 °F.

715.03

2. Blast clean joint areas to a white metal finish, in accordance with SSPC-SP 5 White Metal Blast Cleaning(see SSPC-VIS 1 Visual Standards), with a surface profile of 1 mil to 2.8 mils.
3. Enclose and heat joint areas, as acceptable to the Engineer, to maintain steel and air temperatures at 50 °F or higher. If the ambient air temperature at least 50 °F during coating application and curing, enclosing the joint area is not required. If enclosure is required, apply three coats before removing the enclosure. Apply coating when the relative humidity is below 90 percent.
4. Spray on prime coat and cure at 50 °F or higher for at least 12 hours. Provide a dry film thickness of 4 mils to 6 mils.
5. Mask pin holes before applying the intermediate coat. Spray on the epoxy intermediate coat and allow it to cure at 50 °F or higher for at least 12 hours. Provide a dry film thickness of the intermediate coat between 3.5 mils and 6 mils.
6. After the intermediate coat cures for at least 1 hour and is dry to the touch, install the new pins and link plates. Continue curing the epoxy intermediate coat at 50 °F or higher for at least 12 hours.
7. Spray the urethane top coat over assembled joint areas when the temperature is at 40 °F or higher. Apply the final coat as soon as possible after the epoxy intermediate coat cures, but no later than 21 days. Coat the areas behind assembled link plates with urethane top coat to the extent possible. Provide complete coverage and a uniform appearance with the top coat application.
8. If cleaning and coating the remainder of the girder after the joint area, box in or cover the joint area including the new pins and link plates, before blast cleaning and prime coating girders. Remove the box or covering before top coating the girders.
9. If remainder of the girder is cleaned and coated before the joint area, prevent damage to the girder coating during the blast cleaning and coating of the 6-foot joint area. Protect painted girder as approved by the Engineer.

715.04. Measurement and Payment.

Pay Item	Pay Unit
Steel Structure, Cleaning, Type 4 (Structure No.).....	Lump Sum
Steel Structure, Cleaning, Partial, Type 4 (Structure No.).....	Lump Sum
Steel Structure, Coating Type 4 (Structure No.)	Lump Sum
Steel Structure, Coating, Partial, Type 4 (Structure No.).....	Lump Sum
End Diaphragm, Rem and Replace.....	Each
Protective Shield, Utility Pipe.....	Foot

A. **Steel Structure, Cleaning.** The unit prices for **Steel Structure, Cleaning, Type 4** and **Steel Structure, Cleaning, Partial, Type 4** include the cost of protecting the work and environment during blast cleaning, removing loose concrete, providing barges or temporary platforms, enclosures, handling, storage, testing, transporting, and disposal of spent material, bag house dust, and shower water, regardless of hazardous or nonhazardous. The Department will not make additional compensation for suspension of work by the Engineer.

B. **Protective Shield, Utility Pipe.** If pipes or conduits are clustered in groups of at least two, the Engineer will measure the length of the cluster. The unit price for **Protective Shield, Utility Pipe** includes the cost of shielding the utility pipe or conduit during blast cleaning and painting operations, or if required, cleaning and coating existing utility conduits, including brackets and hangers.

C. **End Diaphragm, Rem and Replace.** The unit price for **End Diaphragm, Rem and Replace** includes the cost of shoring the structure while the slab remains unsupported, providing galvanized high strength bolts, and providing and applying epoxy resin to the diaphragm flange.

The unit prices for **Steel Structure, Cleaning, Type 4** and **Steel Structure, Coating, Type 4**, or **Steel Structure, Cleaning, Partial, Type 4** and **Steel Structure, Coating, Partial, Type 4** include the cost of cleaning and prime coating diaphragms.

D. **Stenciling.** The cost of stenciling is included in the unit price for related structure cleaning and coating pay items.

E. **Steel Structure, Coating.** The unit prices for **Steel Structure, Coating, Type 4** and **Steel Structure, Coating, Partial, Type 4** include the cost of coating faying surfaces.

The unit prices for coating pay items include the cost of management, characterization, and disposal of waste solvent.

808.01

Section 808. FENCING

808.01. Description. This work consists of providing and erecting, or moving existing, woven wire fence, temporary fence, protective fence, chain link fence, high-tensile wire fence, or pedestrian fencing of structures.

808.02. Materials. Provide materials in accordance with the following:

Sound Earth.....	<u>205</u>
Concrete, Grade P2.....	<u>601</u>
Fencing Materials	<u>907</u>
Structure Expansion Anchors and Bolts.....	<u>914</u>

A. **Protective Fencing.** Provide new or used material for temporary and protective fencing. Wood posts for protective fencing do not require preservative treatment.

B. **Fence Fabric.** Provide either zinc-coated steel, or aluminum-coated steel fabric for chain link fence. Only use PVC coated fence fabric if required.

C. **Moving and Salvaging Fence.** The Engineer may approve material salvaged from moved, temporary, or protective fencing for use as permanent fence provided it meets the requirements of section 907. Provide additional materials in accordance with section 907.

808.03. Construction. Erect a taut fence to the line required by the contract. Dispose of surplus excavated material and other debris in accordance with subsection 205.03.P. The Engineer will designate and mark trees and other vegetation to be saved. Construct the fence near designated vegetation and in naturally occurring wet areas, by hand, as directed by the Engineer.

A. **Concrete.** Place concrete within 1½ hours of introducing the mixing water. If additional time is necessary to complete concrete placement, use a retarding admixture selected from the Qualified Products List. Follow the manufacturer's recommendation for maximum initial set time. Do not retemper. The Engineer will not allow additional compensation for admixtures.

B. **Woven Wire Fence.** Use wood posts in swamps and areas of unstable soil. If the Engineer approves, substitute wood posts for steel posts in other areas, at no additional cost to the Department.

If necessary to confine livestock, erect the permanent fence before removing the existing fence.

1. **Clearing Fence Line.** Where clearing for fence is required, clear the fence line in accordance with subsection 201.03.C.
2. **Setting Posts.** Dig holes for wood posts in accordance with Standard Plan R-101 Series with a tolerance of ± 3 inches.

Leave at least 4½ feet of the wood post exposed. Set the wood posts plumb on the side designated for fastening the wire. Set with the butt end down. Backfill around the post with sound earth, thoroughly compacted in place.

Use a Department-approved post driver to drive steel line posts. Ensure posts are plumb. Remove and replace bent or damaged posts.

When placing posts, maintain the tops of posts at a uniform height above the ground. After erecting the fence, cut off the tops of wood posts to the required elevation.

Set an intersection post in line with intersecting fences and brace in line with the intersecting fence. Connect both intersecting fences to the intersection post.

3. **Anchoring and Bracing Wood Posts.** Anchor and brace wood posts, except intermediate line posts, in accordance with Standard Plan R-101 Series.

If using cleats to anchor wood posts, use sawed lumber with durability equal to that of the posts. Securely spike timber braces.

Install a double strand, No. 9 galvanized wire, in accordance with Standard Plan R-101 Series. Loop the cable around the end, corner, gate, angle, intersection, or intermediate braced post, and around the adjacent line post. Twist until the top of the adjacent line post is drawn back 2 inches. Secure the cable to maintain tension.

4. **Anchoring and Bracing Steel Posts.** Anchor and brace steel posts, except intermediate line posts not set in concrete, in accordance with Standard Plan R-101 Series.

Brace end and gate posts with one brace in the direction of strain. Brace corner, angle, and intermediate posts in both directions. Brace intersection posts in three directions. Fasten braces near the top of the post. At depressions and alignment angles where stresses are created that may pull the posts from the ground, set the line posts in concrete as shown on the plans.

808.03

5. **Installing Fabric and Barbed Wire.** Wrap each horizontal strand of wire around the end, corner, gate or intermediate braced post and wind around the wire leading up to the post.

Stretch the wire fabric taut and fasten it to each post with the bottom of the fabric 2 inches above the ground. Use line posts as stretching anchorage only if they are anchored in accordance with subsection 808.03.B.4.

Obtain the Engineer's approval for the method of splicing wires in woven wire fabric and barbed wire. Make the distance between the vertical wire stays, next to the splice, equal to the unspliced sections of woven wire fabric. Splice a woven wire and barbed wire fence only if connecting two rolls of wire. Do not make intermediate splices.

Fasten the fence fabric to each steel post with at least six wire clamps.

Attach the fence to each wood post with at least one staple for each horizontal strand. Use staples made of 9 gauge galvanized steel wire, at least 1½ inch long for soft wood, or at least 1 inch for hard wood posts.

Fasten the barbed wire to each post 3 inches to 4 inches above the fabric.

C. **Temporary Fence.** Erect temporary fence in accordance with subsection 808.03.A and subsection 808.03.B, except as modified by the following:

1. **Setting Posts.** Set line posts at least 2 feet and end posts at least 3 feet into the ground and do not trim the tops. The Engineer may allow the omission of intermediate braced posts.
2. **Installing Fabric.** Attach the fabric to wood posts with at least one staple for every third strand, or to steel posts with at least four wire clamps.
3. **Removing Temporary Fence.** Remove and dispose of the temporary fence, or salvage in accordance with subsection 808.02.C.

D. **Protective Fence.** Place a protective fence around excavations for bridges and pump stations, and other areas of the project for public safety in accordance with subsection 104.07 and the plans, or as directed by the Engineer. Erect protective fence in accordance with

subsection 808.03.A and subsection 808.03.B, except as modified by the following.

1. **Anchoring and Bracing Posts.** Anchor and brace enough posts to keep the fabric taut.
 2. **Maintaining Fence.** Maintain the protective fence until the Engineer directs its removal or accepts the project.
 3. **Removing Protective Fence.** Remove and dispose of the protective fence.
- E. **Chain Link Fence.** Erect chain link fence on steel posts set in concrete.
1. **Clearing Fence Line.** Clear and clean the fence line in accordance with subsection 808.03.B.1.
 2. **Setting Posts.** Set posts in concrete and brace. Install angle posts where the alignment of the fence deflects more than 10 degrees.

Set an intersection post in line with intersecting fences. Connect both intersecting fences to the intersection post.

Fit posts with Department-approved post caps.
 3. **Braces.** Fasten braces to the end, corner, angle, intersection, gate, and intermediate braced posts with required steel fasteners.
 4. **Installing Fabric and Top Tension Wire.** Stretch chain link fence fabric taut and fasten to each post with Department-approved fasteners. Space the fasteners no greater than 12 inches apart on the posts. Fasten the fence fabric to the tension wire, at no greater than 15-inch intervals, using fasteners fabricated from 12-gauge galvanized wire. Close fasteners to the full crimp position around the tension wire and fence fabric.
- F. **High-Tensile Wire Fence.** Construct high-tensile wire fence in accordance with subsection 808.03.A and subsection 808.03.B. Erect the wires in accordance with the manufacturer's recommendations.
- G. **Fencing on Structures.** Construct fencing on structures in accordance with subsection 808.03.E. Peen, score, or upset the bolt threads of exposed nuts. Construct handrails, as shown on the plans, as part of the fencing, in accordance with section 707.
- H. **Moving Fence.** Remove the existing fence without damaging the materials. Set posts and anchors in the same manner and to the same depth and spacing as the original fence. Place the reset fence in at least

808.03

as good condition as the existing fence before it was moved. If the fence consists of wire fabric, draw it taut but do not overstress the salvaged materials. Replace damaged or destroyed materials at no additional cost to the Department.

808.04. Measurement and Payment.

Pay Item	Pay Unit
Fence, Temp	Foot
Fence, Protective.....	Foot
Fence, Woven Wire with Wood Post.....	Foot
Fence, Woven Wire with Steel Post.....	Foot
Barbed Wire.....	Foot
Fence Gate, __ foot, for Woven Wire.....	Each
Fence, Chain Link, __ inch.....	Foot
Fence, Chain Link, __ inch, with (number) Strand of Barbed Wire	Foot
Fence Gate, __ foot, for __ inch Chain Link Fence.....	Each
Fence, High Tensile Wire	Foot
Fence, Structure	Square Foot
Fence, Moving.....	Foot
Fence Post	Each
Fence Material.....	Foot

A. **Concrete Acceptance.** Conduct concrete quality control as specified in section 604. The Engineer will conduct quality assurance as specified in section 605. The Department will pay for this work based on the quality assurance results.

B. **Fence.** The Engineer will measure fence in place, and will not include gate openings in the measurement for **Fence, Temp, Fence, Woven Wire, Fence, Moving,** and **Fence, Chain Link**. The Engineer will measure gates separately.

The unit price for fence of the type required includes the cost of providing and installing posts, braces, fabric and hardware.

The Department will not make adjustments in price for handwork required to avoid damage to trees and vegetation designated to be saved.

If required, the Engineer will measure, and the Department will pay for barbed wire separately, unless otherwise included in the unit price for **Fence, Chain Link, __ inch, with (number) Strand of Barbed Wire**.

C. **Temporary and Protective Fence.** The Department will not pay separately for protective fence required in accordance with subsection 104.10.

If the Engineer directs, or the plans show the use of protective fence, the unit price for **Fence, Protective** includes the cost of providing and placing.

The unit prices for **Fence, Temp** and **Fence, Protective** include the cost of providing, erecting, maintaining, removing, and disposing of fence.

The Engineer will not deduct openings from measurements for **Fence, Protective**. The Engineer will not measure gates separately.

D. **Fence, Structure.** The unit price for **Fence, Structure** includes the cost of providing and installing posts, braces, and fabric, and all supporting, connecting, and auxiliary elements, including handrails if shown on the plans, for the erection of fences on existing or new structures.

E. **Fence, Moving.** The Engineer will measure **Fence, Moving** in place, at its new location. The unit price for **Fence, Moving** includes the cost of moving the fence and installing it in its new location. The unit price also includes replacing posts or fabric damaged or destroyed by the Contractor's removal operation.

The Department will pay for new posts or new fence material, if shown on the plans or required by the Engineer, at the contract unit price for these items. If the contract does not include new post or new fence material pay items, the Department will pay for these as extra work.

906.01

Section 906. STRUCTURAL STEEL

906.01. General Requirements. Finished rolled shapes must be free from imperfections that affect strength and durability in accordance with ASTM A 6. Rolled shapes must have a smooth, uniform finish. Straighten rolled shapes in the mill, if necessary, before shipment. Comply with subsection 105.01 and subsection 105.10.

906.02. Testing. Structural steel materials testing will be in accordance with the specified ASTM, AASHTO or Department methods, as modified by this section.

Mechanical testing of structural steel products will be in accordance with ASTM A 6 and AASHTO T 244.

906.03. Mill Inspection. The Engineer will waive mill inspection, unless otherwise specified. If required, the Department will conduct mill inspection in accordance with Division 1, subsection 707.02, and subsection 906.01. Notify the Department before beginning rolling to ensure time for inspection. Provide mill test reports in accordance with subsection 707.02.

906.04. Structural Steel. Steel for use in highway structures must meet the requirements of the contract and this section.

Where impact tests are required, the producer must conduct and report the impact tests for heat qualification according to the sampling and testing procedures of AASHTO T 243. Use the (H) frequency, Heat Testing for Plates, Shapes, and Bars of AASHTO T 243 unless otherwise specified.

The Department considers the average flange thickness to be the governing thickness for beams, tees, and channels. The Department considers the required leg thickness to be the governing thickness for angles. Take test specimens for these sections at one-third the distance from the outer edge of the flange or leg to the web or heel of the section.

The Department may reject any structural steel covered by these requirements, which by subsequent impact testing, conducted at the option of the Department, fails to produce the required impact strength.

A. AASHTO M 270 Grade 36 Structural Steel. Primary member material must meet the longitudinal Charpy V-Notch impact test requirement of 15 foot-pounds at a test temperature of 40 °F. Lower the testing temperature for critical load carrying members by 30 °F, as required.

B. High-Strength Structural Steel. High-strength structural steel must meet the requirements of AASHTO M 270, for Grade 50, Grade 50W Type A, Type B, or Type C, Grade 50S, Grade HPS 50W, and Grade HPS 70W.

Primary member material must meet the longitudinal Charpy V-Notch impact requirements of 15 foot-pounds for 2-inch thick steel and mechanically fastened steel, or 20 foot-pounds for steel thicker than 2 inches, at the following yield points and corresponding testing temperatures:

1. No greater than 65 ksi at 40 °F,
2. From 65 ksi to 75 ksi at 25 °F,
3. From 75 ksi to 85 ksi at 10 °F, and
4. Greater than 85 ksi at -5 °F.

Lower the testing temperature for critical load carrying members by 30 °F, as required.

906.05. Foundation Piles. Ensure the manufacturer of the piling steel provides the Department with a certified mill test report showing the physical properties of the steel.

Foundation piles must meet the following requirements for the type of pile required. If the Engineer determines pile cutoffs are in good condition, the Engineer will accept pile cutoffs that meet size and thickness requirements without mill test reports. If submitting pile cutoffs without mill test reports, provide the Engineer with two copies of an affidavit stating that the material provided meets the contract requirements.

A. Steel H-Piling and Special Sections. Steel H-piling and special sections must meet the requirements of AASHTO M 270 Grade 36, Grade 50, or Grade 50W.

B. Steel Shells for Cast-in-Place Concrete Piles. Steel shells for cast-in-place concrete piles must have the nominal outside diameters and minimum shell metal thicknesses shown on the plans. Cylindrical pipe shells must meet the requirements of ASTM A 252 Grade 2 welded and seamless steel pipe piles.

C. Pile Points. Pile points must conform to the dimensions shown on the plans. Provide certification that the steel used for the fabrication of the points meets one of the following:

1. AASHTO M 270 Grade 36, Grade 50, or Grade 50W;
2. SAE Grade 1016 through Grade 1027; or
3. SAE Grade 1030.

906.06

906.06. Sheet Piles. For permanent sheet piling, ensure the piling steel manufacturer provides the Department with a certified mill test report that shows the physical properties of the steel.

Sheet piles must meet the following requirements for the type of pile required. If the Engineer determines pile cutoffs are in good condition, the Engineer will accept pile cutoffs that meet the size and thickness requirements without mill test reports. If submitting pile cutoffs without mill test reports, provide the Engineer with two copies of an affidavit stating that the material provided meets the contract requirements.

A. Temporary Steel Sheet Piling. Temporary steel sheet piling must meet the requirements of AASHTO M 202 or AASHTO M 270 Grade 36, Grade 50, or Grade 50W.

B. Permanent Steel Sheet Piling. Permanent steel sheet piling must meet the requirements of AASHTO M 270 Grade 50.

906.07. High-Strength Steel Bolts, Nuts, and Washers for Structural Joints. High-strength bolt fasteners for structural joints must meet the requirements of AASHTO M 164 Type 1 bolts. High-strength nuts for structural joints must meet the requirements of AASHTO M 291 Grade DH or AASHTO M 292 Grade 2H. High-strength washers for structural joints must meet the requirements of AASHTO M 293 Type 1 for circular, beveled, clipped circular, and clipped beveled washers.

Bolts, nuts, and washers must be hot dip galvanized in accordance with AASHTO M 232. Galvanized nuts must be tapped oversize in accordance with AASHTO M 291 and meet Supplementary Requirements S1, Lubricant and Rotational Capacity Test for Coated Nuts and S2, Lubricant Dye.

906.08. Pins and Link Plates for Steel Bridge Construction. Link plates for steel bridge construction must meet the requirements of AASHTO M 270 Grade 50 or Grade 50W, and pins must meet the requirements of ASTM A 276 UNS designation S21800 or S20161 annealed stainless steel with 50 ksi yield point. Washers and pins must be made from the same material.

The Longitudinal Charpy V-Notch impact values for pin and link plate materials in redundant structures must meet the requirements for high strength structural steel in subsection 906.04. Use the steel yield point stress value shown in the certified mill test report to determine the testing temperature. The steel may require heat treatment to meet the Charpy V-Notch impact requirements.

Perform notch toughness tests on specimens in accordance with Frequency (P) Piece Testing of AASHTO T 243.

The longitudinal Charpy V-Notch impact values for pin and link plate materials in non-redundant structures must average 30 foot-pounds when tested at the Lowest Anticipated Service Temperature (LAST) specified for the MDOT Region location of the structure in accordance with Table 906-1.

Region	LAST
Superior	-25 °F
North	-20 °F
Grand and Bay	-15 °F
Southwest, University, and Metro	-10 °F

906.09. Shear Developers. Select shear connector studs from the Qualified Products List. Shear connector studs must be designed for end-welding to steel beams and girders with automatically timed stud welding equipment. Provide shear developers as shown on the plans.

Provide an arc shield (ferrule) with each stud. The arc shield must be made of a heat-resistant ceramic or material that will not adversely affect the welds, cause excessive slag, or crumble or break from thermal or structural shock during welding.

Furnish flux for welding with each stud, either attached to the end of the stud or combined with the arc shield for automatic application in the welding operation.

Shear connector studs must meet the requirements of AASHTO M 169, for cold-finished carbon steel, cold-drawn bar, Grade 1015 or Grade 1020, either semi-killed or fully-killed. If using flux-retaining caps, provide cold-rolled steel caps of a low carbon grade for welding, that meet the requirements of ASTM A 109.

Tensile properties, as determined by tests of bar stock after drawing or of finished studs, must conform to the minimum requirements shown in Table 906-2.

Property	Specification (minimum)
Tensile strength	60 ksi
Yield strength	50 ksi
Elongation	20% in 2 inches
Reduction of area	50%

906.09

Determine tensile properties in accordance with AASHTO T 244 for mechanical testing of steel products. Use the 0.2 percent offset method to determine the yield strength.

Finished studs must be uniform in quality and condition, free from injurious laps, fins, seams, cracks, twists, bends, or other defects. Use cold drawing, cold rolling, or machining to finish.

915.01

Section 915. BRIDGE COATING SYSTEMS

915.01. General Requirements. Select a complete coating system from the Qualified Products List for each structure. Use the same coating system for all coating repairs to the structure including warranty work. The system must consist of a tinted organic zinc-rich primer, a white intermediate coat, and a urethane top coat matching the Federal Standards No. 595B color number, as shown on the plans. For faying surfaces of slip critical bolted connections, use a zinc-rich primer meeting the requirements for Class B slip coefficient, selected from the Qualified Products List.

Before coating, provide the Engineer with the product data sheets showing mixing and thinning directions, and the manufacturer-recommended spray nozzles and pressures for each product. Provide the Engineer with documentation stating the date of manufacture for the coating product components.

Use spray equipment to apply the coating. The coating products and the thinners must arrive at the project in new, unopened containers. Coating containers must be labeled with the manufacturer's name, product name, batch number, and date of manufacture.

915.02. Mixing the Coating. Using a high shear mixer, mix the coating in accordance with the manufacturer's recommendations, to a homogenous consistency. Do not use paddle mixers or paint shakers. Mix until the metallic powder or pigment is in suspension. Disperse coating solids that may settle to the bottom of the container. Strain the primer through a screen with openings no greater than a No. 30 sieve meeting the requirements of ASTM E 11. After straining, continuously agitate the primer until application is complete.

915.03. Thinning the Coating. Do not thin the coating, unless otherwise recommended by the coating manufacturer. For thinning the coating, provide thinners recommended by the coating manufacturer. Do not exceed the manufacturer's recommended thinning limits.

915.04. Conditions for Coating. Apply coatings under the conditions specified by this subsection.

A. **Temperature.** Do not apply coatings if air or steel temperature is greater than 100 °F, or if the steel temperature is less than 5 °F higher than the dew point. Apply the primer and intermediate coats if air, coating material, and steel temperatures exceed 50 °F. Apply the top coat if air, coating material, and steel temperatures exceed 40 °F. Unless the manufacturer recommends a longer recoat time, maintain the

specified minimum air and steel temperatures between coats for 24 hours in the field, or for 16 hours in the fabrication shop.

B. **Humidity.** Do not apply coating if the relative humidity exceeds 90 percent, or if temperature and humidity conditions cause moisture to condense on the surfaces requiring coating. Use a psychrometer to measure the humidity.

C. **Heating.** If heating is required, heaters must maintain air and steel temperatures from 50 °F to 100 °F without discharging oils or other pollutants into the enclosure.

D. **Storage and Shelf Life of Coating.** Store the coating materials in accordance with the manufacturer's directions. Use coating within one year of the date of manufacture, unless product data sheets indicate a shorter shelf life.

APPENDIX

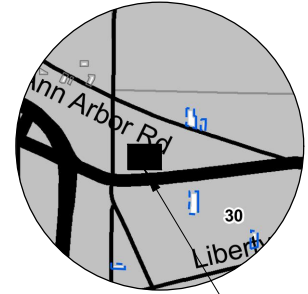
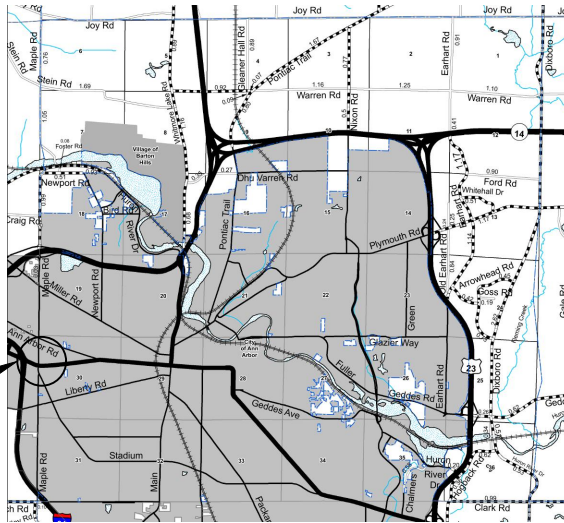

PROJECT LOCATION



PROJECT LOCATION
 VETERAN'S MEMORIAL PARK
 POOL AND ICE ARENA
 2150 JACKSON RD.
 ANN ARBOR, MI 48103

LOCATION MAP

SCALE: N.T.S

PROPERTY ADDRESS

CITY OF ANN ARBOR
 VETERAN'S MEMORIAL PARK POOL AND ICE ARENA
 2150 JACKSON ROAD
 ANN ARBOR, MI 48103

ENGINEER INFORMATION

DOUG SHULTZ, P.L.A.
 ROWE PROFESSIONAL SERVICES COMPANY
 540 S. SAGINAW STREET, SUITE 200
 FLINT, MI 48502
 (810) 341-7500

PROJECT DESCRIPTION

REHABILITATION, CLEANING, AND PAINTING OF POOL SLIDE
 SUPPORT STRUCTURE.

USE GROUP: ASSEMBLY GROUP A-5
 CONSTRUCTION TYPE: EXISTING (SB)
 DESIGN OCCUPANCY: EXISTING AND UNAFFECTED
 CODE REFERENCES: 2015 REHABILITATION CODE FOR EXISTING BUILDINGS
 (WORK AREA COMPLIANCE METHOD)
 ICC/ANSI A 117.1 - 2009
 MBF, P.A.1 1996



The Rowe Building
 540 S. Saginaw St., Suite 200
 Flint, MI 48502

O: (810) 341-7500
 F: (810) 341-7573
 www.rowepsc.com

PREPARED FOR:
CITY OF ANN ARBOR
 VETERAN'S MEMORIAL PARK POOL WATERSLIDE STAIR IMPROVEMENTS

PLAN NO. _____ 20C0108
 DATE: _____ 5/9/2020
 PROJECT MGR: _____ DRS
 REVIEWER: _____ JGB
 SCALE: _____ NTS SHEET NO: _____ 1

LOG OF PROJECT

Page 2 of 6

PROJECT DESCRIPTION:

This project is for the repair, cleaning, and painting of the Veteran's Memorial Park Pool slide support structure. The slide is located in the northwest corner of the pool and is comprised of a steel support structure, a fiberglass slide, and a wooden railing system. The scope of this project includes the removal of the wooden railing with care taken to not damage the railing to allow for reuse, the erection of proper containment, the complete paint removal and cleaning of the entire steel support structure, the removal and replacing in kind or repairing of all steel members that are determined structurally inadequate by the engineer or have more than 10% loss of section due to rust including the known deteriorated sections listed below, the complete painting of the entire support structure, and the reattaching of the existing wooden railing. The aluminum stair treads and landings are to be removed and safely stored for reuse and shall not be painted. Care is to be taken to ensure 100% of rust is removed in the cleaning process and shall be approved by the engineer prior to painting operations.

DESCRIPTION OF WORK:

Railing Removal:

The existing wooden railing is to be removed and stored on site in an area designated by the owner in accordance to MDOT 2012 Standard Specification for Construction Section 808 with care taken as to not damage the railing. The contractor will be responsible for any damage to the railing during the entirety of the project. The railing is to be replaced once the cleaning and painting of the supports is completed.

Replacing of Damaged Steel:

If it is determined by the engineer that the damage to a steel member is greater than 10% of the total section area after cleaning has been completed, that member is to be replaced in kind, or repaired to the satisfaction of the engineer. All steel repairs and steel members will conform to MDOT 2012 Standard Specifications for Construction Section 713 and shall be Grade 36 steel. Field weld in accordance with subsection 707.03.D.8, with the exception that the field welding shall be in accordance with AWS D1.1, Structural Steel Welding Code. All welds shall be a minimum of 1/4" fillet welds.

List of known steel members and locations that shall be replaced in kind (lengths are approximate and need to be verified in field):

Shape	Length	Locations
3"x1.5"x.125" Tube	(3) at 4'-9"	Steel tubing at each of the 3 landings
2"x2"x.125" Tube	(2) at 11'-4"	Water stack diagonal supports in main tower

Cleaning and Painting:

All cleaning and painting to follow MDOT 2012 Standard Specification for Construction Section 715. The color of the paint is to be determined by the client prior to the beginning of the project.

Below is a table of all steel member sizes and approximate total lengths. This table is for information only and is intended to quantify the amount of steel required to be cleaned and

LOG OF PROJECT

Page 3 of 6

painted. All sizing and lengths are approximate and should be verified in field. Not included are all gusset plates and mounting brackets.

Member	Total Length (ft)	Typical Location
6"x6" Square Tube	57.5	Main tower vertical supports
3"x6" Square Tube	57.5	Slide support arms and vertical column
12" Circular Tube	32.33	Slide vertical columns
6" Circular Tube	1	Slide vertical column
2"x2" Square Tube	22.67	Water stack diagonal support in main tower
C 10"x1.5"x.25" Channel	128.67	Railing and stair channel
C 6x13 Channel	88.42	Landing supports
L 2"x2"x.25" Angle	122.33	Landing supports and tower bracing
0.5" Threaded Rods	160	Tower bracing
3"x1.5" Square Tube	14.25	Landings

Site Use:

If there is a need for staging and storage outside of the pool perimeter fencing, there is a parking lot to the west of the slide that may be used for storage and staging. The contractor is responsible for the security of this area for the duration of the project and the cost is to be included in the cost of the project in accordance to MDOT 2012 Standard Specification for Construction Section 808. Public access of this lot must be maintained for the duration of this project.

If the need to remove any of the perimeter fencing is required to complete this project, the contractor will be responsible for removal of, safe on-site storage, and reinstallation of the fencing in accordance to MDOT 2012 Standard Specification for Construction Section 808. The cost for this shall be included in the cost of the project. The contractor will be responsible for any damage that occurs to the fencing for the duration of the project.

GENERAL PLAN NOTES:

Underground Utilities

For protection of underground utilities and in accordance with Public Act 53, 1974, the Contractor shall dial MISS DIG at 1-800-482-7171 (or 811), a minimum of three working days prior to starting any excavation. All "Miss Dig" participating members will thus be routinely notified. This does not relieve the contractor of the responsibility of contacting utility owners who may not be a part of the "Miss Dig" system.

Specifications for Construction

Plans shall be completed in accordance with the Michigan Department of Transportation 2012 Standard Specifications for Construction, Special Provisions and Supplemental specifications combined in this proposal.

LOG OF PROJECT

Page 4 of 6

Bidding

Submittal of bids shall be considered prima facie evidence that bidders (and prospective sub-Contractors) have performed site investigations and otherwise investigated the existing surface and subsurface conditions to the bidder's satisfaction and has included all costs related to surface and subsurface conditions in the contract unit price of the contract pay items. Additional cost and time due to surface or subsurface conditions shall not be considered as a basis of claims by the Contractor for additional compensation or contract time.

Safety

MIOSHA safety requirements shall be adhered to at all times. All work, work practice, and materials shall comply with all applicable state and federal safety, occupational, health and environmental regulations and also NFPA and ANSI codes as applicable. All work inside confined spaces such as manholes or other underground structures shall be coordinated with the utility owner and all worker safety requirements shall be strictly enforced.

Soil Erosion/Soil Control

Soil erosion and sediment control devices shall be utilized on this project to effectively reduce accelerated soil erosion and sedimentation, including but not limited to, permanent and temporary seeding, inlet protection-fabric drop, and silt fence in the event any earthwork is required during the project to restore the staging areas.

Protecting Existing Features

The slide, buildings, fencing, concrete deck and sidewalk and all other existing features will be protected during construction. Any damages will be restored or replaced in-kind at contractors expense. A pre-construction video will be completed prior to any activities at the site.

Local Access

Contractor shall maintain access to the park and pool building at all times. Contractor shall notify the City of Ann Arbor Parks and Recreation Office as well as the Veterans Memorial Park facility manager in writing 72 hours in advance to any proposed work.

Project Cleanup

The Contractor shall provide project cleanup in accordance with the cleaning specification. All costs shall be included in the project and shall not be paid for separately.

LOG OF PROJECT
Page 5 of 6

SITE VIEW:

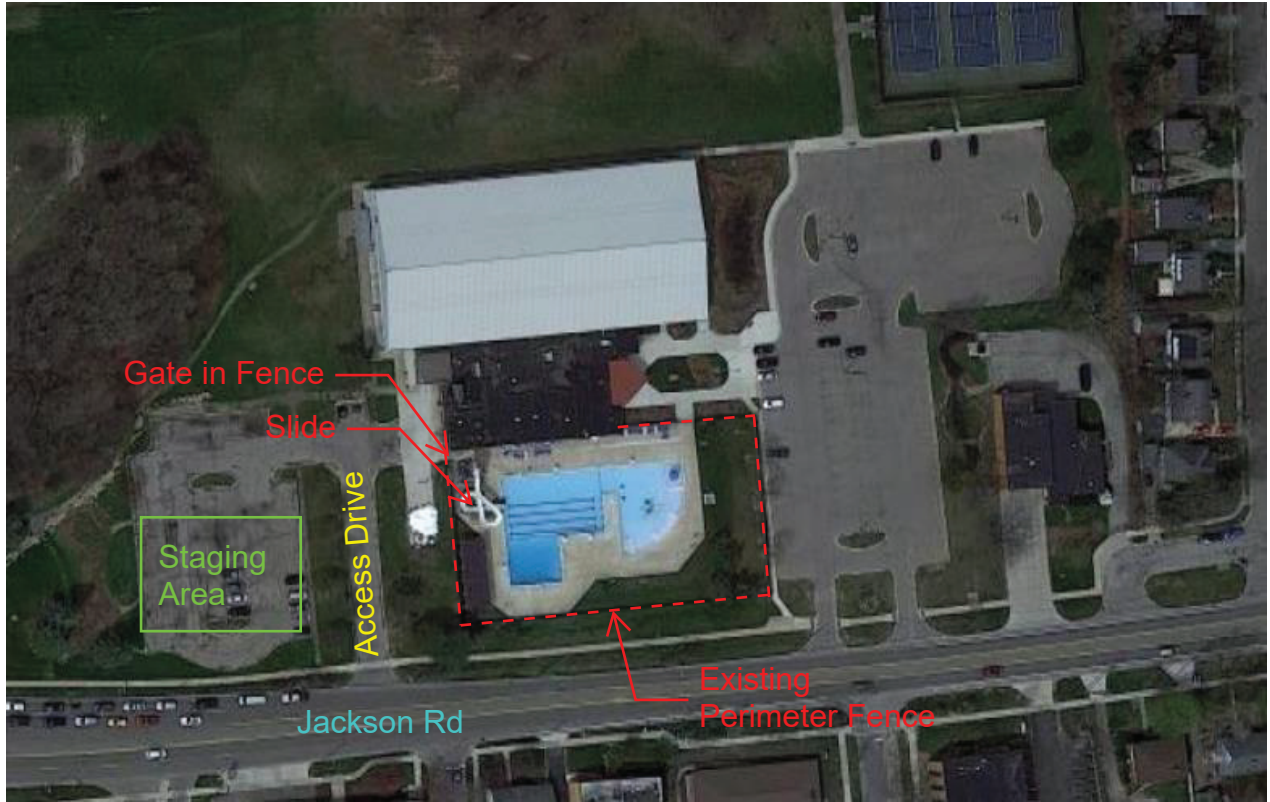

LOG OF PROJECT

Page 6 of 6

PROJECT PHOTOS:



+17.0'

+15.5'

+9.75'

+5.0'

+0.0'

ELEVATION VIEW OF SLIDE



Tubing to be replaced

3" X 1½" STEEL TUBE AT LANDING
(TO BE REPLACED)



Tubing to be replaced

2" X 2" STEEL TUBE AT WATER STACK
(TO BE REPLACED)



RAILING ALONG STAIRS (TYPICAL)

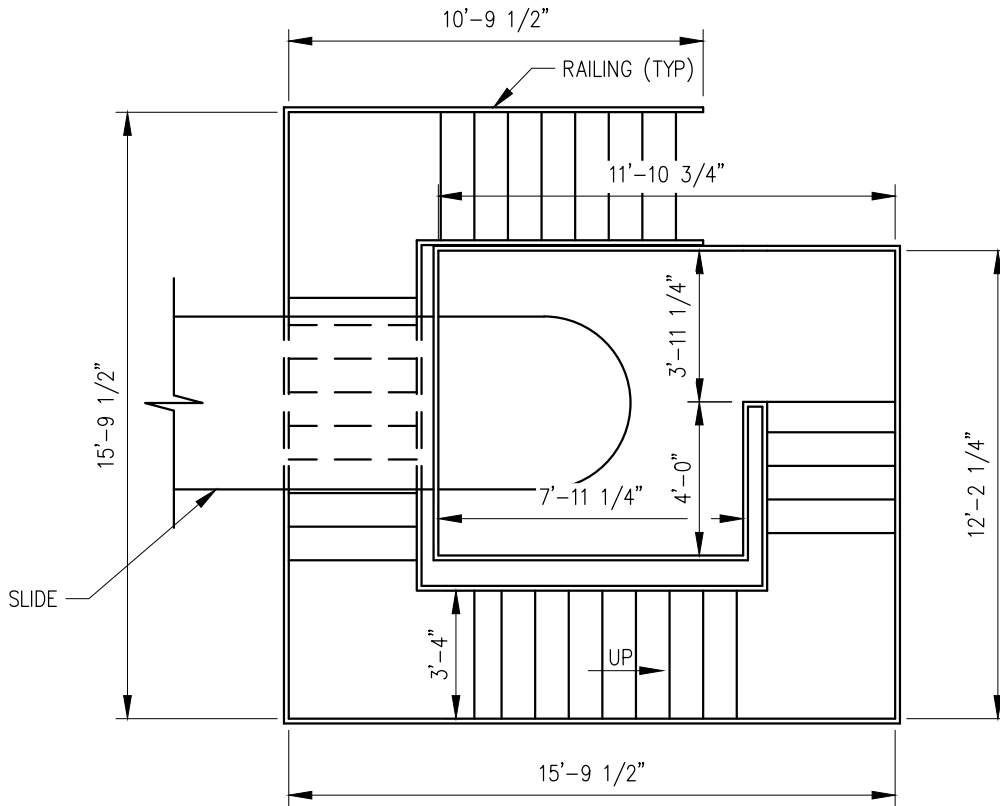

PLAN VIEW OF MAIN TOWER

(NOT TO SCALE)

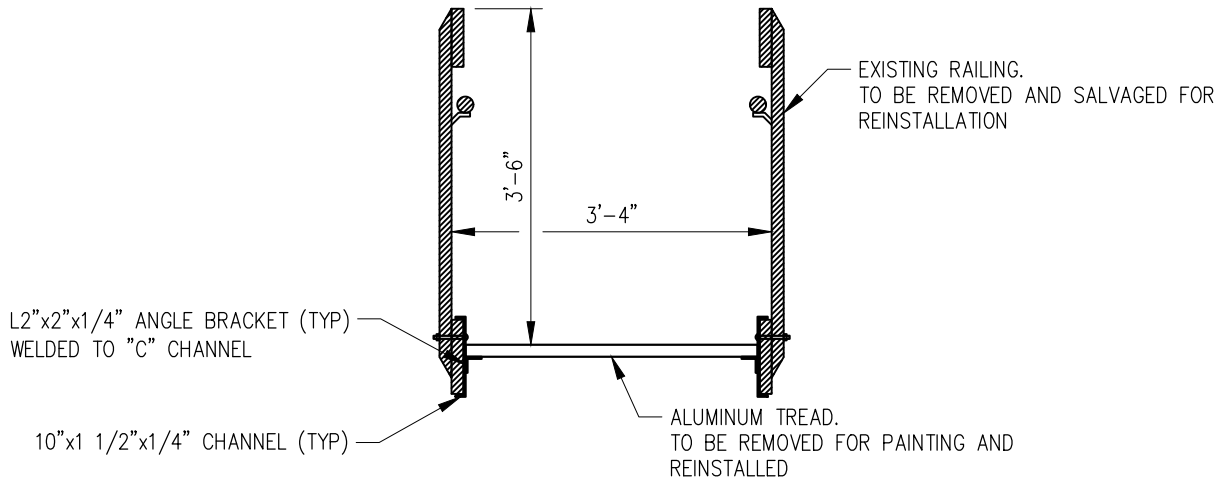

TYPICAL STAIR SECTION

(NOT TO SCALE)



The Rowe Building
540 S. Saginaw St., Suite 200
Flint, MI 48502

O: (810) 341-7500
F: (810) 341-7573
www.rowepsc.com

PREPARED FOR:
CITY OF ANN ARBOR
VERTERAN'S MEMORIAL PARK POOL WATERSLIDE STAIR IMPROVEMENTS
DETAILS

PLAN NO. 20C0108
DATE: 5/9/2020
PROJECT MGR: DRS
REVIEWER: JGB
SCALE: NTS SHEET NO: 7

CITY OF ANN ARBOR
LIVING WAGE ORDINANCE DECLARATION OF COMPLIANCE

The Ann Arbor Living Wage Ordinance (Section 1:811-1:821 of Chapter 23 of Title I of the Code) requires that an employer who is (a) a contractor providing services to or for the City for a value greater than \$10,000 for any twelve-month contract term, or (b) a recipient of federal, state, or local grant funding administered by the City for a value greater than \$10,000, or (c) a recipient of financial assistance awarded by the City for a value greater than \$10,000, shall pay its employees a prescribed minimum level of compensation (i.e., Living Wage) for the time those employees perform work on the contract or in connection with the grant or financial assistance. The Living Wage must be paid to these employees for the length of the contract/program.

Companies employing fewer than 5 persons and non-profits employing fewer than 10 persons are exempt from compliance with the Living Wage Ordinance. If this exemption applies to your company/non-profit agency please check here No. of employees__

The Contractor or Grantee agrees:

- (a) To pay each of its employees whose wage level is not required to comply with federal, state or local prevailing wage law, for work covered or funded by a contract with or grant from the City, no less than the Living Wage. The current Living Wage is defined as \$13.91/hour for those employers that provide employee health care (as defined in the Ordinance at Section 1:815 Sec. 1 (a)), or no less than \$15.51/hour for those employers that do not provide health care. The Contractor or Grantor understands that the Living Wage is adjusted and established annually on April 30 in accordance with the Ordinance and covered employers shall be required to pay the adjusted amount thereafter to be in compliance with Section 1:815(3).

Check the applicable box below which applies to your workforce

Employees who are assigned to any covered City contract/grant will be paid at or above the applicable living wage without health benefits

Employees who are assigned to any covered City contract/grant will be paid at or above the applicable living wage with health benefits

- (b) To post a notice approved by the City regarding the applicability of the Living Wage Ordinance in every work place or other location in which employees or other persons contracting for employment are working.
- (c) To provide to the City payroll records or other documentation within ten (10) business days from the receipt of a request by the City.
- (d) To permit access to work sites to City representatives for the purposes of monitoring compliance, and investigating complaints or non-compliance.
- (e) To take no action that would reduce the compensation, wages, fringe benefits, or leave available to any employee covered by the Living Wage Ordinance or any person contracted for employment and covered by the Living Wage Ordinance in order to pay the living wage required by the Living Wage Ordinance.

The undersigned states that he/she has the requisite authority to act on behalf of his/her employer in these matters and has offered to provide the services or agrees to accept financial assistance in accordance with the terms of the Living Wage Ordinance. The undersigned certifies that he/she has read and is familiar with the terms of the Living Wage Ordinance, obligates the Employer/Grantee to those terms and acknowledges that if his/her employer is found to be in violation of Ordinance it may be subject to civil penalties and termination of the awarded contract or grant of financial assistance.

 Company Name

 Street Address

 Signature of Authorized Representative

 Date

 City, State, Zip

 Print Name and Title

 Phone/Email address

CITY OF ANN ARBOR LIVING WAGE ORDINANCE

RATE EFFECTIVE APRIL 30, 2020 - ENDING APRIL 29, 2021

\$13.91 per hour

If the employer provides health care benefits*

\$15.51 per hour

If the employer does **NOT** provide health care benefits*

Employers providing services to or for the City of Ann Arbor or recipients of grants or financial assistance from the City of Ann Arbor for a value of more than \$10,000 in a twelve-month period of time must pay those employees performing work on a City of Ann Arbor contract or grant, the above living wage.

ENFORCEMENT

The City of Ann Arbor may recover back wages either administratively or through court action for the employees that have been underpaid in violation of the law. Persons denied payment of the living wage have the right to bring a civil action for damages in addition to any action taken by the City.

Violation of this Ordinance is punishable by fines of not more than \$500/violation plus costs, with each day being considered a separate violation. Additionally, the City of Ann Arbor has the right to modify, terminate, cancel or suspend a contract in the event of a violation of the Ordinance.

* Health Care benefits include those paid for by the employer or making an employer contribution toward the purchase of health care. The employee contribution must not exceed \$.50 an hour for an average work week; and the employer cost or contribution must equal no less than \$1/hr for the average work week.

The Law Requires Employers to Display This Poster Where Employees Can Readily See It.

**For Additional Information or to File a Complaint contact
Colin Spencer at 734/794-6500 or cspencer@a2gov.org**



Vendor Conflict of Interest Disclosure Form
--

All vendors interested in conducting business with the City of Ann Arbor must complete and return the Vendor Conflict of Interest Disclosure Form in order to be eligible to be awarded a contract. Please note that all vendors are subject to comply with the City of Ann Arbor’s conflict of interest policies as stated within the certification section below.

If a vendor has a relationship with a City of Ann Arbor official or employee, an immediate family member of a City of Ann Arbor official or employee, the vendor shall disclose the information required below.

1. No City official or employee or City employee’s immediate family member has an ownership interest in vendor’s company or is deriving personal financial gain from this contract.
2. No retired or separated City official or employee who has been retired or separated from the City for less than one (1) year has an ownership interest in vendor’s Company.
3. No City employee is contemporaneously employed or prospectively to be employed with the vendor.
4. Vendor hereby declares it has not and will not provide gifts or hospitality of any dollar value or any other gratuities to any City employee or elected official to obtain or maintain a contract.
5. Please note any exceptions below:

Conflict of Interest Disclosure*	
Name of City of Ann Arbor employees, elected officials or immediate family members with whom there may be a potential conflict of interest.	<input type="checkbox"/> Relationship to employee <hr style="border: 0; border-top: 1px solid black;"/> <input type="checkbox"/> Interest in vendor’s company <input type="checkbox"/> Other (please describe in box below)

*Disclosing a potential conflict of interest does not disqualify vendors. In the event vendors do not disclose potential conflicts of interest and they are detected by the City, vendor will be exempt from doing business with the City.

I certify that this Conflict of Interest Disclosure has been examined by me and that its contents are true and correct to my knowledge and belief and I have the authority to so certify on behalf of the Vendor by my signature below:		
Vendor Name	Vendor Phone Number	
Signature of Vendor Authorized Representative	Date	Printed Name of Vendor Authorized Representative

CITY OF ANN ARBOR NON-DISCRIMINATION ORDINANCE

Relevant provisions of Chapter 112, Nondiscrimination, of the Ann Arbor City Code are included below.
You can review the entire ordinance at www.a2gov.org/humanrights.

Intent: It is the intent of the city that no individual be denied equal protection of the laws; nor shall any individual be denied the enjoyment of his or her civil or political rights or be discriminated against because of actual or perceived age, arrest record, color, disability, educational association, familial status, family responsibilities, gender expression, gender identity, genetic information, height, HIV status, marital status, national origin, political beliefs, race, religion, sex, sexual orientation, source of income, veteran status, victim of domestic violence or stalking, or weight.

Discriminatory Employment Practices: No person shall discriminate in the hire, employment, compensation, work classifications, conditions or terms, promotion or demotion, or termination of employment of any individual. No person shall discriminate in limiting membership, conditions of membership or termination of membership in any labor union or apprenticeship program.

Discriminatory Effects: No person shall adopt, enforce or employ any policy or requirement which has the effect of creating unequal opportunities according to actual or perceived age, arrest record, color, disability, educational association, familial status, family responsibilities, gender expression, gender identity, genetic information, height, HIV status, marital status, national origin, political beliefs, race, religion, sex, sexual orientation, source of income, veteran status, victim of domestic violence or stalking, or weight for an individual to obtain housing, employment or public accommodation, except for a bona fide business necessity. Such a necessity does not arise due to a mere inconvenience or because of suspected objection to such a person by neighbors, customers or other persons.

Nondiscrimination by City Contractors: All contractors proposing to do business with the City of Ann Arbor shall satisfy the contract compliance administrative policy adopted by the City Administrator in accordance with the guidelines of this section. All city contractors shall ensure that applicants are employed and that employees are treated during employment in a manner which provides equal employment opportunity and tends to eliminate inequality based upon any classification protected by this chapter. All contractors shall agree not to discriminate against an employee or applicant for employment with respect to hire, tenure, terms, conditions, or privileges of employment, or a matter directly or indirectly related to employment, because of any applicable protected classification. All contractors shall be required to post a copy of Ann Arbor's Non-Discrimination Ordinance at all work locations where its employees provide services under a contract with the city.

Complaint Procedure: If any individual believes there has been a violation of this chapter, he/she may file a complaint with the City's Human Rights Commission. The complaint must be filed within 180 calendar days from the date of the individual's knowledge of the allegedly discriminatory action or 180 calendar days from the date when the individual should have known of the allegedly discriminatory action. A complaint that is not filed within this timeframe cannot be considered by the Human Rights Commission. To file a complaint, first complete the complaint form, which is available at www.a2gov.org/humanrights. Then submit it to the Human Rights Commission by e-mail (hrc@a2gov.org), by mail (Ann Arbor Human Rights Commission, PO Box 8647, Ann Arbor, MI 48107), or in person (City Clerk's Office). For further information, please call the commission at 734-794-6141 or e-mail the commission at hrc@a2gov.org.

Private Actions For Damages or Injunctive Relief: To the extent allowed by law, an individual who is the victim of discriminatory action in violation of this chapter may bring a civil action for appropriate injunctive relief or damages or both against the person(s) who acted in violation of this chapter.

THIS IS AN OFFICIAL GOVERNMENT NOTICE AND
MUST BE DISPLAYED WHERE EMPLOYEES CAN READILY SEE IT.

MICHIGAN DEPARTMENT OF TRANSPORTATION CERTIFIED PAYROLL

COMPLETION OF CERTIFIED PAYROLL FORM FULFILLS THE MINIMUM MDOT PREVAILING WAGE REQUIREMENTS

(1) NAME OF CONTRACTOR / SUBCONTRACTOR (CIRCLE ONE) (2) ADDRESS

(3) PAYROLL NO. (4) FOR WEEK ENDING (5) PROJECT AND LOCATION (6) CONTRACT ID

(a)	(b)	(c)	(d) DAY AND DATE							(e)	(f)	(g)	(h)		(i)	(j) DEDUCTIONS					(k)			
			Hour Type	MON	TUE	WED	THU	FRI	SAT				SUN	TOTAL HOURS ON PROJECT		PROJECT RATE OF PAY	PROJECT RATE OF FRINGE PAY	GROSS PROJECT EARNED	GROSS WEEKLY EARNED	TOTAL WEEKLY HOURS WORKED ALL JOBS		FICA	FEDERAL	STATE
EMPLOYEE INFORMATION NAME:	WORK CLASSIFICATION									0					\$0.00								\$0.00	\$0.00
ETH#GEN: ID #: GROUP/CLASS #:		S								0					\$0.00								\$0.00	\$0.00
NAME:										0					\$0.00								\$0.00	\$0.00
ETH#GEN: ID #: GROUP/CLASS #:		S								0					\$0.00								\$0.00	\$0.00
NAME:										0					\$0.00								\$0.00	\$0.00
ETH#GEN: ID #: GROUP/CLASS #:		S								0					\$0.00								\$0.00	\$0.00
NAME:										0					\$0.00								\$0.00	\$0.00
ETH#GEN: ID #: GROUP/CLASS #:		S								0					\$0.00								\$0.00	\$0.00
NAME:										0					\$0.00								\$0.00	\$0.00
ETH#GEN: ID #: GROUP/CLASS #:		S								0					\$0.00								\$0.00	\$0.00
NAME:										0					\$0.00								\$0.00	\$0.00
ETH#GEN: ID #: GROUP/CLASS #:		S								0					\$0.00								\$0.00	\$0.00
NAME:										0					\$0.00								\$0.00	\$0.00

Date _____

I, _____ (Name of Signatory Party) _____ (Title)

do hereby state:

(1) That I pay or supervise the payment of the persons employed by

_____ on the
 _____ (Contractor or Subcontractor)
 _____; that during the payroll period commencing on the
 _____ (Building or Work)
 _____ day of _____, _____, and ending the _____ day of _____, _____,
 all persons employed on said project have been paid the full weekly wages earned, that no rebates have
 been or will be made either directly or indirectly to or on behalf of said

_____ from the full
 _____ (Contractor or Subcontractor)
 weekly wages earned by any person and that no deductions have been made either directly or indirectly
 from the full wages earned by any person, other than permissible deductions as defined in Regulations, Part
 3 (29 C.F.R. Subtitle A), issued by the Secretary of Labor under the Copeland Act, as amended (48 Stat. 948,
 63 Stat. 108, 72 Stat. 967; 76 Stat. 357; 40 U.S.C. § 3145), and described below:

(2) That any payrolls otherwise under this contract required to be submitted for the above period are
 correct and complete; that the wage rates for laborers or mechanics contained therein are not less than the
 applicable wage rates contained in any wage determination incorporated into the contract; that the
 classifications set forth therein for each laborer or mechanic conform with the work he performed.

(3) That any apprentices employed in the above period are duly registered in a bona fide
 apprenticeship program registered with a State apprenticeship agency recognized by the Bureau of
 Apprenticeship and Training, United States Department of Labor, or if no such recognized agency exists in a
 State, are registered with the Bureau of Apprenticeship and Training, United States Department of Labor.

(4) That:

(a) WHERE FRINGE BENEFITS ARE PAID TO APPROVED PLANS, FUNDS, OR PROGRAMS

- in addition to the basic hourly wage rates paid to each laborer or mechanic listed in
 the above referenced payroll, payments of fringe benefits as listed in the contract
 have been or will be made to appropriate programs for the benefit of such
 employees, except as noted in section 4(c) below.

(b) WHERE FRINGE BENEFITS ARE PAID IN CASH

- Each laborer or mechanic listed in the above referenced payroll has been paid,
 as indicated on the payroll, an amount not less than the sum of the applicable
 basic hourly wage rate plus the amount of the required fringe benefits as listed
 in the contract, except as noted in section 4(c) below.

(c) EXCEPTIONS

EXCEPTION (CRAFT)	EXPLANATION

REMARKS:

NAME AND TITLE	SIGNATURE

THE WILLFUL FALSIFICATION OF ANY OF THE ABOVE STATEMENTS MAY SUBJECT THE CONTRACTOR OR
 SUBCONTRACTOR TO CIVIL OR CRIMINAL PROSECUTION. SEE SECTION 1001 OF TITLE 18 AND SECTION 231 OF TITLE
 31 OF THE UNITED STATES CODE.