

ANN ARBOR HISTORIC DISTRICT COMMISSION

Staff Report

ADDRESS: 520 Sixth Street, Application Number HDC21-206

DISTRICT: Old West Side Historic District

REPORT DATE: July 8, 2021

REPORT PREPARED BY: Jill Thacher, Historic Preservation Coordinator

REVIEW COMMITTEE DATE: Tuesday, July 6, 2021

| | OWNER | APPLICANT |
|-----------------|---|------------------|
| Name: | Luke Rodehorst Lilly Connett | Same |
| Address: | 520 Sixth Street Ann Arbor, MI 48103 | |
| Phone: | (440) 821-8294 | |

BACKGROUND: This two-story gable-fronter features wide board eave trim, an ornate full-width front porch and a cut stone foundation. It is listed in the 1894 Polk City Directory as number 8 Sixth Street, the Schoettle residence.

LOCATION: The house is located on the west side of Sixth Street, south of West Jefferson and north of West Madison Streets.

APPLICATION: The applicant seeks HDC approval to construct a 20 square foot rear second-floor addition on a modern addition; remove a 20 square foot bump out and add five windows on the north elevation of the modern north addition; remove a modern chimney; on the rear, alter many windows on the modern addition, replace a non-original pair of casement windows on the historic house with a single one-over-one window, add a new single-lite person door and add a one-over-one window in a new opening on the second floor of the modern south addition; and on the south elevation, replace a casement window on the second-floor of the modern south addition with a slightly larger double-hung egress window.

APPLICABLE REGULATIONS:

From the Secretary of the Interior's Standards for Rehabilitation:

- (1) A property will be used as it was historically or be



given a new use that requires minimal change to its distinctive materials, features, spaces, and spatial relationships.

- (2) The historic character of a property will be retained and preserved. The removal of distinctive materials or alteration of features, spaces, and spatial relationships that characterize a property will be avoided.
- (5) Distinctive features, finishes, and construction techniques or examples of craftsmanship that characterize a property shall be preserved.
- (9) New additions, exterior alterations, or related new construction shall not destroy historic materials that characterize the property. The new work shall be differentiated from the old and shall be compatible with the massing, size, scale, and architectural features to protect the historic integrity of the property and its environment.
- (10) New additions and adjacent or related new construction shall be undertaken in such a manner that if removed in the future, the essential form and integrity of the historic property and its environment would be unimpaired.

From the Secretary of the Interior's Guidelines for Rehabilitating Historic Buildings (other SOI Guidelines may also apply):

Additions

Recommended: Constructing a new addition so that there is the least possible loss of historic materials and so that character-defining features are not obscured, damaged, or destroyed.

Considering the attached exterior addition both in terms of the new use and the appearance of other buildings in the historic district or neighborhood. Design for the new work may be contemporary or may reference design motifs from the historic building.

Locating the attached exterior addition at the rear or on an inconspicuous side of a historic building; and limiting its size and scale in relationship to the historic building.

Designing new additions in a manner that makes clear what is historic and what is new.

Not Recommended: Attaching a new addition so that the character-defining features of the historic building are obscured, damaged, or destroyed.

Designing a new addition so that its size and scale in relation to the historic building are out of proportion, thus diminishing the historic character.

Building Site

Recommended: Identifying, retaining, and preserving buildings and their features as well as features of the site that are important in defining its overall historic character.

Not Recommended: Removing or radically changing buildings and their features or site features which are important in defining the overall historic character of the property so that, as a result, the character is diminished.

From the Ann Arbor Historic District Design Guidelines (other guidelines may apply):

Guidelines for All Additions

Appropriate: Placing a new addition on a non-character-defining or inconspicuous elevation and limiting the size and scale in relationship to the historic property.

Placing new walls in a different plane from the historic structure in a subordinate position to the historic fabric.

Designing a new addition in a manner that makes clear what is historic and what is new.

Limiting the size and scale of the addition in relationship to the historic building so that it does not diminish or visually overpower the building or the district. The addition's footprint should exceed neither half of the original building's footprint nor half of the original building's total floor area.

Not Appropriate: Designing an addition that overpowers or dramatically alters the original building through size or height.

STAFF FINDINGS

1. This house has had a number of post-1944 additions – a large two-story wing to the north, a smaller second floor addition with a south facing gable on top of the historic rear wing, and also single-story additions on the rear. The historic house was 1486 square feet, and the additions are 867.5, or 58% of the original. Because they are already over the 50% guideline, this proposal is to shave 20.3 square feet off of the ground floor of a modern addition and move it to the second-floor rear (again, modern addition) to make that area more usable.
2. Moving floor area from an unused bumpout on the ground floor to the top of a rear bumpout does no harm to the historic structure while making the second floor more usable. The amount of the total floor area being moved is tiny – less than 1%. The roof of the new rear addition would tie in to the original lower gable to the north with a saddle. The saddle and addition are inset from the corner of this original rear wing. New siding would match the existing wood siding.
3. Windows on the modern additions are proposed to be moved, replaced, or added on both side elevations and the rear. A person door with a single full-height lite is proposed to be added on the rear elevation. The windows and door would be Marvin clad Ultimate series. This work is appropriate and does not harm or affect the historic part of the house.
4. There is an existing pair of casement windows in the gable of the rear wing, facing west. This opening is presumed to be non-original since it cuts into the wide board trim on both slopes of the gable. The owners propose to replace the casements with a single double-

hung window in the same opening. This work is appropriate.

5. Staff believes that the work does not have a detrimental effect on historic materials, features or spaces and that the application should be approved.

POSSIBLE MOTIONS: (Note that the motion below is only a suggestion. The Review Committee, consisting of staff and at least two Commissioners, will meet with the applicant on site and then make a recommendation at the meeting.)

I move that the Commission issue a certificate of appropriateness for the application at 520 Sixth Street, a contributing property in the Old West Side Historic District, to: construct a 20 square foot rear second-floor addition on a modern addition; remove a 20 square foot bump out on the north elevation; alter and add windows on the modern additions; remove a modern chimney; and replace a non-original pair of casement windows on the historic portion of the house with a single one-over-one window in the same opening; as proposed. The work is compatible in exterior design, arrangement, materials, and relationship to the building and the surrounding area and meets *The City of Ann Arbor Historic District Design Guidelines* for additions, and *The Secretary of the Interior's Standards for Rehabilitation and Guidelines for Rehabilitating Historic Buildings*, in particular standards 1, 2, 5, 9 and 10, and the guidelines for additions and building site.

MOTION WORKSHEET

I move that the Commission issue a Certificate of Appropriateness for the work at 520 Sixth Street in the Old West Side Historic District

_____ Provided the following condition(S) is (ARE) met: 1) STATE CONDITION(s)

The work is generally compatible with the size, scale, massing, and materials and meets the Secretary of the Interior's Standards for Rehabilitation, standard(S) number(S) (*circle all that apply*): 1, 2, 3, 4, 5, 6, 7, 8, 9, 10

ATTACHMENTS: application, letter, drawings, photos, window details

520 Sixth Street (2008 Survey Photos)





HISTORIC DISTRICT COMMISSION

PLANNING AND DEVELOPMENT SERVICES

City Hall: 301 E. Huron St. Ann Arbor, MI 48104-6120
 Mailing: P.O. Box 8647, Ann Arbor, MI 48107-8647
 Phone: 734.794.6265 ext. 42608 jthacher@a2gov.org
 Fax: 734.994.8460

| OFFICE USE ONLY | |
|-----------------|-------------|
| Permit Number | HDC# _____ |
| | BLDG# _____ |
| DATE STAMP | |
| | |

APPLICATION MUST BE FILLED OUT COMPLETELY

| PROPERTY LOCATION/OWNER INFORMATION | | | |
|--|--|--|--------------------------|
| NAME OF PROPERTY OWNER LUKE RODENORST AND LILLY CONIVETT | | HISTORIC DISTRICT OWS | |
| PROPERTY ADDRESS 520 6TH STREET | | | CITY ANN ARBOR |
| ZIPCODE 48103 | DAYTIME PHONE NUMBER (440) 8218294 | EMAIL ADDRESS luke.rodenorst@gmail.com | |
| PROPERTY OWNER'S ADDRESS (IF DIFFERENT FROM ABOVE) | | CITY | STATE, ZIP |

| PROPERTY OWNER'S SIGNATURE | | |
|----------------------------|---|-----------------------------|
| SIGN HERE | PRINT NAME LUKE RODENORST | DATE 08/05/21 |

| APPLICANT INFORMATION | | | |
|---|---------|-----------------------|---------------|
| NAME OF APPLICANT (IF DIFFERENT FROM ABOVE) | | | |
| ADDRESS OF APPLICANT | | | CITY |
| STATE | ZIPCODE | PHONE / CELL # () | FAX No () |
| EMAIL ADDRESS | | | |

| APPLICANT'S SIGNATURE (if different from Property Owner) | | |
|--|----------------------------|-------------|
| SIGN HERE | PRINT NAME X | DATE |

| BUILDING USE - CHECK ALL THAT APPLY | | | | | |
|---|---------------------------------|---------------------------------|--|-------------------------------------|--|
| <input checked="" type="checkbox"/> SINGLE FAMILY | <input type="checkbox"/> DUPLEX | <input type="checkbox"/> RENTAL | <input type="checkbox"/> MULTIPLE FAMILY | <input type="checkbox"/> COMMERCIAL | <input type="checkbox"/> INSTITUTIONAL |

| PROPOSED WORK |
|---|
| Describe in detail each proposed exterior alteration, improvement and/or repair (use additional paper, if necessary). MORE DETAIL TO FOLLOW INCLUDING COVER LETTER, ARCHITECTURAL DRAWINGS AND PHOTOS. At a high level, we're trading space from a new addition. No historic parts of the house will be impacted. Only new additions will be changed. |

| DESCRIBE CONDITIONS THAT JUSTIFY THE PROPOSED CHANGES: |
|--|
| Water issues and rotting doors initiated the desire to seek changes |

For Further Assistance With Required Attachments, please visit www.a2gov.org/hdc



HISTORIC DISTRICT COMMISSION APPLICATION

| FEE CHART | |
|--|---------------------|
| DESCRIPTION | |
| STAFF REVIEW FEES | FEE |
| Application for Staff Approval | \$35.00 |
| Work started without approvals | Additional \$50.00 |
| HISTORIC DISTRICT COMMISSION FEES | |
| All other proposed work not listed below | \$100.00 |
| Work started without approvals | Additional \$250.00 |
| RESIDENTIAL – Single and 2-story Structure | |
| Addition: single story | \$300.00 |
| Addition: taller than single story | \$550.00 |
| New Structure - Accessory | \$100.00 |
| New Structure – Principal | \$850.00 |
| Replacement of single and 2-family window(s) | \$100 + \$25/window |
| COMMERCIAL – includes multi-family (3 or more unit) structures | |
| Additions | \$700.00 |
| Replacement of multi-family and commercial window (s) | \$100 + \$50/window |
| Replacement of commercial storefront | \$250.00 |
| DEMOLITION and RELOCATION | |
| Demolition of a contributing structure | \$1000.0 |
| Demolition of a non-contributing structure | \$250.00 |
| Relocation of a contributing structure | \$750.00 |
| Relocation of a non-contributing structure | \$250.00 |

FOR COMMISSION REVIEWS:

- Application withdrawals made before public notice is published will qualify for a 50% refund of the application fee.
- Application withdrawals made after public notice is sent but before the public hearing will qualify for a 25% refund of the application fee.

INSTRUCTIONS FOR SUBMITTING APPLICATIONS

All HDC applications must be signed by the property owner and the applicant, if different, with the exception of staff approvals, which may be signed by only the applicant.

All completed HDC applications and their attachments may be submitted to Planning and Development Services by mail, in person (paper or digital), faxed, or via email to building@a2gov.org.

We accept CASH, CHECK, and all major credit cards. Checks should be made payable to "City of Ann Arbor"

HDC applications that are incomplete or not submitted with the required documentation or payment will not be processed or approved.

APPLICATION EXPIRATION

HDC applications expire three (3) years after the date of approval.

OFFICE USE ONLY

| | | |
|------------------|--|-------------------------------------|
| Date of Hearing: | | |
| Action | <input type="checkbox"/> HDC COA | <input type="checkbox"/> HDC Denial |
| | <input type="checkbox"/> HDC NTP | <input type="checkbox"/> Staff COA |
| Staff Signature | | |
| Comments | | |
| Fee: | \$ _____ | |
| Payment Type | <input type="checkbox"/> Check: # _____ <input type="checkbox"/> Cash <input type="checkbox"/> Credit Card | |

Dear Historic District Committee,

Thank you so much for your consideration. The requested additions / renovations do not touch anything historic and only deal with additions that occurred in the 1990s and 2000s. The one request that does touch a historic part of the house is replacing a casement window that is not original or historic in the wing in the south west corner of the house.

When we noticed water damage on the ceiling above the breakfast nook and holes from rot in the westward facing doors (all part of a 1990's addition), we knew we had to do something to address these fundamental issues. This was the original goal behind this application, but given that we were going to need to make these changes, we started to explore what else might be possible without touching the original part of the house.

After multiple conversations with Jill Thatcher ahead of submitting this application, here are the details of the project. Please see the attached architectural renderings of each of these items to compliment this overview.

In order to stay within HDC guidelines, we are asking to trade 1st floor space from an addition to add 2nd floor space over the water damaged area. Both areas are part of the same 1990's addition. Here's the math behind the trade in space as calculated by architect Mary Kalmes:

| | | | |
|-------------|------------|---------|----------------|
| 1947 house: | 1st floor= | 837 sf | (50%=418.5 sf) |
| | 2nd floor= | 649 sf | (50%=324.5 sf) |
| | Total | 1486 sf | (50%=743 sf) |

There have been several additions to the first and second floors. Calculations for the new totals are as follows:

1st floor additions: Family room= 334.5, Pool room=168, Mudroom=45.
Total=547.5.
 $547.5-418.5= 129$ sf over 50%

2nd floor additions: east bedroom=48, NW bedroom=272.
Total=320.
 $324.5-320= 4.5$ sf under 50%.

In the renovation, we would be trading out the first floor north facing fireplace bump out (20.3 SF) for the second floor addition over the leaking door wall area (20.3 SF). See floor plans below that show the first floor demo and where we'd be adding that traded space onto the second floor.

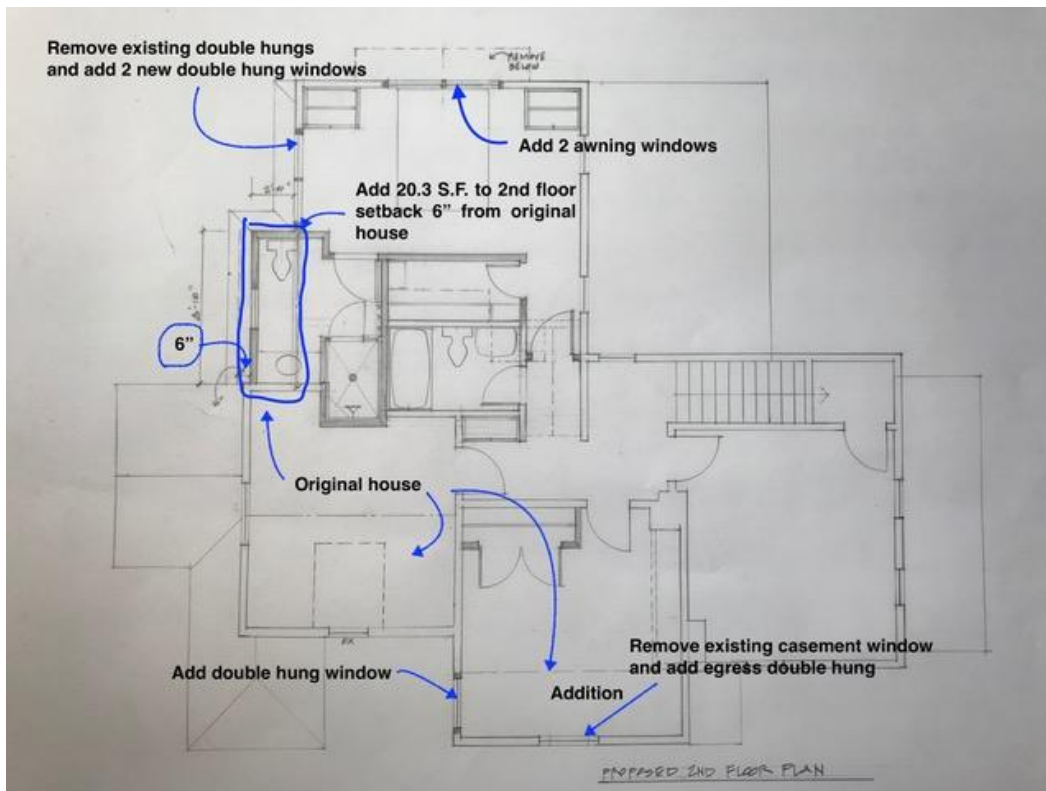
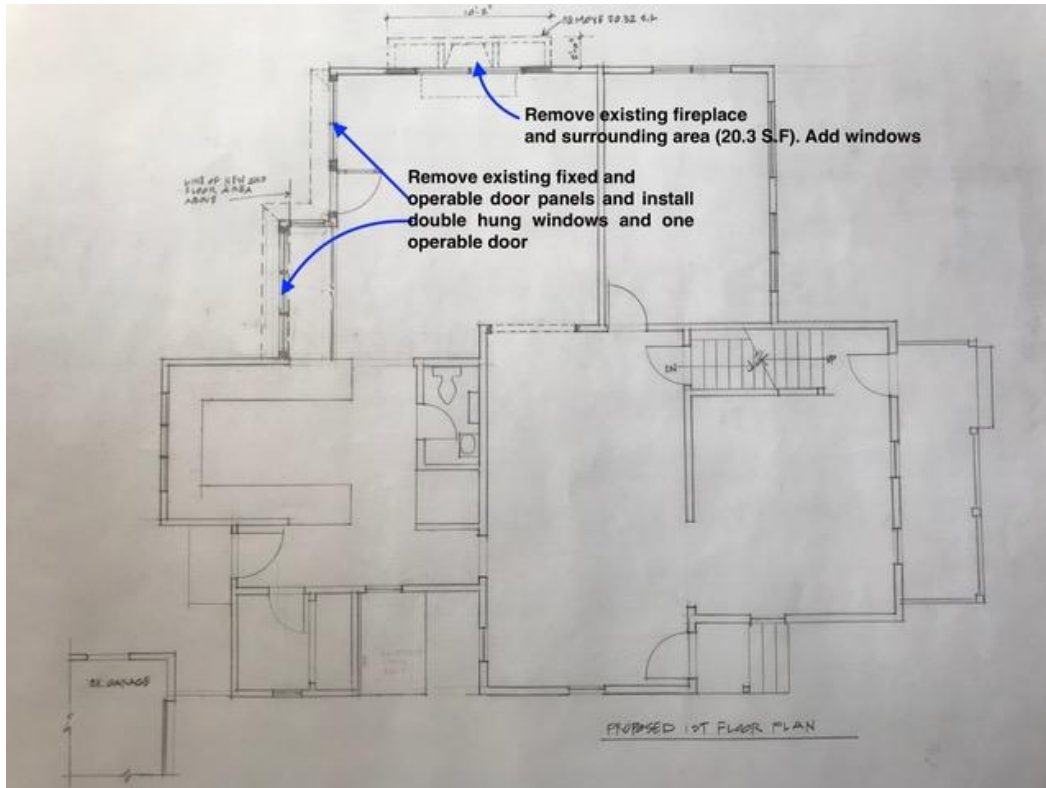

North Elevation: The demo of the first floor fireplace bump out would allow us to put new windows on the north side of the first floor and second floors.

All windows and door clad Marvin Ultimate series

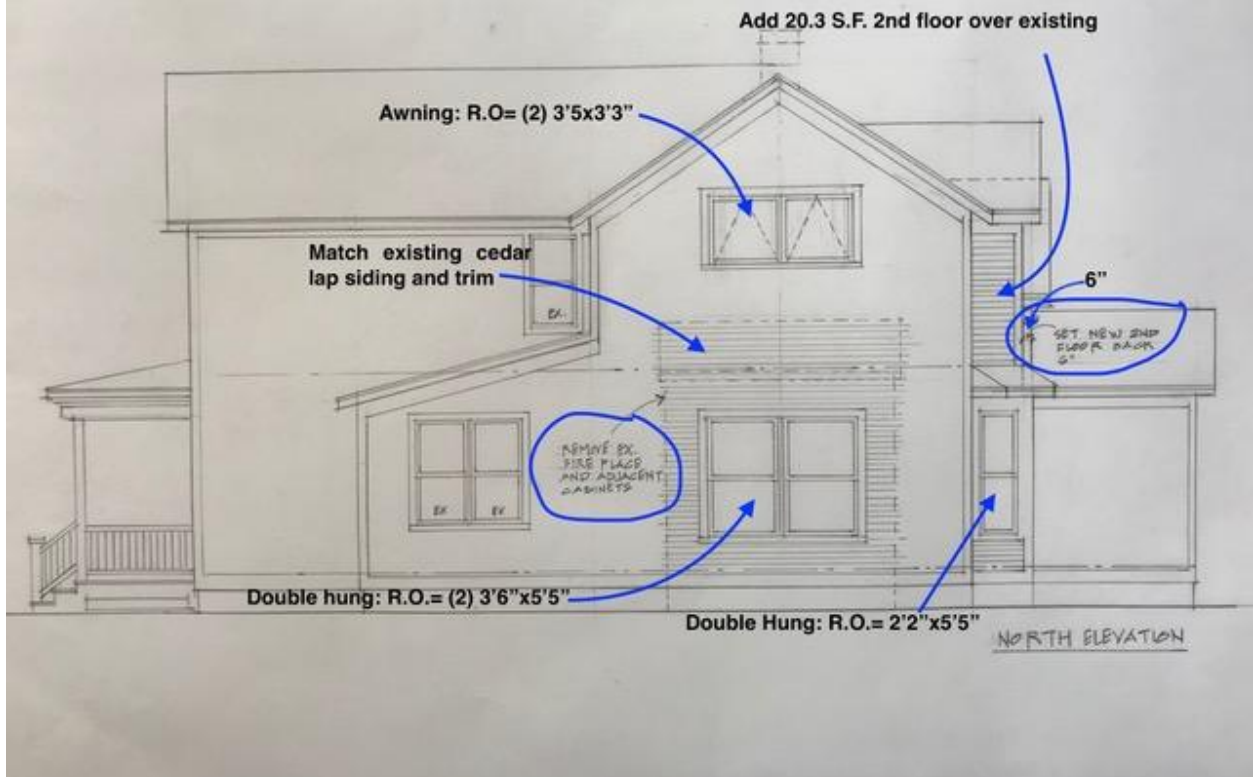

West Elevation: We plan on replacing all of the rotting doors lining the west facing part of the house (all part of the 1990's addition) and replace with double hung windows and one door for access to the deck. We will also be replacing the existing NW 2nd floor windows (part of the 1990's addition) and adding a double hung window to the SW bedroom (part of a 2000 addition).

The only historic/original area of the house where we are requesting a change, is to replace a casement window (which may have replaced an original in the 2000's), in the southwest wing on the second floor with a single double hung egress casement. Here's the drawing of what this would look like.

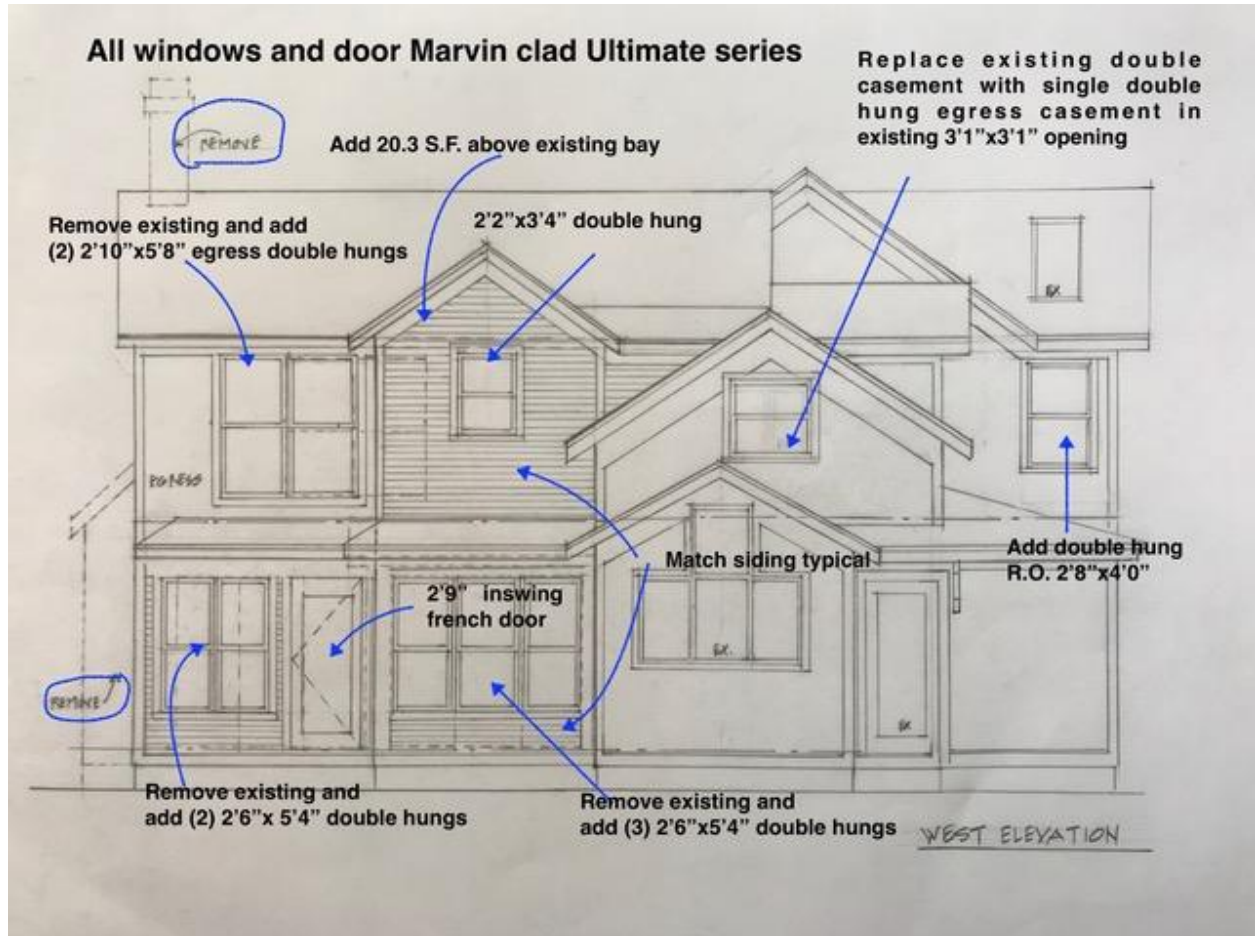

South Elevation: Lastly, we would like to replace another window, that was a part of the 2000 addition, on the south facing bump out on the second floor.

All windows and door Marvin clad Ultimate series



Thank you for your consideration!

Luke Rodehorst and Lilly Connett

Other Photos:

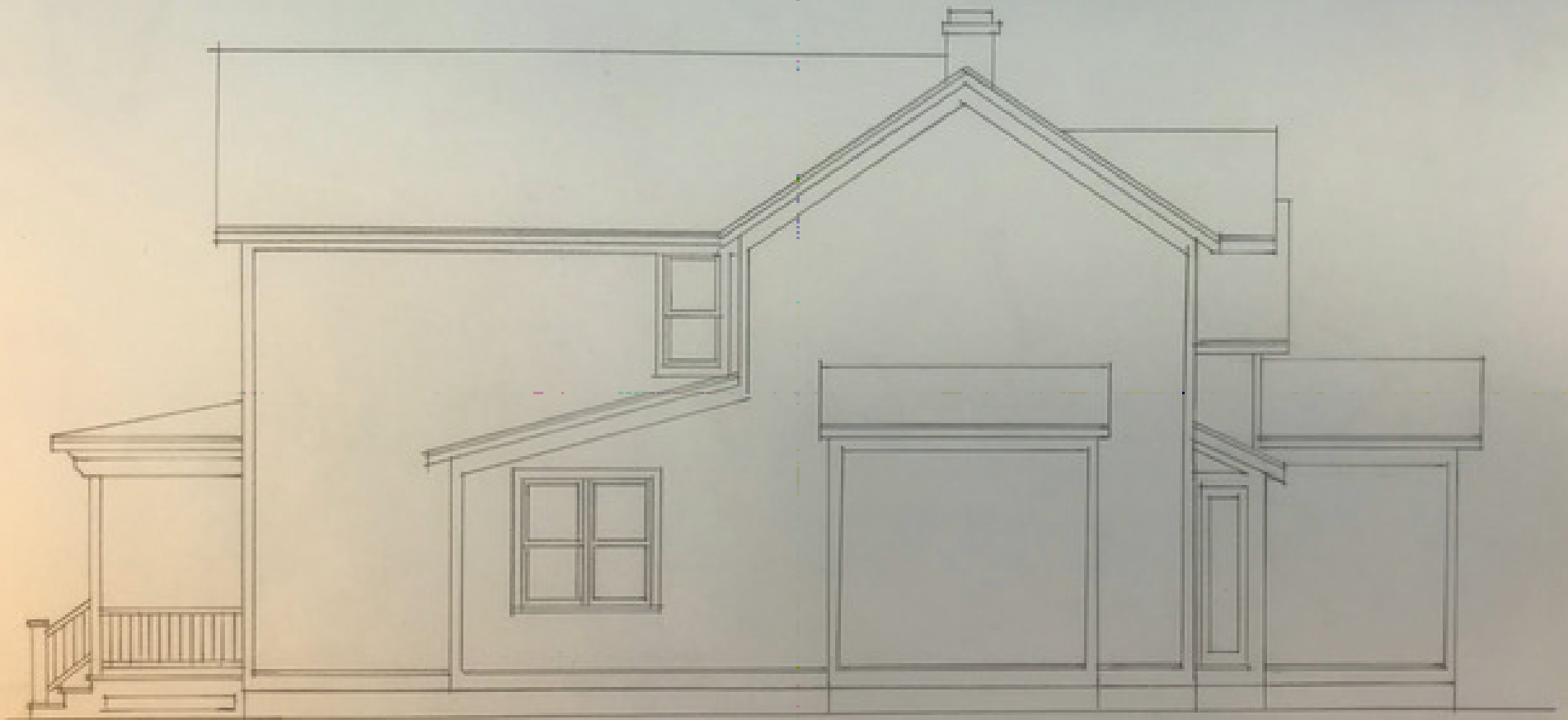

EXISTING NORTH ELEVATION



EXISTING WEST ELEVATION



SOUTH ELEVATION



Current south facing view. Second floor window to be updated as egress double hung.



Current west view of house.



Close up of rotting west facing doors.



North bump out to be removed.

Section Details: Operating

Scale: 3" = 1' 0"

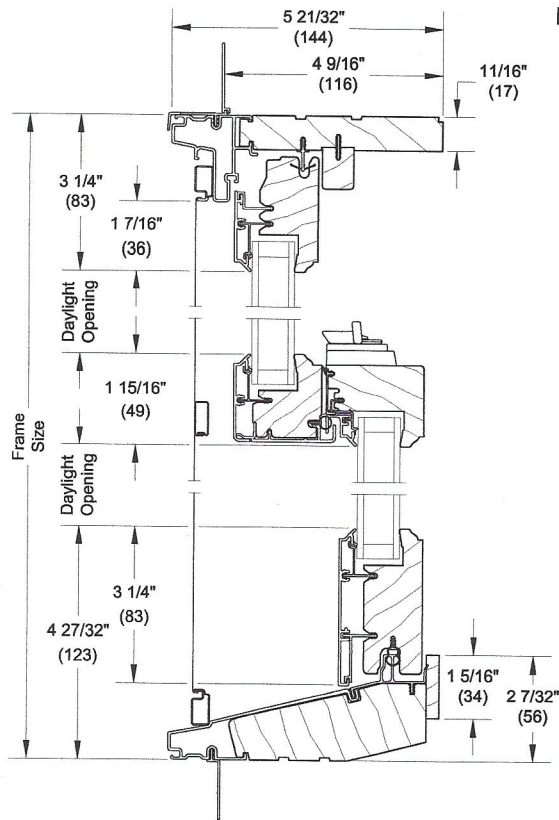

Head Jamb and Sill

Double Hung

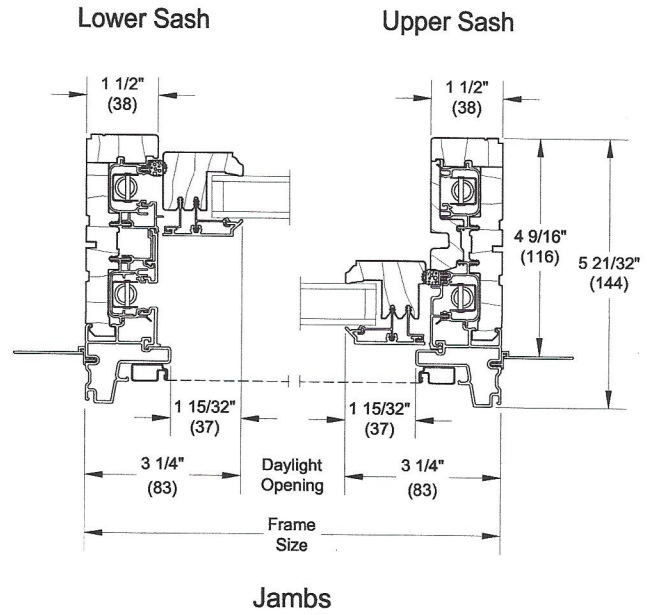

Jambs

Single Hung

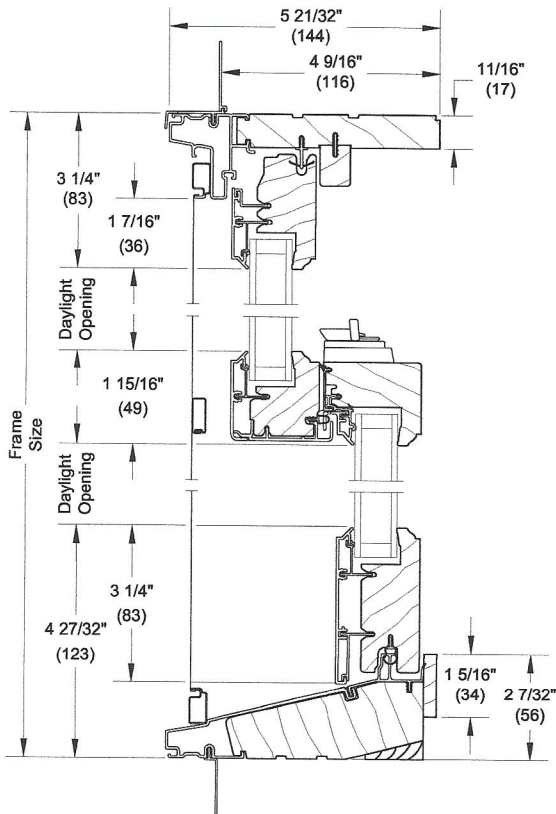

Lower Sash

Upper Sash

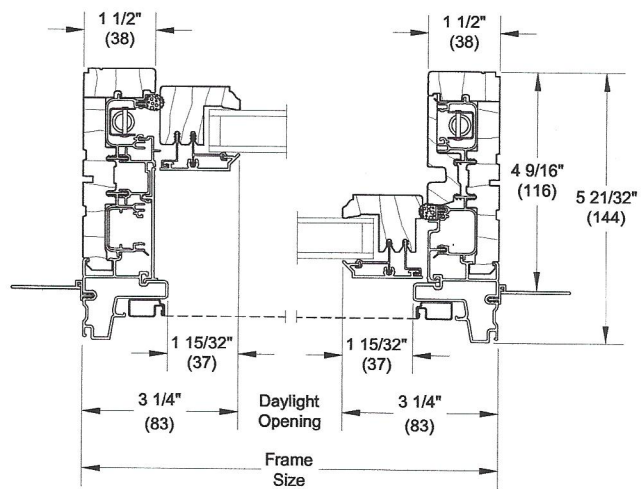

Jambs

Section Details: Operating/Stationary/Picture - 1" (25) IG

Scale: 3" = 1' 0"

Operating

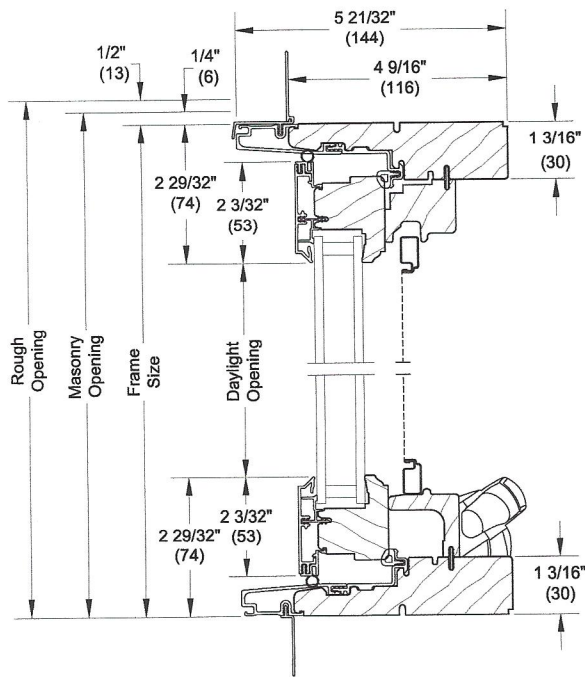

Head Jamb and Sill

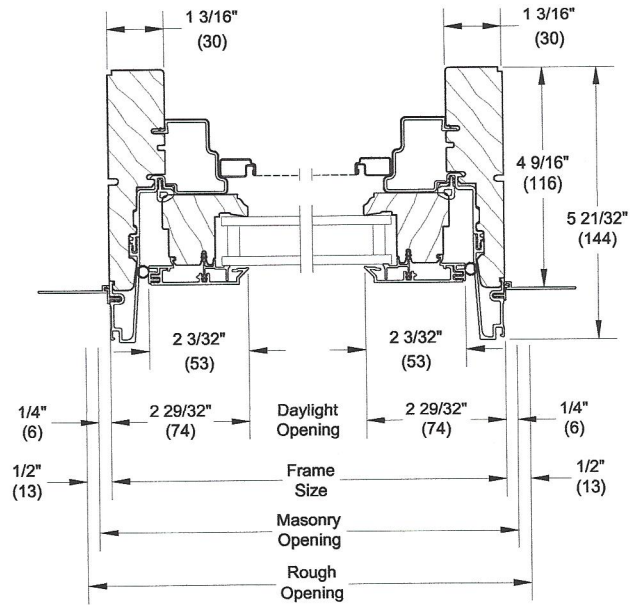

Jambs

Stationary/Picture

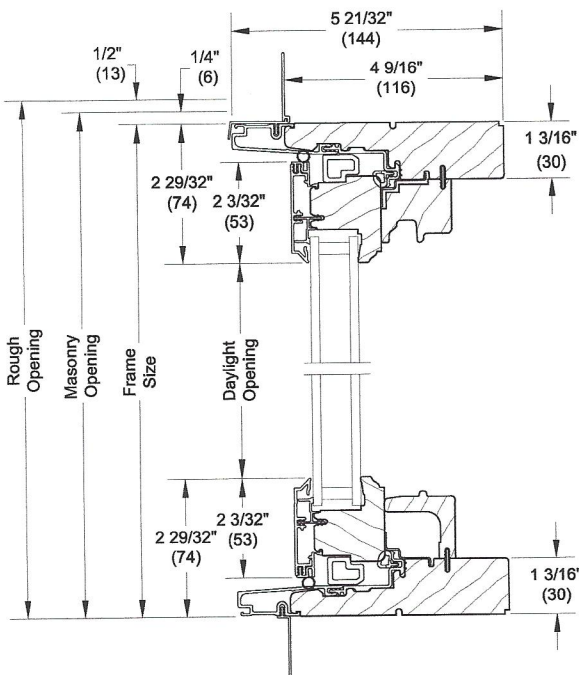

Head Jamb and Sill

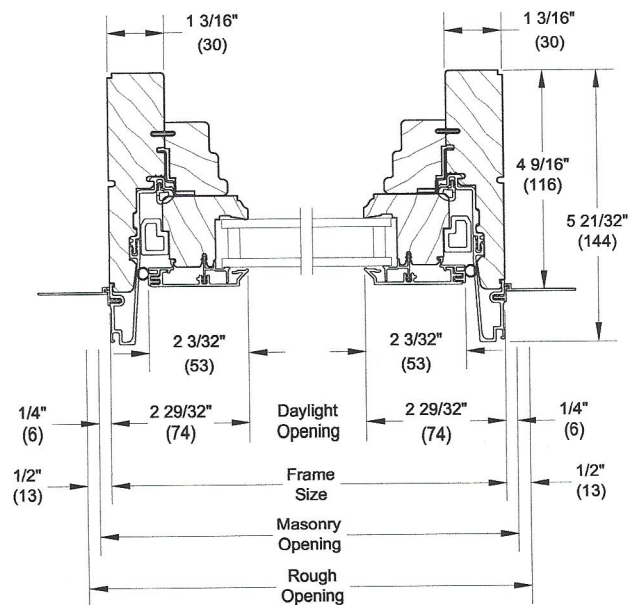

Jambs

Inswing Section Details: Operating (1 3/4" Panels)

Scale: 3" = 1' 0"

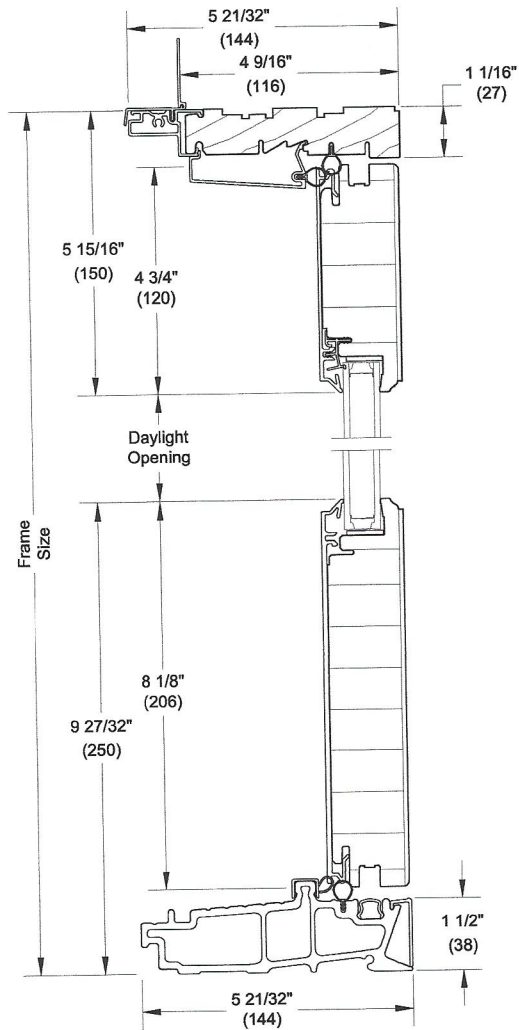

4 9/16" Head Jamb and Sill

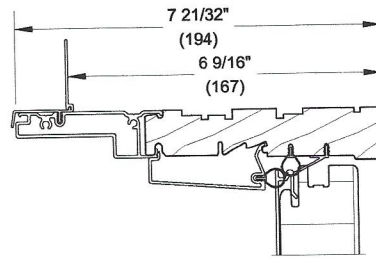

6 9/16" Head Jamb

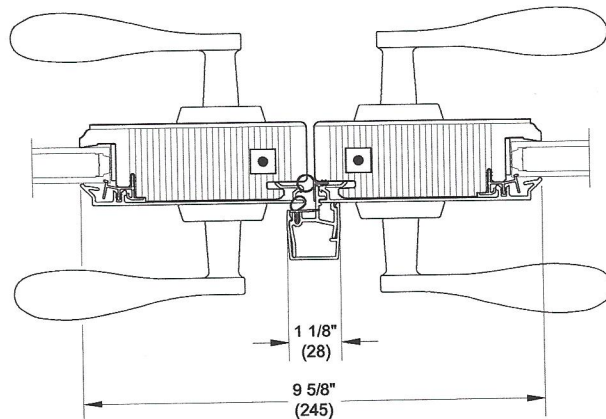

XX L - Meeting Stiles

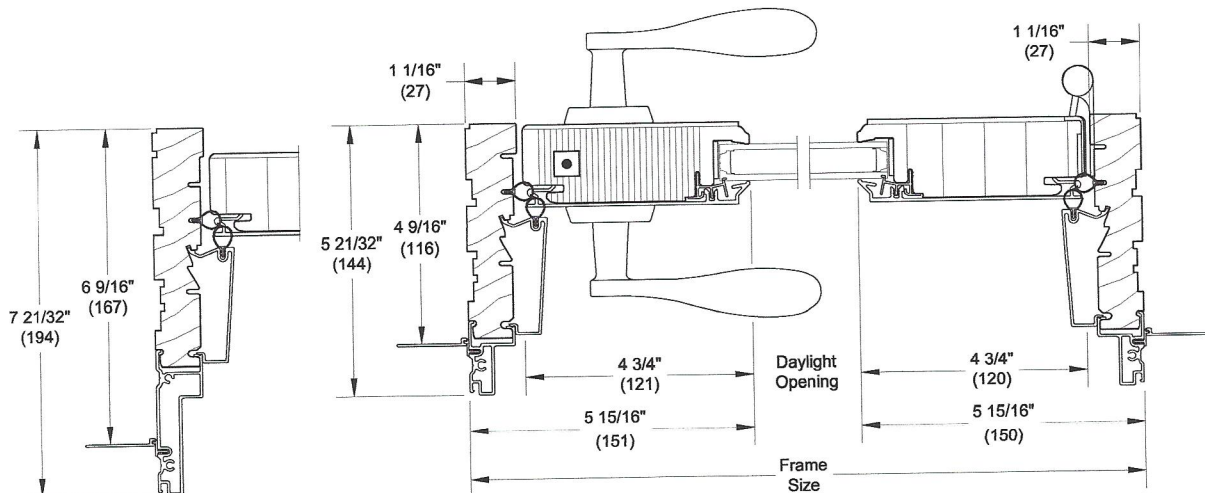

6 9/16" Jamb

4 9/16" X R Jamb