

## ANN ARBOR HISTORIC DISTRICT COMMISSION

### Staff Report

**ADDRESS:** 1310 Hill Street, Application Number HDC16-012

**DISTRICT:** Washtenaw/Hill Historic District

**REPORT DATE:** February 11, 2016

**REPORT PREPARED BY:** Jill Thacher, Historic Preservation Coordinator

**REVIEW COMMITTEE DATE:** Monday, February 8, 2016

#### OWNER

**Name:** Dan Pampreen  
**Address:** 1608 Shadford  
 Ann Arbor, MI  
**Phone:** (734) 891-2970

#### APPLICANT

Robert Burroughs/OX Studio  
 302B S. State Street  
 Ann Arbor, MI  
 (734) 929-9000

**BACKGROUND:** This 1890 Georgian Revival house was first occupied by Edward deMille Campbell, a professor of analytical chemistry and metallurgy, and his family. The front façade's symmetry is notable, particularly the pedimented front gable, window placement, and chimneys at both ends. See the attached study committee report for more information.

In 2009 an application was approved to build a rear addition. That work was never undertaken, and the certificate of appropriateness has expired.

In December, 2015 an application for work already in progress (installation of two egress doors, removal of windows and wall blocks, and installation of mini-splits and line sets) was denied by the Historic District Commission. The work was ordered reversed.

In January, 2016 a staff approval was granted to relocate the mini-splits and reverse the work to the basement wall where double doors had been installed. Also that month, the HDC denied an application to alter the other egress door, on the southeast corner of the house, by installing a replica of the basement window that had been removed above the door and reducing the size of the doorwell.

**LOCATION:** The site is located on the south side of Hill Street, between South Forest and Olivia.

**APPLICATION:** The applicant seeks HDC approval to replace the egress door on the southeast corner of the house with a basement egress window beneath a replica of the historic basement window. The window has a well that is 48"x48", built of the same retaining wall blocks proposed on previous applications, and featuring a single step and a ladder.



## APPLICABLE REGULATIONS:

### From the Secretary of the Interior's Standards for Rehabilitation:

- (2) The historic character of a property shall be retained and preserved. The removal of historic materials or alteration of features and spaces that characterize a property shall be avoided.
- (9) New additions, exterior alterations, or related new construction shall not destroy historic materials that characterize the property. The new work shall be differentiated from the old and shall be compatible with the massing, size, scale, and architectural features to protect the historic integrity of the property and its environment.
- (10) New additions and adjacent or related new construction shall be undertaken in such a manner that if removed in the future, the essential form and integrity of the historic property and its environment would be unimpaired.

### From the Secretary of the Interior's Guidelines for Rehabilitating Historic Buildings (other SOI Guidelines may also apply):

#### Health and Safety

Recommended: Identifying the historic building's character-defining spaces, features, and finishes so that code-required work will not result in their damage or loss.

Complying with health and safety codes, including seismic code requirements, in such a manner that character-defining spaces, features, and finishes are preserved.

Not Recommended: Altering, damaging, or destroying character-defining spaces, features, and finishes while making modifications to a building or site to comply with safety codes.

Making changes to historic buildings without first exploring equivalent health and safety systems, methods, or devices that may be less damaging to historic spaces, features, and finishes.

#### Windows

Recommended: Designing and installing additional windows on rear or other non-character-defining elevations if required by the new use. New window openings may also be cut into exposed party walls. Such design should be compatible with the overall design of the building, but not duplicate the fenestration pattern and detailing of a character-defining elevation.

Not Recommended: Introducing a new design that is incompatible with the historic character of the building.

#### District or Neighborhood Setting

Not Recommended: Introducing new construction into historic districts that is visually incompatible or that destroys historic relationships within the setting.

## From the City of Ann Arbor Design Guidelines:

### Safety Codes

Appropriate: Complying with barrier free and safety codes in a manner that ensures the preservation of character-defining features.

### Windows

Not Appropriate: Changing the number, location, and size or glazing pattern of windows by cutting new openings, blocking-in, or installing replacement sash which does not fit the historic opening.

## STAFF FINDINGS:

1. The proposed egress window is a push-out casement style of aluminum-clad wood. The 48" x 48" well with block retaining walls has one 12" deep step and a ladder to aid in exiting the 60" deep well. The egress window would be mounted below a replica of the historic three-light basement window that was removed. Staff has requested an additional drawing of the elevation view that would show the replica window, egress window, and reinstalled historic cut stone above grade.
2. Configuring the egress window below the basement window results in a deeper well, but better retains the historic appearance of the basement window above grade.
3. Staff feels that the proposed egress window's location, size, and design are appropriate.

**POSSIBLE MOTIONS:** (Note that the motion is only a suggestion. The Review Committee, consisting of staff and at least two Commissioners, will meet with the applicant on site and then make a recommendation at the meeting.)

I move that the Commission issue a certificate of appropriateness for the application at 1310 Hill Street, a contributing property in the Washtenaw/Hill Historic District, to add a basement egress window on the condition that the proposed barrier is secured along the driveway near the street prior to the issuance of building permits. The work is compatible in exterior design, arrangement, texture, material and relationship to the rest of the building and the surrounding area and meets the *Ann Arbor Historic District Design Guidelines*, especially those for windows, and the *Secretary of the Interior's Standards for Rehabilitation* and *Guidelines for Rehabilitating Historic Buildings*, in particular standards 2, 9 and 10 and the guidelines for windows.

**ATTACHMENTS:** application, drawings, window information.



**City of Ann Arbor**  
**PLANNING & DEVELOPMENT SERVICES — PLANNING SERVICES**

301 E. Huron Street | P.O. Box 8647 | Ann Arbor, Michigan 48107-8647  
p. 734.794.6265 | f. 734.994.8312 | [planning@a2gov.org](mailto:planning@a2gov.org)

**ANN ARBOR HISTORIC DISTRICT COMMISSION APPLICATION**

**Section 1: Property Being Reviewed and Ownership Information**

Address of Property: 1310 HILL STREET

Historic District: WASHTENAW / HILL

Name of Property Owner (If different than the applicant):

DAN PAMPREEN

Address of Property Owner: 1608 SHADFORD ANN ARBOR, MI 48104

Daytime Phone and E-mail of Property Owner: (734) 891-2970

Signature of Property Owner:  Date: 01/21/2016

**Section 2: Applicant Information**

Name of Applicant: ROBERT BURROUGHS / OX STUDIO INC.

Address of Applicant: 302B SOUTH STATE STREET ANN ARBOR, MI 48104

Daytime Phone: (734 ) 929-9000 Fax: (734 ) 929-9001

E-mail: ROBB@OXSTUDIOINC.COM

Applicant's Relationship to Property:  owner  architect  contractor  other

Signature of applicant:  Date: 01/21/2016

**Section 3: Building Use (check all that apply)**

Residential  Single Family  Multiple Family  Rental

Commercial  Institutional

**Section 4: Stille-DeRossett-Hale Single State Construction Code Act**

(This item **MUST BE INITIALED** for your application to be **PROCESSED**)

Public Act 169, Michigan's Local Historic Districts Act, was amended April 2004 to include the following language: "...the applicant has certified in the application that the property where the work will be undertaken has, or will have before the proposed completion date, a a fire alarm or smoke alarm complying with the requirements of the Stille-DeRossett-Hale Single State Construction Code Act, 1972 PA 230, MCL 125.1501 to 125.1531."

Please initial here: \_\_\_\_\_

**Section 5: Description of Proposed Changes (attach additional sheets as necessary)**

1. Provide a brief summary of proposed changes. \_\_\_\_\_

RESTORATION OF PREVIOUS WORK DONE ON THE SITE AND ADDITION OF NEW EGRESS WINDOW AND WINDOW WELL FOR EGRESSING PURPOSES. THE EXISTING BASEMENT WINDOW WILL BE REINSTALLED (OR REPLACED IN KIND IF DAMAGES OR IRREPERABLE) AND EXISTING CUT STONE EXPOSED FOUNDATION WILL BE REINSTALLED TO BRING VISIBLE BACK TO ORIGINAL STATE. A NEW EGRESS WINDOW AND EGRESS WELL WILL BE INSTALLED.

2. Provide a description of existing conditions. \_\_\_\_\_

WINDOW WAS REMOVED ALONG WITH CUT STONE AND COBBLE FOUNDATION WALL. A CONTEMPORARY EGRESS IS PRESENTLY INSTALLED IN PLACE OF EXISTING COBBLE FOUNDATION SYSTEM. AREA HAS BEEN ROUGH GRADED TO EXTENTS OF LOWER LEVEL AND PORTIONS OF A CONTEMPORARY RETAINING WALL SYSTEM INSTALLED.

3. What are the reasons for the proposed changes? \_\_\_\_\_

TO RESTORE CONDITIONS BACK TO ORIGINAL STATE AND TO LIKEWISE PROVIDE A SECONDARY MEANS OF EGRESS FROM THE BASEMENT LEVEL. NEW WORK SHALL BE APPROPRIATELY SCREENED BELOW GRADE AND VIA PERIMETER LANDSCAPING.

4. Attach any additional information that will further explain or clarify the proposal, and indicate these attachments here.

FLOOR PLAN, SECTION THRU THE WELL AND PROPOSED WINDOW ARE ATTACHED FOR REFERENCE.

5. Attach photographs of the existing property, including at least one general photo and detailed photos of proposed work area.

**STAFF USE ONLY**

Date Submitted: \_\_\_\_\_ Application to \_\_\_\_\_ Staff or \_\_\_\_\_ HDC

Project No.:     HDC     Fee Paid: \_\_\_\_\_

Pre-filing Staff Reviewer & Date: \_\_\_\_\_ Date of Public Hearing: \_\_\_\_\_

Application Filing Date: \_\_\_\_\_ Action: \_\_\_\_\_ HDC COA \_\_\_\_\_ HDC Denial

Staff signature: \_\_\_\_\_ \_\_\_\_\_ HDC NTP \_\_\_\_\_ Staff COA

Comments:



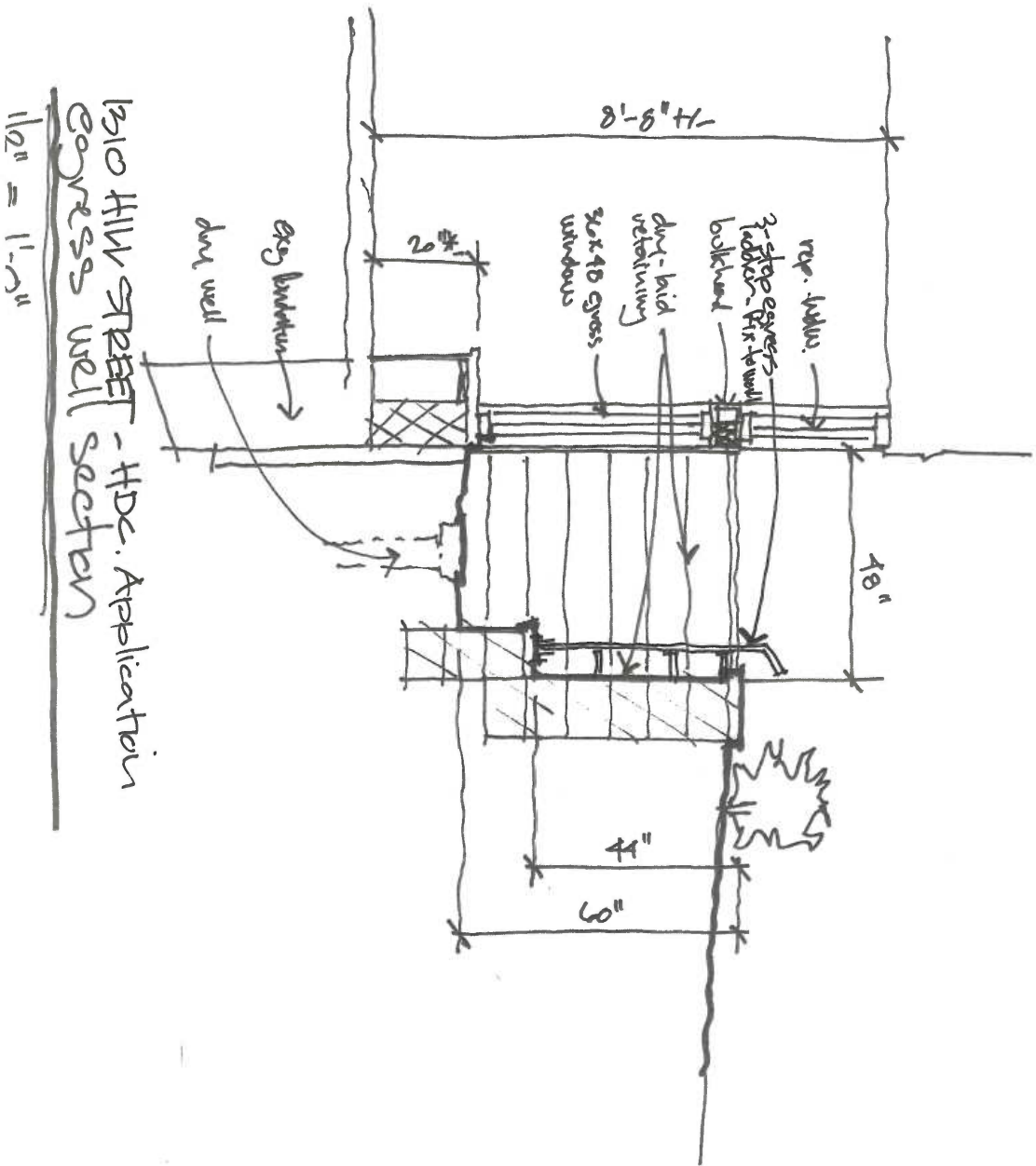

OK STAFF, NC  
01/21/2016

1310 HILW STREET - HDX Application  
Egress Well plan  
1/2" = 1'-0"

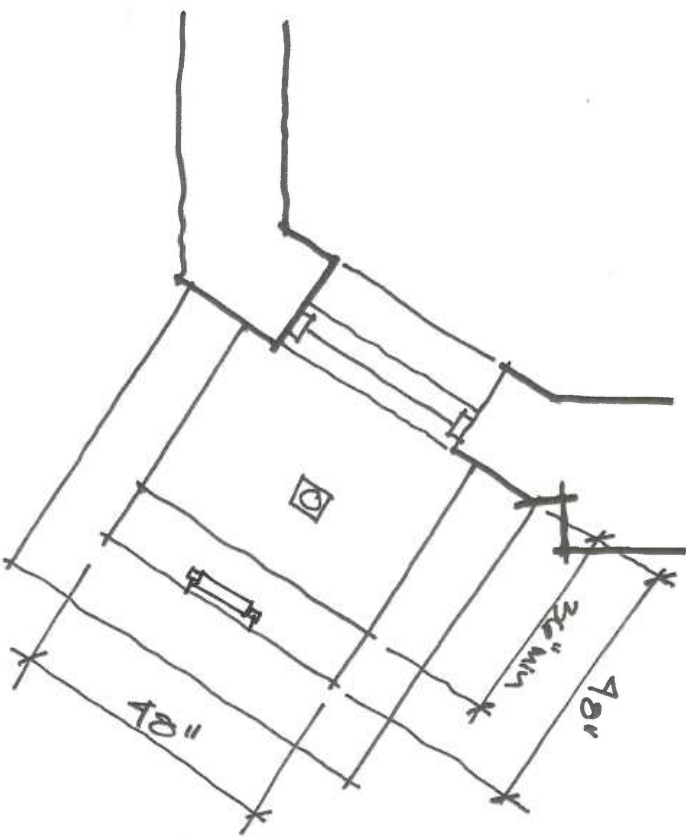

OK STUDIO, INC.  
01/21/2016

## CASEMENT WINDOWS

This clean, modern design is a simple and beautiful way to accent different rooms in your home in addition to maximizing ventilation. This type of window can be hinged on either the left or right so that the sash opens outward in a swinging motion. The streamlined design of the profile detail complements historic, traditional, Craftsman and contemporary architecture.

A great choice for new construction or replacement, JELD-WEN® casement windows offer multiple sizes, colors and glass options. See dealer for additional product details and ordering information.

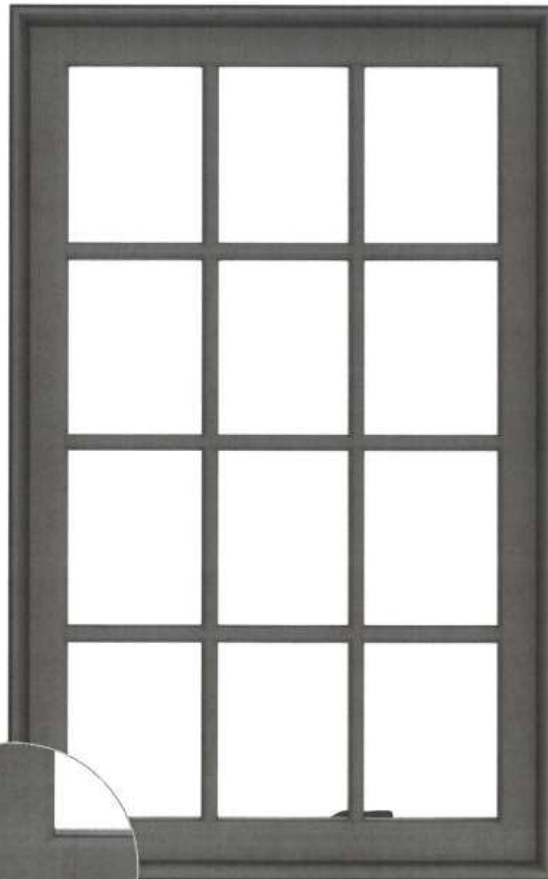

Streamlined profile complements a variety of architectural styles.



# PUSH-OUT CASEMENT AND AWNING WINDOWS

Simplicity is at the core of these stylish window options. They open like our other casement windows (hinged at the side) and awning windows (hinged at the top) yet they do so without a hardware crank. Just unlatch the lock to open for ventilation.

### SWINGING SCREEN

Historically detailed swinging screen matches wood and hardware finishes

### PUSH-OUT HANDLE

Simple and secure, this handle is reminiscent of old world charm but with the added benefits of modern security

### HIDDEN MAGNETIC CLOSURES

For a clean unobstructed look.



Clean lines, proven operation and multiple options for screens, finishes and hardware make these windows a great choice for your home. See dealer for additional product details and ordering information.

## CASEMENT AND AWNING HIGH PERFORMANCE FEATURES

Our goal of achieving a window design that meets the 2016 ENERGY STAR® 6 criteria has allowed us to take advantage of the latest in high performance engineering and design. The new Sitaline design includes heavier hardware and greater thermal performance. The traditional putty glaze and deeper set sash features give this window an architecturally enriched appearance that works well in modern, historical, new construction, historical renovation and light commercial.

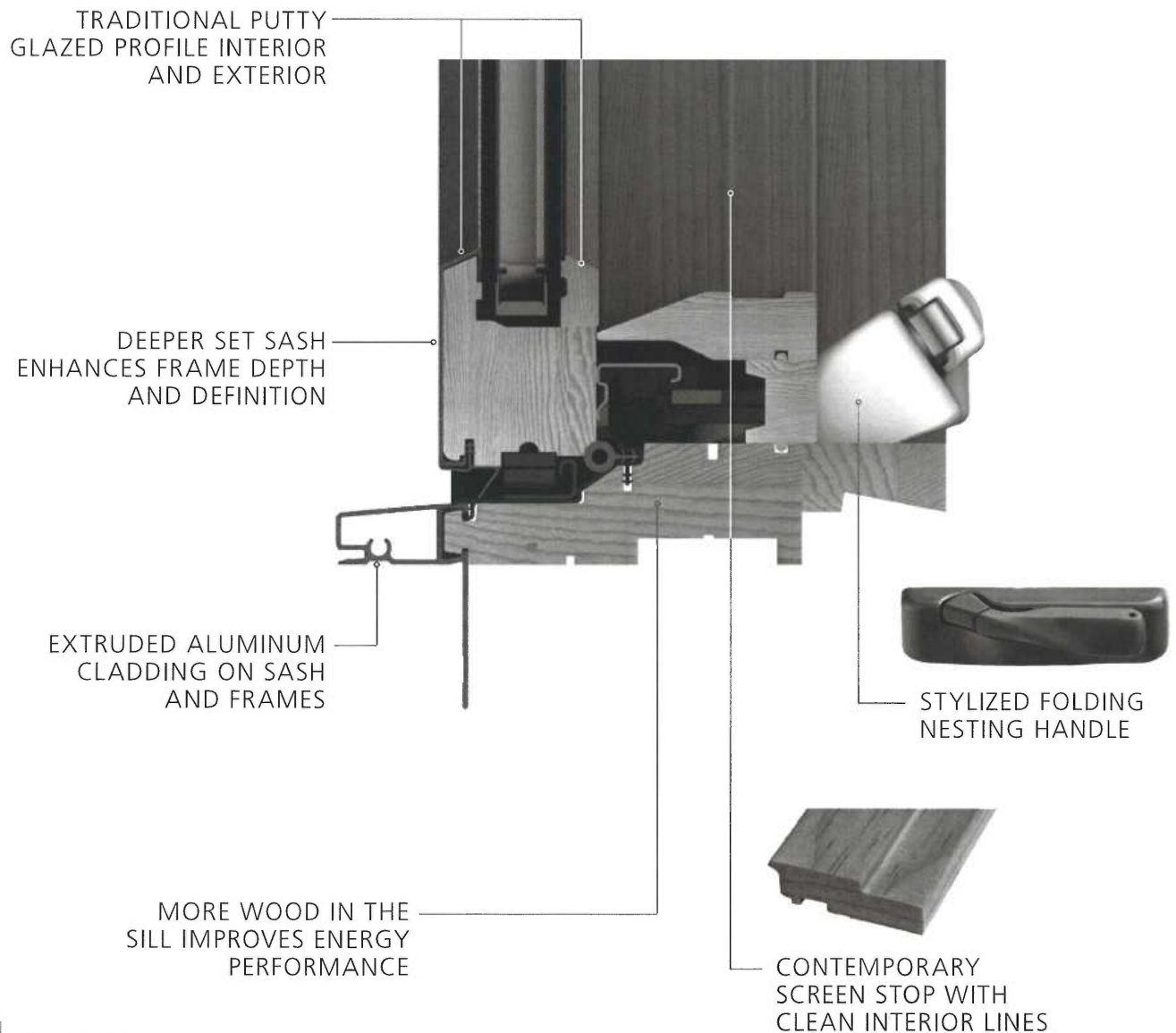

**UNIT SIZING, ROUGH OPENING,  
MASONRY OPENINGS**

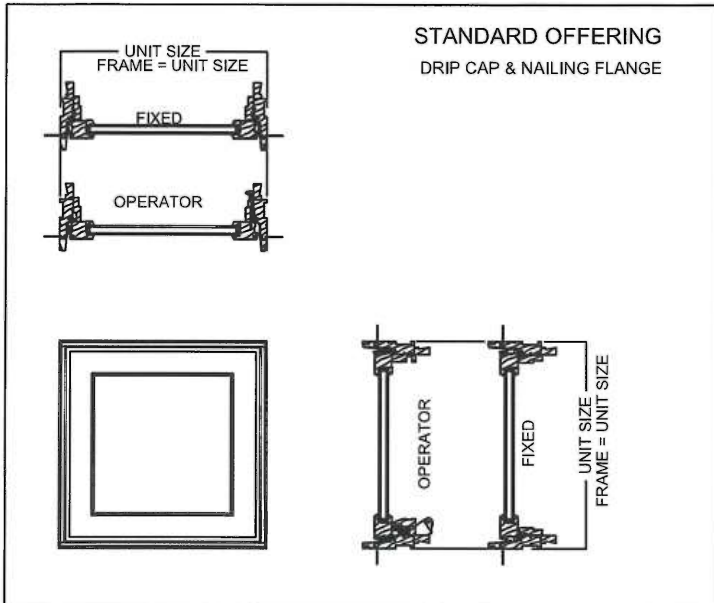

**GENERAL NOTES:**

UNIT SIZE IS ALWAYS THE  
EXTREME SIZE OF THE WINDOW  
WITH OR WITHOUT TRIM AND  
DOES NOT INCLUDE NAIL FIN

**MASONRY OPENING:**

MASONRY OPENING IS ALWAYS 1/2" OVER (HEIGHT AND WIDTH)  
THE UNIT SIZE OR THE OUTSIDE EDGE OF THE TRIM  
OF THE WINDOW

**ROUGH OPENING:**

ROUGH OPENING IS ALWAYS 3/4" OVER  
FRAME SIZE OF THE WINDOW

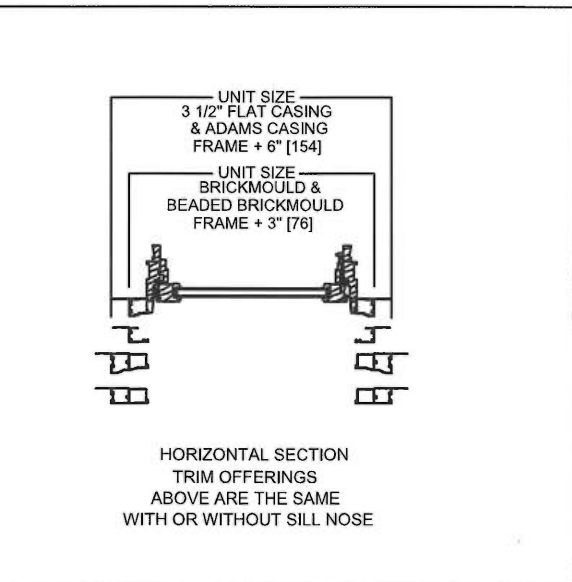
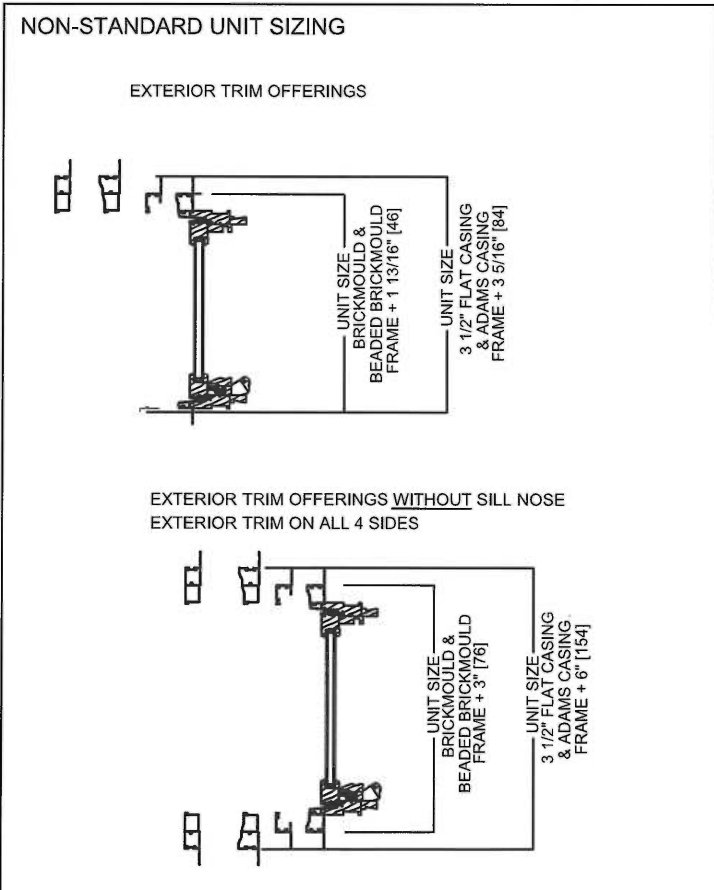
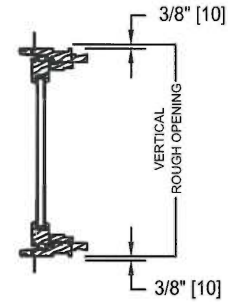
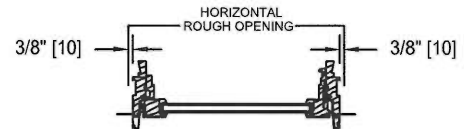

TRIM OPTIONS

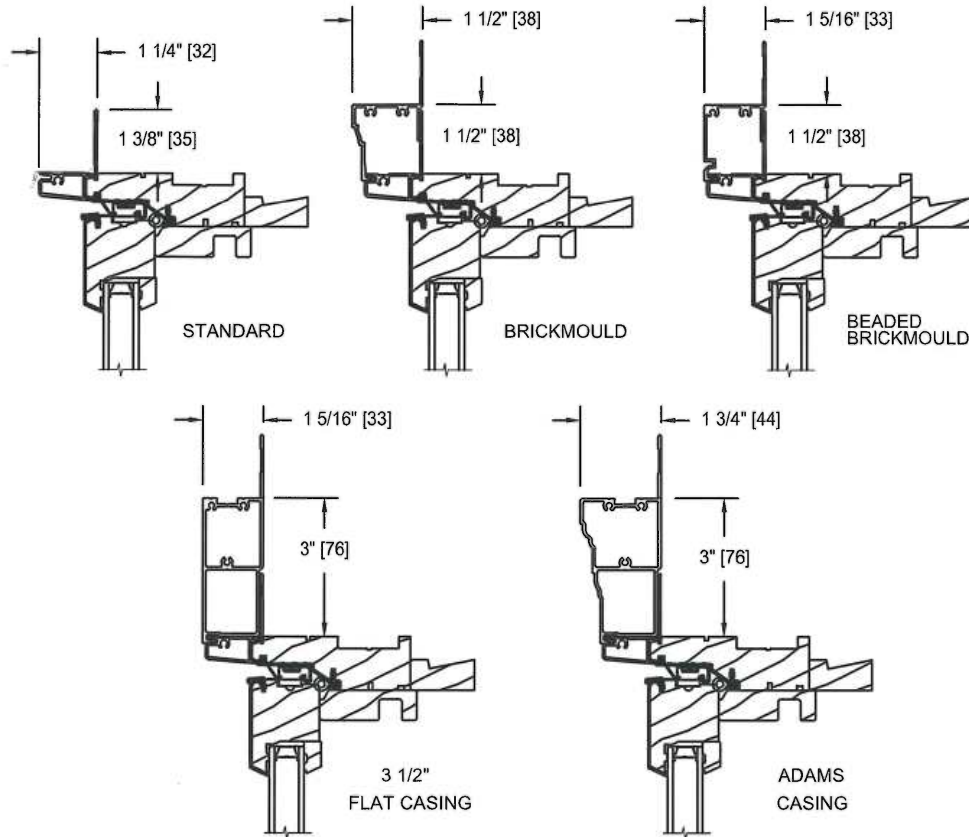

SILL NOSE OPTIONS

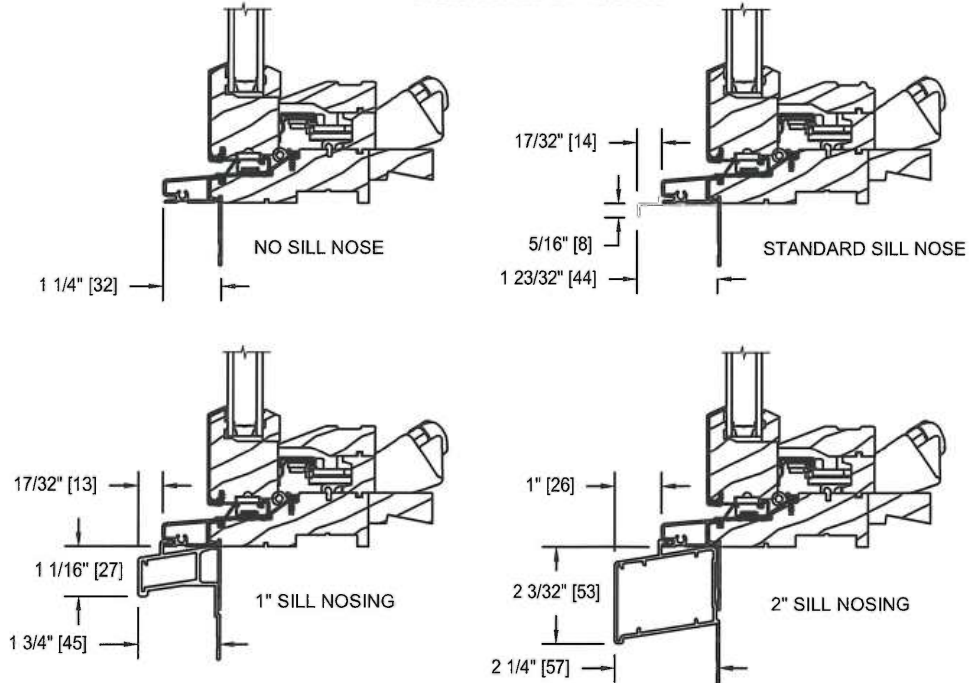

HANDING AND OPERATION

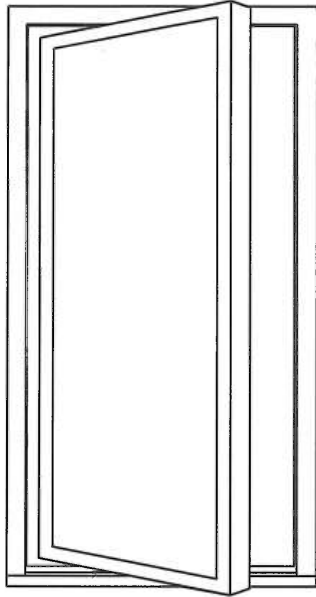

LEFT  
HAND

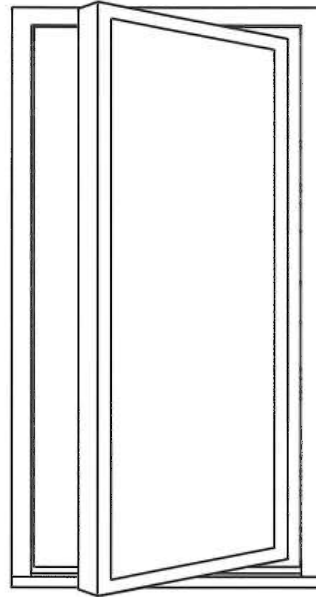

RIGHT  
HAND

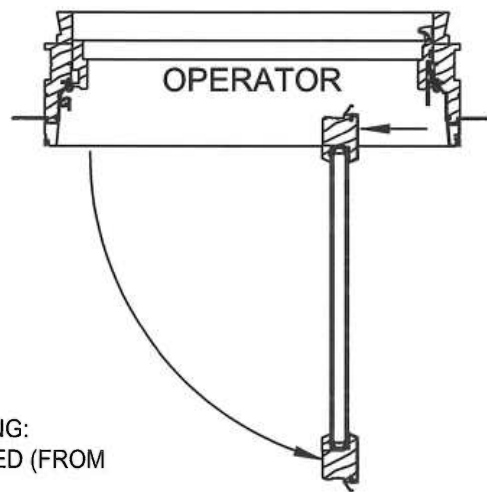
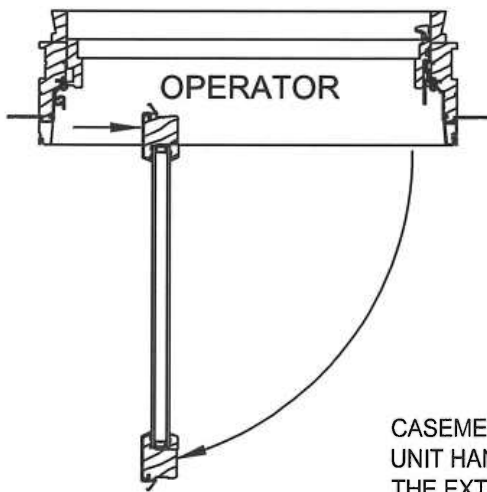

CASEMENT UNIT HANDING:  
UNIT HANDING IS DEFINED (FROM  
THE EXTERIOR) AS THE  
DIRECTION THE SASH OPENS.

---

GLASS STOP OPTIONS

---

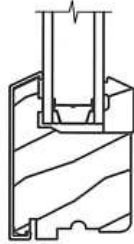

TRADITIONAL

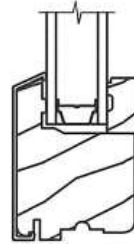

CONTEMPORARY



### SINGLE UNIT ELEVATIONS

M.O. BRICKMOUND 21 1/2"(546)  
M.O. ADAMS/FLAT CASING 24 1/2"(645)  
ROUGH OPENING 18 3/4"(476)  
FRAME SIZE 18"(457)  
DAYLIGHT OPENING 12 1/8"(308)

23 1/2"(597)  
26 1/2"(673)  
20 3/4"(527)  
20"(508)  
14 1/8"(359)

27 1/2"(699)  
30 1/2"(775)  
24 3/4"(629)  
24"(610)  
18 1/8"(460)

31 1/2"(800)  
34 1/2"(876)  
28 3/4"(730)  
28"(711)  
22 1/8"(562)

33 1/2"(851)  
36 1/2"(927)  
30 3/4"(781)  
30"(762)  
24 1/8"(613)

35 1/2"(902)  
38 1/2"(978)  
32 3/4"(832)  
32"(813)  
26 1/8"(664)

39 1/2"(1003)  
42 1/2"(1080)  
36 3/4"(933)  
36"(914)  
30 1/8"(765)

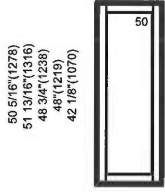

SCC1848  
SCPOC1848



SCC2048  
SCPOC2048



SCC2448  
SCPOC2448

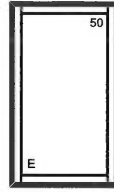

SCC2848  
SCPOC2848

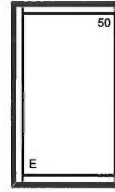

SCC3048  
SCPOC3048

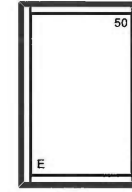

SCC3248  
SCPOC3248

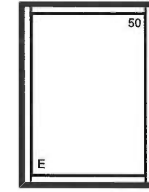

SCC3648  
SCPOC3648

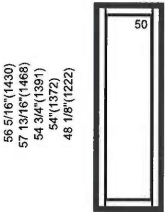

SCC1854  
SCPOC1854



SCC2054  
SCPOC2054

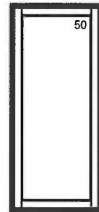

SCC2454  
SCPOC2454

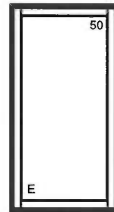

SCC2854  
SCPOC2854

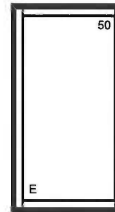

SCC3054  
SCPOC3054



SCC3254  
SCPOC3254

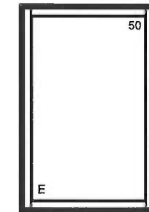

SCC3654  
SCPOC3654

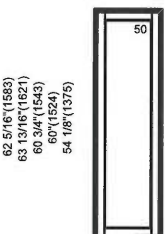

SCC1860  
SCPOC1860



SCC2060  
SCPOC2060



SCC2460  
SCPOC2460



SCC2860  
SCPOC2860

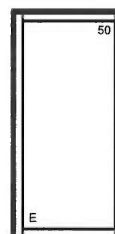

SCC3060  
SCPOC3060



SCC3260  
SCPOC3260

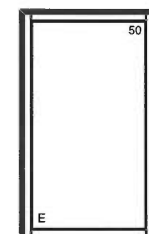

SCC3660  
SCPOC3660

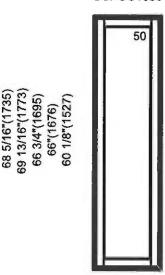

SCC1866  
SCPOC1866



SCC2066  
SCPOC2066



SCC2466  
SCPOC2466

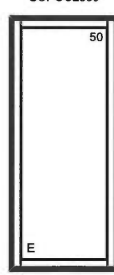

SCC2866  
SCPOC2866



SCC3066  
SCPOC3066



SCC3266  
SCPOC3266

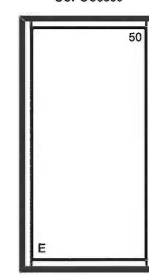

SCC3666  
SCPOC3666



SCC1872  
SCPOC1872



SCC2072  
SCPOC2072



SCC2472  
SCPOC2472



SCC2872  
SCPOC2872

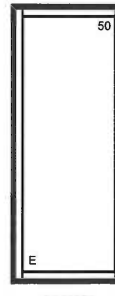

SCC3072  
SCPOC3072



SCC3272  
SCPOC3272

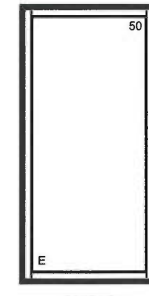

SCC3672  
SCPOC3672

**ELEVATION SYMBOL LEGEND:**

- M.O. = MASORNY OPENING
- VALUES IN ( ) ARE IN MILLIMETER CONVERSIONS
- E BASIC UNIT CLEAR OPENING EXCEEDS 20" IN WIDTH, 24" IN HEIGHT & A MINIMUM OF 5.7 SQ. FT., FOR SECOND FLOOR AND ABOVE EGRESS
- E1 BASIC UNIT CLEAR OPENING EXCEEDS 20" IN WIDTH, 24" IN HEIGHT & A MINIMUM OF 5.0 SQ. FT., FOR FIRST FLOOR EGRESS
- ## NUMBER INDICATES PERFORMANCE GRADE (PG) RATING WITH STANDARD GLAZING
- S STATIONARY UNITS ONLY

Note: Elevations shown DO NOT have exterior trim. Subtract 3/4"(19) from M.O.(Masonry Opening) for Unit Sizes. Masonry openings above include Sill Nose, see Trim Options page for Sill Nose specifications. For other Trim Options refer to the Unit Sizing, Rough Opening & Masonry Openings page.