

ADDENDUM No. 1

ITB No. 4597

Park Bridge Repairs and Renovations

Bids Due: October 25, 2019 at 10:00AM (Local Time)

The information contained herein shall take precedence over the original documents and all previous addenda (if any), and is appended thereto. **This Addendum includes twenty-five (25) pages.**

Bidder is to acknowledge receipt of this Addendum No. 1, including all attachments (if any) in its Bid by so indicating on page ITB-1 of the Invitation to Bid Form. Bids submitted without acknowledgment of receipt of this addendum may be considered nonconforming.

The following forms provided within the ITB document must be included in submitted bids:

- City of Ann Arbor Prevailing Wage Declaration of Compliance
- City of Ann Arbor Living Wage Ordinance Declaration of Compliance
- Vendor Conflict of Interest Disclosure Form
- City of Ann Arbor Non-Discrimination Ordinance Declaration of Compliance

Bids that fail to provide these forms listed above upon bid opening will be rejected as non-responsive and will not be considered for award.

I. CORRECTIONS/ADDITIONS/DELETIONS

Changes to the Bid document which are outlined below are referenced to a page or Section in which they appear conspicuously. The Bidder is to take note in its review of the documents and include these changes as they may affect work or details in other areas not specifically referenced here.

Section/Page(s)

Change

DS-1

As provided in ITB No. 4597 Bid Document:

Detailed Specification for Project Schedule, Page 1 of 2:

The Contractor shall begin the work of Phase 1 of this project on, or after, **Tuesday, December 4, 2019** and only upon receipt of the fully executed Contract and Notice to Proceed

As updated herein:

The Contractor shall begin the work of Phase 1 of this project on, or after, **Monday, January 6, 2020** and only upon receipt of the fully executed Contract and Notice to Proceed.

Comment: The intent with this change is to update the anticipated date for the notice to proceed.

DS-1 As provided in ITB No. 4597 Bid Document:
Detailed Specification for Project Schedule, Page 2 of 2:

City Council approval is expected **Monday, November 18, 2109**

As updated herein:

City Council approval is expected **Monday, December 2, 2109**

Comment: The intent with this change is to update the dates for anticipated contract approval by City Council.

DS-1 As provided in ITB No. 4597 Bid Document:
Detailed Specification for Guardrail, Type B, Modified, Page 1 of 1:

Payment for "Terminal End Shoe, Type B" (4 total) was added to the list of items included in payment for "Guardrail, Type B, Modified."

Comment: The intent with this change is to update the list of items included in this pay item.

Plans As updated herein:
The Title Sheet has been signed and sealed by the engineer.

Comment: The drawing set has been updated with the Engineer's signature and seal.

Plans Sheet 12 of 22 – *Bandemer Park Vehicle Structure Bridge Renovation Details* has been revised to include additional information related to Question 9 and Answer 9, below.

Comment: The drawing has been revised to indicate guardrail items that were only shown in the "Existing Structure Section" and indicated to be removed on Sheet 11 of 22 – Bandemer Park Vehicle Structure Existing Truss Conditions and Removal sheet.

II. QUESTIONS AND ANSWERS

The following Questions have been received by the City. Responses are being provided in accordance with the terms of the ITB. Bidders are directed to take note in their review of the documents of the following questions and City responses as they affect work or details in other areas not specifically referenced here.

Question 1: Will the pre-bid meeting sign-in sheet be provided?

Answer 1: See attached.

Question 2: Will the completion date be adjusted since the anticipated notice to proceed date has changed?

Answer 2: No changes will be made to the required completion date.

- Question 3: Will shop drawings be required for the Gallup Park structure or could we submit a specific product submittal instead?
Answer 3: Yes, shop drawings are required unless a product submittal is accepted in lieu.
- Question 4: If a structure is disassembled for field measurement, can it remain closed until work begins?
Answer 4: No, if any structure is disassembled for field measuring, it is required to be reassembled and opened for use until the actual construction begins.
- Question 5: Will additional tree clearing be permitted?
Answer 5: The contractor is able to request additional tree clearing to be conducted by Park Staff, and it will be evaluated on a case-by-case basis.
- Question 6: What is the access to the various structures?
Answer 6: Access to each structure varies and bidders are highly encouraged to visit the structure sites in person.
- Question 7: Are all of the bridge structures located on park property?
Answer 7: Yes, all bridge structures are located on park property, but the Mitchell Field structure abuts land owned by the University of Michigan on its western bank.
- Question 8: Are the vehicle lanes on the Gallup Park structure required to remain open during construction?
Answer 8: The vehicle lanes of the Gallup Park structure can be closed during working hours, but at least one pedestrian path must be open at all times, and the vehicle lanes must be open during non-work hours.
- Question 9: Is the Bandemer Park Vehicle structure guardrail to be replaced on all four quadrants of the approaches? Can you provide additional details for the work required on the approach railings? Are replacement approach terminals required?
Answer 9: Yes, the Bandemer Park Vehicle structure guardrail shall be replaced on all four quadrants of the approach, and on the structure itself. The short section of guardrail between the vehicle and adjacent pedestrian structure shall remain. The proposed guardrail endings on the approaches and the structure shall be Terminal End Shoe, Type B, which are included in the Pay Item "Guardrail, Type B, Modified."
- Question 10: Are there any restrictions on barges or equipment in the waterway to facilitate construction?
Answer 10: The City is not aware of any restrictions on barges or equipment in the waterway. However, we do require that a portion of the waterway remain open as stated in the specifications.
- Question 11: Have you submitted permit applications to the building department for review?
Answer 11: Permit applications have not been submitted to the building department but reviews are not anticipated to be long.
- Question 12: Can you provide an estimated cost for the required permits?
Answer 12: Estimated costs for building and soil erosion permits can be found on our website and are also attached.
- Question 13: Is there an engineer's cost estimate available?
Answer 13: There is not one available.

Question 14: Is there a plan holders list available?

Answer 14: There is a plan holders list available on MITN for those who have downloaded documents from MITN, but this does not include those who have downloaded documents directly from the City of Ann Arbor's website.

Question 15: Which wage determination shall apply to this contract?

Answer 15: Davis-Bacon Act WD # MI20190074, Modification #7, Construction Type Heavy, Last Revised Date: Sep 27, 2019. See attached wage determination.

Bidders are responsible for any conclusions that they may draw from the information contained in the Addendum.

CITY OF ANN ARBOR
DETAILED SPECIFICATION
FOR
PROJECT SCHEDULE

DLZ: MTL

Page 1 of 2

10/01/19

Examination of Plans, Specifications, and Work Site

The work of this project shall be completed while closing each structure to pedestrian and/or vehicle traffic (except for N. Barton Trail Pedestrian Structure, which shall remain open at all times, and except for one sidewalk on Gallup Park Vehicle Structure, which shall remain open at all times). See the Project Plans for additional information.

The Contractor is required to mobilize sufficient equipment and personnel, and work the necessary overtime, to complete the work within the timelines established herein. Bidders shall carefully examine the Bid Form, plans, specifications, and the work sites until the Bidder is satisfied as to all local conditions affecting the contract and the detailed requirements of construction. The submission of the bid shall be considered prima facie evidence that the Bidder has made such examinations and is satisfied as to the conditions to be encountered in performing the work and all requirements of the contract.

The entire work under this Contract shall be completed in accordance with, and subject to, the scheduling requirements as outlined below, and all other requirements of the Contract Documents.

1. This Project shall be conducted in two (2) phases, as outlined below. The Contractor shall begin the work of Phase 1 of this project on, or after, **Monday, January 6, 2020**, and only upon receipt of the fully executed Contract and Notice to Proceed.

Phase 1:

2. Phase 1 consists of work associated with substantial completion of the Gallup Park Vehicle Structure, the North Barton Pedestrian Structure and the South Barton Pedestrian Structure and shall be completed by **Friday, March 27, 2020**. Substantial completion of Phase 1 includes all structures that were closed to traffic being reopened to full public access and usage.

Phase 2:

3. Phase 2 shall commence upon substantial completion of Phase 1, and with written approval from the Engineer. Phase 2 consists of work associated with substantial completion of the Bandemer Park Pedestrian Structure, Bandemer Park Vehicle Structure, Argo Park Pedestrian Structure and Mitchell Field Pedestrian Structure, and shall be completed by **Monday, June 1, 2020**. Substantial completion includes all structures that were closed to traffic being reopened to full public access and usage.
4. The entire work under this contract shall be completed by **Monday, June 15, 2020**.

The Contractor shall submit a detailed schedule of work (progress schedule) for the Engineer's review and approval, two weeks prior to beginning work. The schedule shall clearly indicate, in detail, the start and the finish date of each work task on each structure. The Contractor shall update the approved progress schedule each week and present it to the Engineer at the weekly progress meeting and must consult with the Engineer for review and approval of any proposed

CITY OF ANN ARBOR
DETAILED SPECIFICATION
FOR
PROJECT SCHEDULE

DLZ: MTL

Page 2 of 2

10/01/19

deviations from the most current, approved, schedule.

The Contractor shall be furnished with two (2) copies of the Contract, for his/her execution, on or about **Monday, November 4, 2019.** The Contractor shall properly execute both copies of the Contract and return them, with the required Bonds and Insurance Certificate, to the City by **Wednesday, November 13, 2019.** The Contractor shall not begin the work before the applicable date(s) as described herein, and in no case before the receipt of the fully executed Contract. City Council approval is expected **Monday, December 2, 2019.**

The temporary closure (less than 1 day in length, with prior City approval) of a structure will be allowed, if necessary, for the Contractor to obtain field measurements. The Contractor shall immediately return the structure to the same, useable condition as it was before their work after any alterations/removal of components (decking, railing, etc.) are completed for these purposes

Failure to complete the work as specified, within the times specified, including time extensions granted thereto as determined by the Engineer, shall entitle the City to deduct from the payments due the Contractor \$900.00 in "Liquidated Damages", and not as a penalty, for each and every calendar day the work remains incomplete beyond the date specified. The length of time that each structure is closed to traffic shall be kept to the shortest duration possible so that disruptions to trail and park users are kept to a minimum. The Contractor shall not close a structure until all materials, equipment and labor is sufficient and available, in a continuous timeframe, to make constant progress and complete the work and reopen the structure as quickly as possible.

CITY OF ANN ARBOR
DETAILED SPECIFICATION
FOR
GUARDRAIL, TYPE B, MODIFIED

DLZ: MTL

Page 1 of 1

10/18/19

Description.

This work consists of providing all labor, materials, and equipment necessary to furnish and install the Type B Guardrail at the Bandemer Park Vehicle Structure and approaches, as indicated on the drawings and this Detailed Specification. Ensure all work is performed in accordance with this Detailed Specification, Section 807 of the Michigan Department of Transportation (MDOT) 2012 Standard Specifications for Construction, Local and State Building Codes, and the Americans with Disabilities Act.

Materials.

Provide all materials in accordance with Section 807 of the 2012 MDOT Standard Specifications for Construction. The guardrail sections (B rail and end shoes) and all hardware shall be hot-dip galvanized. The backup rails (HSS members) shall be weathering steel (ASTM A588). The guardrail backup HSS members shall be fabricated from high strength, low alloy, enhanced atmospheric corrosion resistant ASTM A847 cold-formed welded square or rectangular shape.

Construction.

Furnish and install all materials in accordance with the plans, this Detailed Specification and the MDOT Standard Specifications for Construction.

Measurement and Payment. The completed work, as described, will be measured and paid for at the contract unit price using the following pay item:

<u>Pay Item</u>	<u>Pay Unit</u>
Guardrail, Type B, Modified.....	Foot

Payment shall include fabrication, installation, all required hardware, Terminal End Shoes, Type B, and welding of B rail guardrail sections together. Payment for the HSS guardrail backup members shall be measured and paid for at the contract unit price for “**Structural Steel, Mixed, Erect**” and “**Structural Steel, Mixed, Furn and Fab**”.



BUILDING PERMIT FEES

CONSTRUCTION AND BUILDING

City Hall: 301 E. Huron St. Ann Arbor, MI 48104-6120

Mailing: P.O. Box 8647, Ann Arbor, MI 48107-8647

Building: 734.794.6263 ext. 0

building@a2gov.org

Fax: 734.994.8460

**Please provide payment information to process the application using the payment cover sheet.
Any application received without payment information included, cannot be processed.**

Activity

Effective July 1, 2017

Contractor Registration or Re-registration\$15

Base Application Fee for all permits (non-refundable with no inspections included)\$15

plus

Estimated Cost of Construction:

Up to \$1,000 (*includes one rough and one final inspection*) \$100*

\$1,000 – \$50,000 (*includes all inspections*).....\$100* + \$10 per \$1000 cost

\$50,000 – \$100,000 (*includes all inspections*)\$100* + \$9 per \$1000 cost

\$100,000+ (*includes all inspections*).....\$100* + \$8.50 per \$1000 cost

\$500,000+ (*includes all inspections*).....\$100* + \$8 per \$1000 cost

\$1,000,000+ (*includes all inspections*)\$100* + \$7.50 per \$1000 cost

plus

Plan Examination Fee (*Commercial or Residential*) 20% of building permit fee

Trades Plan Examination Fee25% of Building Plan Examination Fee

Please Note:

Revised plans submitted after initial review and approval for substantial changes to plans.....25% of original plan review fee, \$50 minimum

Each Inspection (*The Building Official reserves the right to charge for extra inspections*)..... \$35

Special or overtime inspection \$65/hour minimum 2 hours \$130 minimum

Historic District Staff Review (if located in an historic district).....\$35

Fences over 6 feet tall building permit fee



BUILDING PERMIT FEES

CONSTRUCTION AND BUILDING

City Hall: 301 E. Huron St. Ann Arbor, MI 48104-6120

Mailing: P.O. Box 8647, Ann Arbor, MI 48107-8647

Building: 734.794.6263 ext. 0

building@a2gov.org

Fax: 734.994.8460

Site Compliance Permit	\$150
Site Compliance Inspection	\$60
Certificate of Occupancy inspection	
Change of Occupancy (Commercial)	\$170
Change of Use	\$170
Temporary Certificate of Occupancy or renewal.....	\$30
Demolition:	
Accessory building	\$100* + \$10 per \$1,000 cost
House	\$100* + \$10 per \$1,000 cost
Commercial/Industrial, less than 10,000 square feet	\$100* + \$10 per \$1,000 cost
Commercial/Industrial, more than 10,000 square feet ..	\$100* + \$10 per \$1,000 cost
Basement Waterproofing	Same as Building Permit (requires <u>Grading Plan Review</u> and <u>Grading Permit</u> based on estimated cost of construction)
Above Ground Swimming Pool.....	\$125*
(*requires separate Plumbing and Electrical permits)	
Vacant Building Posting.....	\$100
Zoning Compliance permit	
For Building Projects up to \$10,000	\$20
For Building Projects over to \$10,000.....	\$50
Sheds under 200 square feet, includes one inspection	\$75
Permit Reactivation	\$35



BUILDING PERMIT FEES

CONSTRUCTION AND BUILDING

City Hall: 301 E. Huron St. Ann Arbor, MI 48104-6120

Mailing: P.O. Box 8647, Ann Arbor, MI 48107-8647

Building: 734.794.6263 ext. 0

building@a2gov.org

Fax: 734.994.8460

***Expiration of Permit:**

A permit remains valid as long as work is progressing and inspections are requested and conducted.

1. A permit shall become invalid if the authorized work is not commenced within 180 days after issuance of the permit or if the authorized work is suspended or abandoned for a period of 180 days after the time of commencing the work.
2. Any and all permits will be closed when no inspections are requested and conducted within 180 days of the date of issuance or the date of a previous inspection.
3. **Closed permits cannot be refunded. The charge to re-open a closed permit is \$35.00.**



City of Ann Arbor

PLANNING & DEVELOPMENT SERVICES — CONSTRUCTION SERVICES

Mailing: 301 E. Huron Street | P.O. Box 8647 | Ann Arbor, Michigan 48107-8647

Location: Larcom City Hall | First Floor | 301 E. Huron St. | Ann Arbor, MI 48104-6120

p. 734.794.6263 | f. 734.994.8460 | building@a2gov.org

GRADING/SOIL EROSION AND SEDIMENTATION CONTROL PERMIT FEES

Please provide payment information to process the application using the payment cover sheet.
Any application received without payment information included cannot be processed.

Activity	Effective July 1, 2017
Residential Grading Permit <i>(Includes plan review and up to four inspection)</i>	\$250
Residential Grading Permit – New Residence <i>(Includes plan review and up to four inspection)</i>	\$400
Additional Residential Inspection Fee.....	\$95
Non-Residential Grading Permit – Planning Petition Project <i>(Includes plan review, site evaluation, site compliance reviews)</i>	\$900
Grading Permit Revision to Approved Grading Plan (per hour)	\$85
Non-Residential Grading Permit <i>(Includes plan review and site evaluation)</i>	\$350
Non-Residential Grading Permit Monthly Inspection (per hour).....	\$95
Compliance Response Fee (Including Site Visit and Notice).....	\$500

Expiration of Permit: A permit remains valid as long as work is progressing and inspections are requested and conducted. A permit will be closed when no inspections are requested and conducted within 180 days of the date of issuance or the date of a previous inspection. Closed permits cannot be refunded. The charge to re-open a close permit is \$35.00.

"General Decision Number: MI20190074 09/27/2019

Superseded General Decision Number: MI20180074

State: Michigan

Construction Type: Heavy

County: Washtenaw County in Michigan.

Heavy, Includes Water, Sewer Lines and Excavation (Excludes Hazardous Waste Removal; Coal, Oil, Gas, Duct and other similar Pipeline Construction)

Note: Under Executive Order (EO) 13658, an hourly minimum wage of \$10.60 for calendar year 2019 applies to all contracts subject to the Davis-Bacon Act for which the contract is awarded (and any solicitation was issued) on or after January 1, 2015. If this contract is covered by the EO, the contractor must pay all workers in any classification listed on this wage determination at least \$10.60 per hour (or the applicable wage rate listed on this wage determination, if it is higher) for all hours spent performing on the contract in calendar year 2019. If this contract is covered by the EO and a classification considered necessary for performance of work on the contract does not appear on this wage determination, the contractor must pay workers in that classification at least the wage rate determined through the conformance process set forth in 29 CFR 5.5(a)(1)(ii) (or the EO minimum wage rate, if it is higher than the conformed wage rate). The EO minimum wage rate will be adjusted annually. Please note that this EO applies to the above-mentioned types of contracts entered into by the federal government that are subject to the Davis-Bacon Act itself, but it does not apply to contracts subject only to the Davis-Bacon Related Acts, including those set forth at 29 CFR 5.1(a)(2)-(60). Additional information on contractor

requirements and worker protections under the EO is available at www.dol.gov/whd/govcontracts.

Modification Number	Publication Date
0	01/04/2019
1	07/05/2019
2	07/19/2019
3	07/26/2019
4	08/09/2019
5	08/30/2019
6	09/20/2019
7	09/27/2019

CARP0687-006 06/01/2019

	Rates	Fringes
CARPENTER, Includes Form Work....	\$ 32.70	28.94

* ELEC0252-009 06/03/2019

	Rates	Fringes
ELECTRICIAN.....	\$ 45.78	24.33

ENGI0325-019 09/01/2018

POWER EQUIPMENT OPERATORS: Underground Construction (Including Sewer)

	Rates	Fringes
POWER EQUIPMENT OPERATOR		
GROUP 1.....	\$ 32.53	23.85
GROUP 2.....	\$ 27.80	23.85
GROUP 3.....	\$ 27.07	23.85
GROUP 4.....	\$ 26.50	23.85

POWER EQUIPMENT OPERATOR CLASSIFICATIONS

GROUP 1: Backhoe/ Excavator, Boring Machine, Bulldozer, Crane, Grader/ Blade, Loader, Roller, Scraper, Trencher (over 8 ft. digging capacity)

GROUP 2: Trencher (8-ft digging capacity and smaller)

GROUP 3: Boom Truck (non-swinging, non- powered type boom)

GROUP 4: Broom/ Sweeper, Fork Truck, Tractor, Bobcat/ Skid Steer /Skid Loader

ENGI0326-008 06/01/2019

EXCLUDES UNDERGROUND CONSTRUCTION

	Rates	Fringes
OPERATOR: Power Equipment		
GROUP 1.....	\$ 41.89	24.45
GROUP 2.....	\$ 40.39	24.45
GROUP 3.....	\$ 38.89	24.45
GROUP 4.....	\$ 38.59	24.45
GROUP 5.....	\$ 37.77	24.45
GROUP 6.....	\$ 36.91	24.45
GROUP 7.....	\$ 35.94	24.45
GROUP 8.....	\$ 34.23	24.45
GROUP 9.....	\$ 25.89	24.45

FOOTNOTES: Tower cranes: to be paid the crane operator rate determined by the combined length of the mast and the boom.

POWER EQUIPMENT OPERATOR CLASSIFICATIONS

GROUP 1: Crane with boom & jib or leads 400' or longer

GROUP 2: Crane with boom & jib or leads 300' or longer

GROUP 3: Crane with boom & jib or leads 220' or longer

GROUP 4: Crane with boom & jib or leads 140' or longer

GROUP 5: Crane with boom & jib or leads 120' or longer

GROUP 6: Regular crane operator

GROUP 7: Backhoe/Excavator, Bobcat/Skid Loader, Boring Machine, Broom/Sweeper, Bulldozer, Grader/Blade, Loader, Roller, Scraper, Tractor, Trencher

GROUP 8: Forklift

GROUP 9: Oiler

IRON0025-006 06/17/2018

	Rates	Fringes
IRONWORKER		
Reinforcing.....	\$ 29.48	27.74
Structural.....	\$ 35.52	28.65

LABO0334-009 06/01/2019

EXCLUDES OPEN CUT CONSTRUCTION

	Rates	Fringes
Landscape Laborer		
GROUP 1.....	\$ 20.75	7.10
GROUP 2.....	\$ 18.75	7.10

LANDSCAPE LABORER CLASSIFICATIONS

GROUP 1: Landscape specialist, including air, gas and diesel equipment operator, lawn sprinkler installer and skidsteer (or equivalent)

GROUP 2: Landscape laborer: small power tool operator, material mover, truck driver and lawn sprinkler installer

tender

LABO0334-018 09/01/2018

SCOPE OF WORK:

OPEN CUT CONSTRUCTION: Excavation of earth and sewer, utilities, and improvements, including underground piping/conduit (including inspection, cleaning, restoration, and relining)

	Rates	Fringes
LABORER		
(1) Common or General.....	\$ 23.75	12.85
(2) Mason Tender- Cement/Concrete.....	\$ 23.86	12.85
(4) Grade Checker.....	\$ 24.05	12.85
(5) Pipelayer.....	\$ 22.90	12.75
(524.20) Pipelayer.....	\$ 22.90	12.85
(7) Landscape.....	\$ 18.14	12.85

LABO0499-020 08/01/2019

EXCLUDES OPEN CUT CONSTRUCTION

	Rates	Fringes
LABORER		
GROUP 1.....	\$ 29.37	40.40
GROUP 2.....	\$ 29.58	40.40
GROUP 3.....	\$ 29.71	40.40

LABORER CLASSIFICATIONS

GROUP 1: Common or General; Grade Checker

GROUP 2: Mason Tender - Cement/Concrete

GROUP 3: Pipelayer

PAIN0022-005 07/01/2008

	Rates	Fringes
PAINTER		
Brush & Roller.....	\$ 25.06	14.75
Spray.....	\$ 25.86	14.75

PLAS0514-002 06/01/2018

	Rates	Fringes
CEMENT MASON/CONCRETE FINISHER...	\$ 31.47	13.81

PLUM0190-010 06/01/2019

	Rates	Fringes
PLUMBER.....	\$ 42.26	23.24

TEAM0007-006 06/01/2019

	Rates	Fringes
TRUCK DRIVER		
Dump Truck under 8 cu. yds.; Tractor Haul Truck....	\$ 27.15	.50 + a+b
Dump Truck, 8 cu. yds. and over.....	\$ 27.25	.50 + a+b
Lowboy/Semi-Trailer Truck...	\$ 27.40	.50 + a+b

FOOTNOTE:

- a. \$446.70 per week.
- b. \$67.00 daily.

SUMI2010-072 11/09/2010

Rates	Fringes
-------	---------

TRUCK DRIVER: Off the Road

Truck.....\$ 20.82 3.69

WELDERS - Receive rate prescribed for craft performing
operation to which welding is incidental.

=====

Note: Executive Order (EO) 13706, Establishing Paid Sick Leave
for Federal Contractors applies to all contracts subject to the
Davis-Bacon Act for which the contract is awarded (and any
solicitation was issued) on or after January 1, 2017. If this
contract is covered by the EO, the contractor must provide
employees with 1 hour of paid sick leave for every 30 hours
they work, up to 56 hours of paid sick leave each year.
Employees must be permitted to use paid sick leave for their
own illness, injury or other health-related needs, including
preventive care; to assist a family member (or person who is
like family to the employee) who is ill, injured, or has other
health-related needs, including preventive care; or for reasons
resulting from, or to assist a family member (or person who is
like family to the employee) who is a victim of, domestic
violence, sexual assault, or stalking. Additional information
on contractor requirements and worker protections under the EO
is available at www.dol.gov/whd/govcontracts.

Unlisted classifications needed for work not included within
the scope of the classifications listed may be added after
award only as provided in the labor standards contract clauses
(29CFR 5.5 (a) (1) (ii)).

The body of each wage determination lists the classification
and wage rates that have been found to be prevailing for the
cited type(s) of construction in the area covered by the wage
determination. The classifications are listed in alphabetical
order of ""identifiers"" that indicate whether the particular

rate is a union rate (current union negotiated rate for local), a survey rate (weighted average rate) or a union average rate (weighted union average rate).

Union Rate Identifiers

A four letter classification abbreviation identifier enclosed in dotted lines beginning with characters other than ""SU"" or ""UAVG"" denotes that the union classification and rate were prevailing for that classification in the survey. Example: PLUM0198-005 07/01/2014. PLUM is an abbreviation identifier of the union which prevailed in the survey for this classification, which in this example would be Plumbers. 0198 indicates the local union number or district council number where applicable, i.e., Plumbers Local 0198. The next number, 005 in the example, is an internal number used in processing the wage determination. 07/01/2014 is the effective date of the most current negotiated rate, which in this example is July 1, 2014.

Union prevailing wage rates are updated to reflect all rate changes in the collective bargaining agreement (CBA) governing this classification and rate.

Survey Rate Identifiers

Classifications listed under the ""SU"" identifier indicate that no one rate prevailed for this classification in the survey and the published rate is derived by computing a weighted average rate based on all the rates reported in the survey for that classification. As this weighted average rate includes all rates reported in the survey, it may include both union and non-union rates. Example: SULA2012-007 5/13/2014. SU indicates the rates are survey rates based on a weighted average calculation of rates and are not majority rates. LA indicates the State of Louisiana. 2012 is the year of survey on which these classifications and rates are based. The next number, 007 in the example, is an internal number used in producing the wage determination. 5/13/2014 indicates the survey completion date for the classifications and rates under that identifier.

Survey wage rates are not updated and remain in effect until a new survey is conducted.

Union Average Rate Identifiers

Classification(s) listed under the UAVG identifier indicate that no single majority rate prevailed for those classifications; however, 100% of the data reported for the classifications was union data. EXAMPLE: UAVG-OH-0010 08/29/2014. UAVG indicates that the rate is a weighted union average rate. OH indicates the state. The next number, 0010 in the example, is an internal number used in producing the wage determination. 08/29/2014 indicates the survey completion date for the classifications and rates under that identifier.

A UAVG rate will be updated once a year, usually in January of each year, to reflect a weighted average of the current negotiated/CBA rate of the union locals from which the rate is based.

WAGE DETERMINATION APPEALS PROCESS

1.) Has there been an initial decision in the matter? This can be:

- * an existing published wage determination
- * a survey underlying a wage determination
- * a Wage and Hour Division letter setting forth a position on a wage determination matter
- * a conformance (additional classification and rate) ruling

On survey related matters, initial contact, including requests for summaries of surveys, should be with the Wage and Hour Regional Office for the area in which the survey was conducted because those Regional Offices have responsibility for the Davis-Bacon survey program. If the response from this initial contact is not satisfactory, then the process described in 2.)

and 3.) should be followed.

With regard to any other matter not yet ripe for the formal process described here, initial contact should be with the Branch of Construction Wage Determinations. Write to:

Branch of Construction Wage Determinations
Wage and Hour Division
U.S. Department of Labor
200 Constitution Avenue, N.W.
Washington, DC 20210

2.) If the answer to the question in 1.) is yes, then an interested party (those affected by the action) can request review and reconsideration from the Wage and Hour Administrator (See 29 CFR Part 1.8 and 29 CFR Part 7). Write to:

Wage and Hour Administrator
U.S. Department of Labor
200 Constitution Avenue, N.W.
Washington, DC 20210

The request should be accompanied by a full statement of the interested party's position and by any information (wage payment data, project description, area practice material, etc.) that the requestor considers relevant to the issue.

3.) If the decision of the Administrator is not favorable, an interested party may appeal directly to the Administrative Review Board (formerly the Wage Appeals Board). Write to:

Administrative Review Board
U.S. Department of Labor
200 Constitution Avenue, N.W.
Washington, DC 20210

4.) All decisions by the Administrative Review Board are final.

=====

END OF GENERAL DECISION"

THE CITY OF ANN ARBOR

PARKS & RECREATION SERVICES 2019 PARK BRIDGE REPAIRS AND RENOVATIONS OCTOBER 2019 ITB NO. 4597

NOTES:

THE PROPOSED IMPROVEMENTS ARE BASED ON THE 17TH EDITION OF AASHTO STANDARD SPECIFICATIONS FOR HIGHWAY BRIDGES.

EXCEPT WHERE OTHERWISE INDICATED ON THESE PLANS OR IN THE CONTRACT DOCUMENTS, ALL MATERIALS AND WORKMANSHIP SHALL BE PERFORMED ACCORDING TO THE CITY OF ANN ARBOR'S PUBLIC SERVICES DEPARTMENT STANDARD SPECIFICATIONS AND THE MICHIGAN DEPARTMENT OF TRANSPORTATION STANDARD SPECIFICATIONS FOR CONSTRUCTION 2012 EDITION. ALL WORK UNDER THIS CONTRACT THAT IS NOT INCLUDED IN THE CITY OR MDT STANDARD SPECIFICATIONS SHALL BE PERFORMED IN ACCORDANCE WITH THE DETAILED SPECIFICATIONS INCLUDED IN THE CONTRACT DOCUMENTS.

IN CASE OF DISCREPANCY, THE CITY OF ANN ARBOR PUBLIC SERVICES DEPARTMENT STANDARD SPECIFICATIONS FOR CONSTRUCTION SHALL GOVERN OVER THE MICHIGAN DEPARTMENT OF TRANSPORTATION STANDARD SPECIFICATIONS FOR CONSTRUCTION.

THE DESIGN OF THE STRUCTURAL MEMBERS IS BASED ON MATERIAL OF THE FOLLOWING GRADES AND STRESSES:

CONCRETE: GRADE S2	$f_c = 3,000$ psi
CONCRETE: GRADE D	$f_c = 4,000$ psi
STEEL REINFORCEMENT	$f_y = 60,000$ psi
STRUCTURAL STEEL:	
AASHTO M270	
GRADE 36	$F_y = 36,000$ psi
GRADE 50 AND 50W	$F_y = 50,000$ psi
STRUCTURAL STEEL TUBING (HSS):	
ASTM A847	$F_y = 50,000$ psi

ALL EXPOSED CONCRETE CORNERS SHOWN SQUARE ON THE PLANS SHALL BE BEVELED WITH $\frac{3}{8}$ " TRIANGULAR MOLDINGS EXCEPT AS OTHERWISE NOTED.

UNLESS OTHERWISE SHOWN ON THE PLANS PROVIDE MINIMUM CONCRETE CLEAR COVER FOR REINFORCEMENT ACCORDING TO THE FOLLOWING:

CONCRETE CAST AGAINST EARTH:	3 IN.
ALL OTHER UNLESS SHOWN ON PLANS:	2 IN.

PERMITS REQUIRED TO BE OBTAINED BY THE CONTRACTOR PRIOR TO THE BEGINNING OF CONSTRUCTION. CONTRACTOR IS RESPONSIBLE FOR THESE PERMIT FEES.	
PERMIT	ISSUING AUTHORITY
GRADING/ SOIL EROSION & SEDIMENTATION CONTROL PERMIT	CITY OF ANN ARBOR PLANNING AND DEVELOPMENT SERVICES UNIT
BUILDING PERMIT	CITY OF ANN ARBOR PLANNING AND DEVELOPMENT SERVICES UNIT
RIGHT-OF-WAY PERMIT	CITY OF ANN ARBOR PLANNING AND DEVELOPMENT SERVICES UNIT

SHEET INDEX

SHEET NO.	DESCRIPTION
1	COVER SHEET
2	NOTE AND QUANTITY SHEET
3-4	NORTH BARTON PEDESTRIAN STRUCTURE
5-7	SOUTH BARTON PEDESTRIAN STRUCTURE
8-12	BANDEMER PARK PEDESTRIAN AND VEHICLE STRUCTURES
13-14	ARGO PARK PEDESTRIAN STRUCTURE
15-19	MITCHELL FIELD PEDESTRIAN STRUCTURES
20-22	GALLUP PARK VEHICLE STRUCTURE

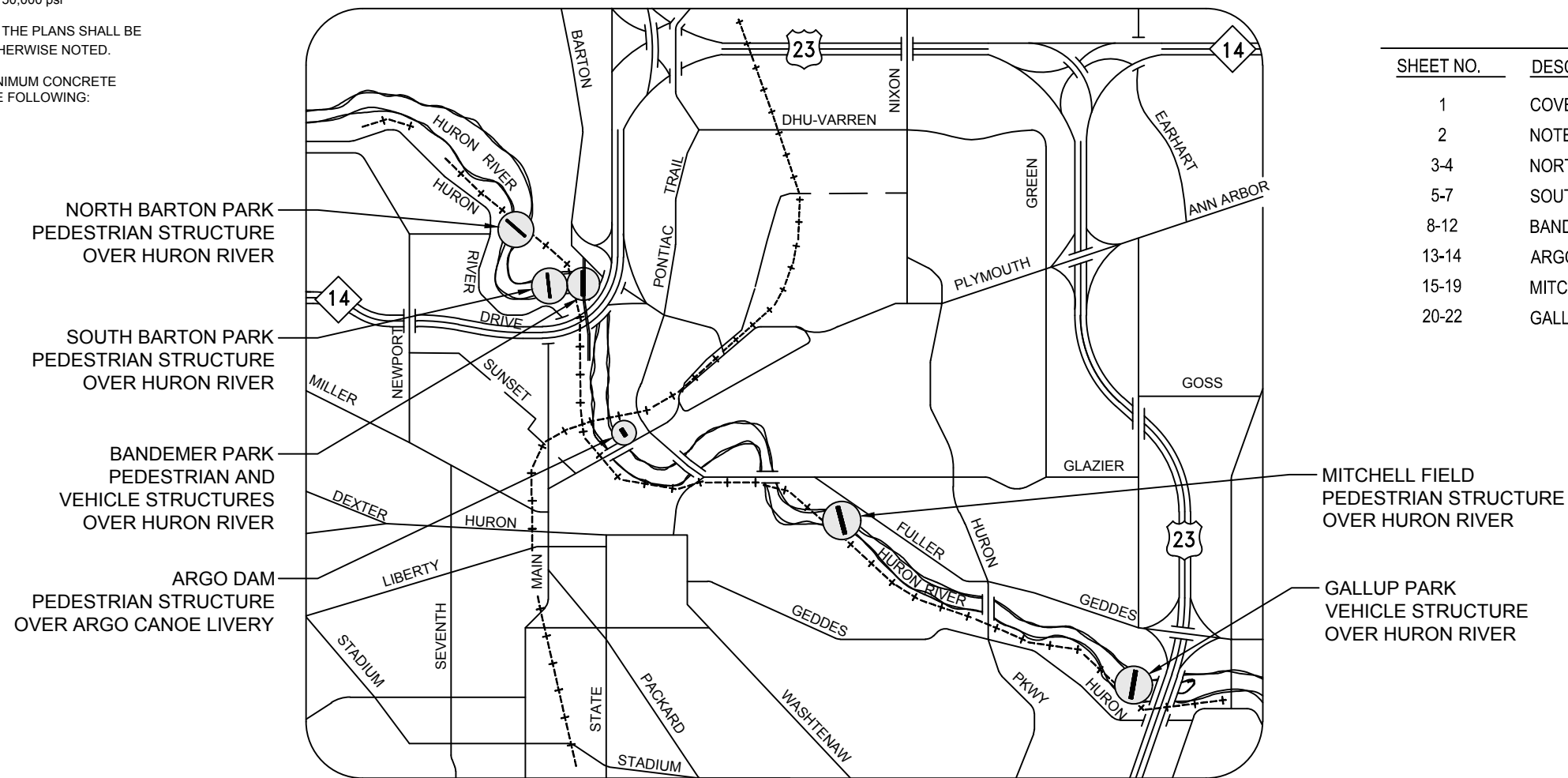

3 WORKING DAYS |
BEFORE YOU DIG
CALL MISS DIG
800-482-7171
(TOLL FREE)

FOR PROTECTION OF UNDERGROUND UTILITIES AND IN CONFORMANCE WITH PUBLIC ACT 53, THE CONTRACTOR SHALL DIAL 1-800-482-7171 A MINIMUM OF THREE FULL WORKING DAYS, EXCLUDING SATURDAYS, SUNDAYS, AND HOLIDAYS PRIOR TO BEGINNING EACH EXCAVATION IN AREAS WHERE PUBLIC UTILITIES HAVE NOT BEEN PREVIOUSLY LOCATED. MEMBERS WILL BE ROUTINELY NOTIFIED. THIS DOES NOT RELIEVE THE CONTRACTOR OF THE RESPONSIBILITY OF NOTIFYING UTILITY OWNERS WHO MAY NOT BE A PART OF THE "MISS DIG" ALERT SYSTEM.

THE OMISSION OF ANY CURRENT STANDARD DETAIL DOES NOT RELIEVE THE CONTRACTOR FROM THIS REQUIREMENT. THE WORK SHALL BE PERFORMED IN COMPLETE CONFORMANCE WITH THE CURRENT PUBLIC SERVICES STANDARD SPECIFICATIONS AND DETAILS.



MARK T. LESSENS, P.E., MICHIGAN NO. 36092



DATE

DRAWING NO.

SHEET 1 OF 22

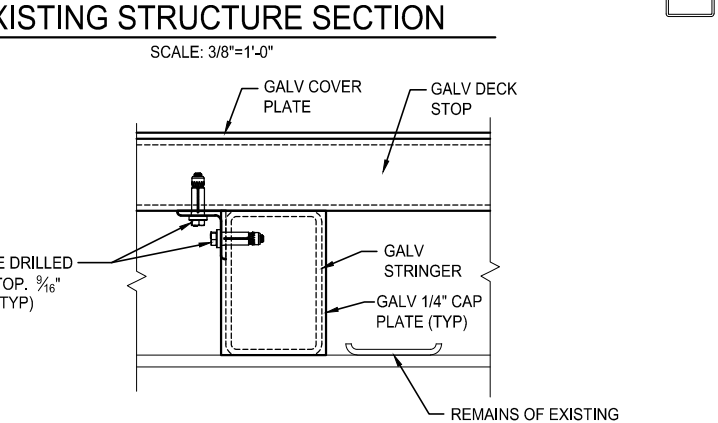
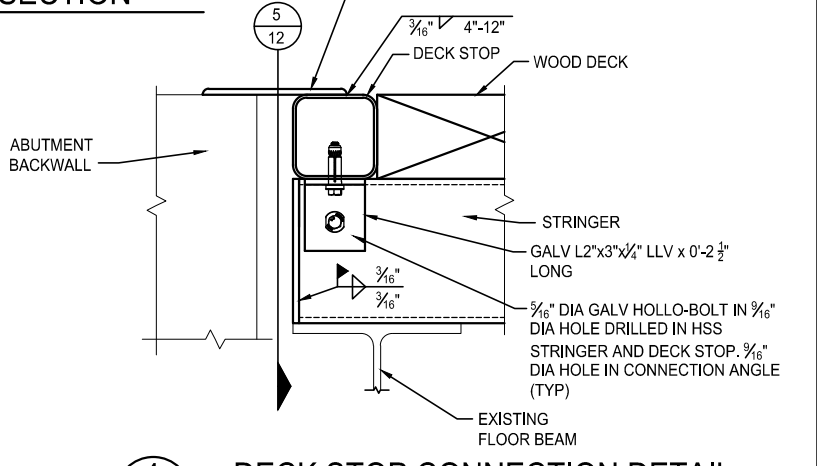
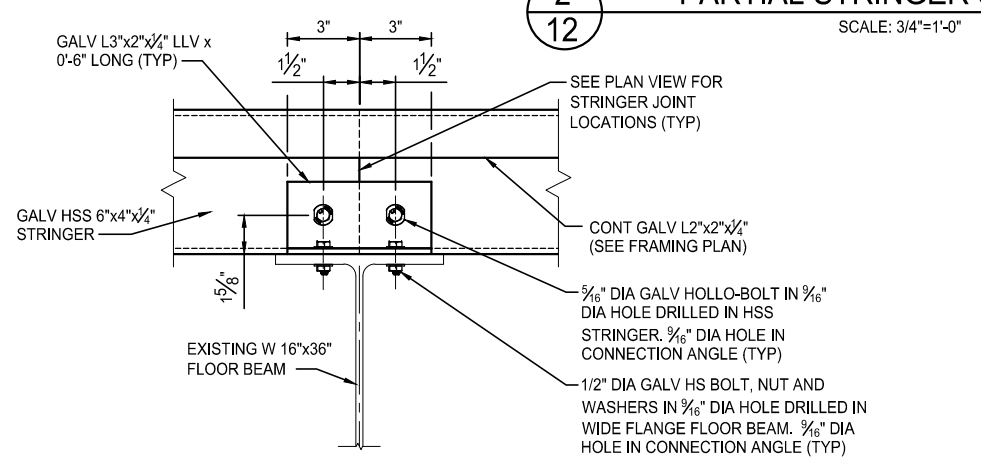
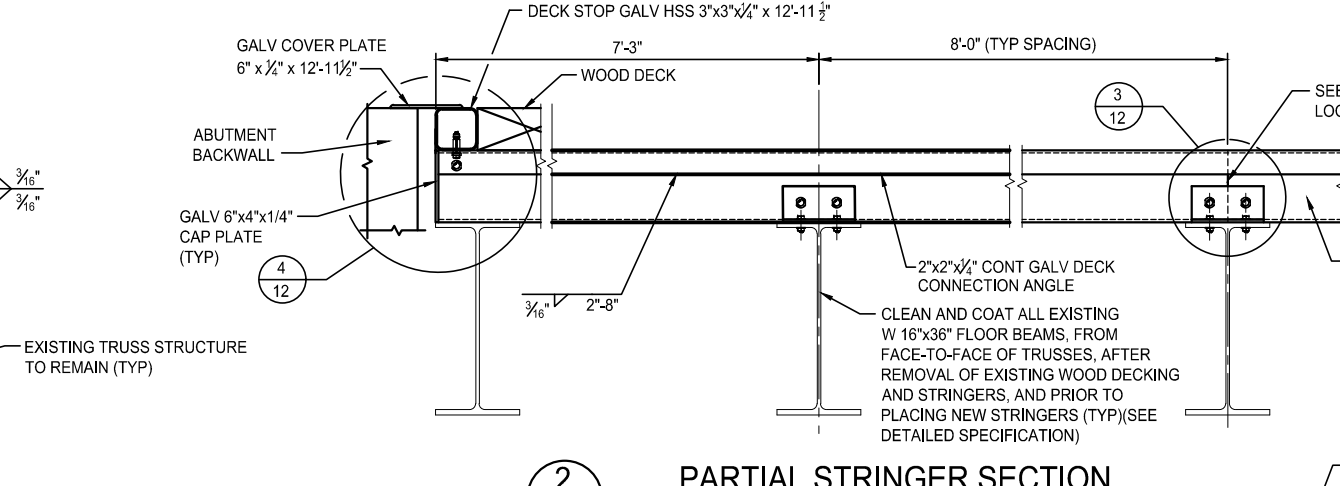
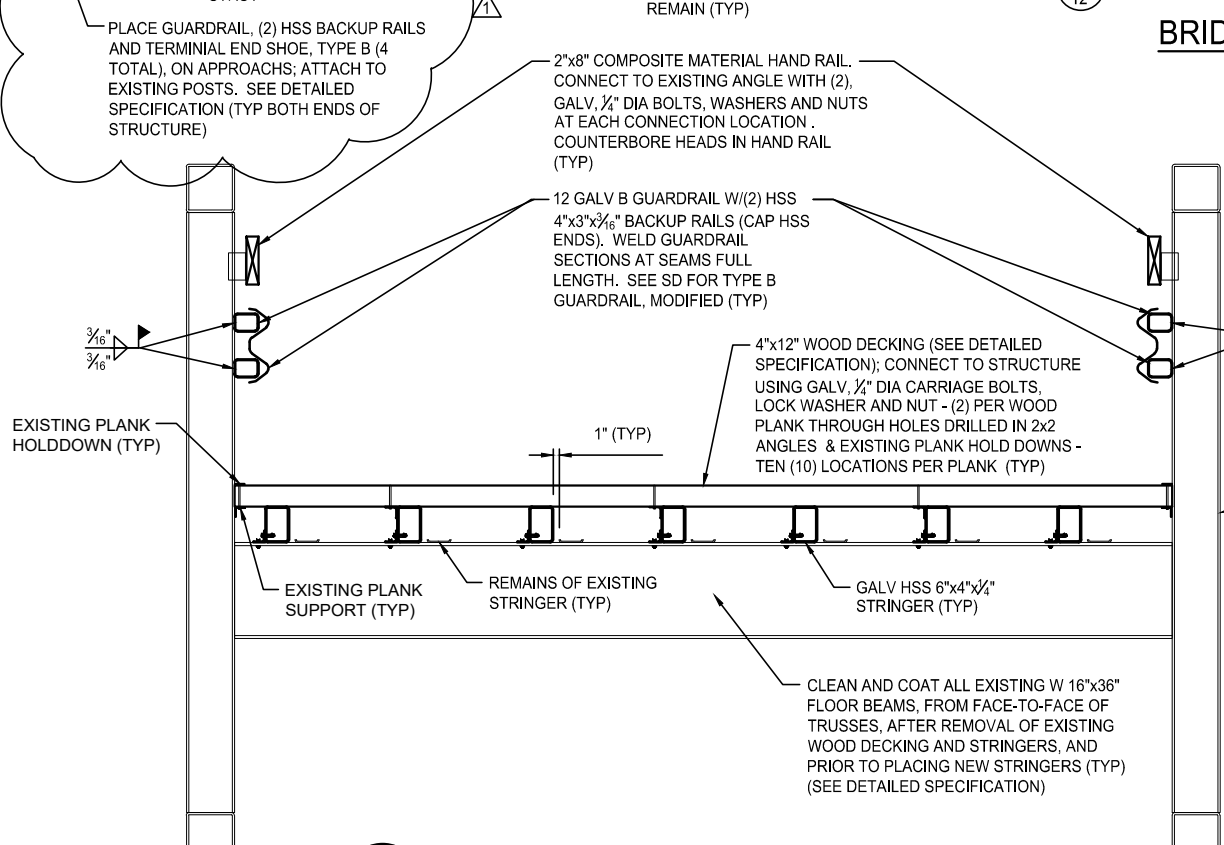
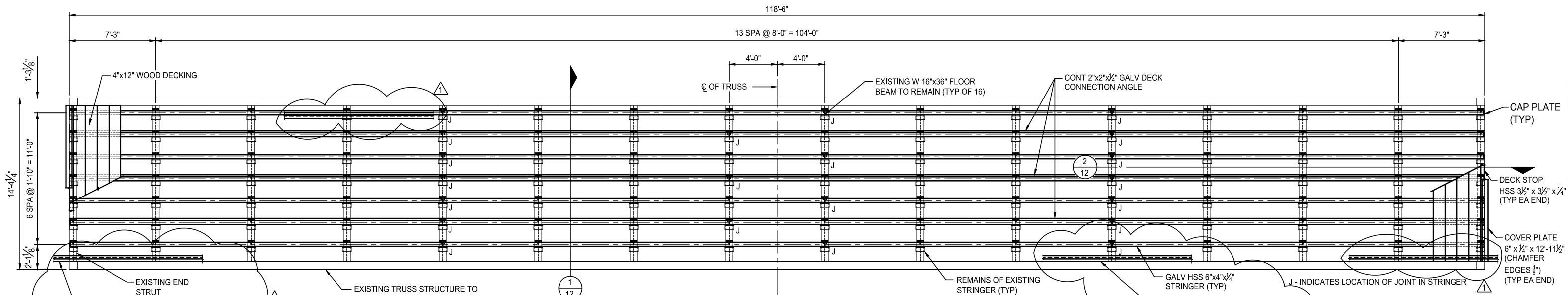

DLZ				
1	ADDENDUM	10/18/19	DAF	CLH
	ORIGINAL ISSUE	10/01/19	DAF	CLH
REV. NO.	DESCRIPTION	DATE	DR. BY	CH. BY

THE CITY OF ANN ARBOR - PARKS AND RECREATION SERVICES

2019 PARK BRIDGE REPAIRS AND RENOVATIONS

BANDEMOR PARK VEHICLE STRUCTURE BRIDGE RENOVATION DETAILS

SCALE	AS SHOWN
DRAWING NO.	
SHEET NO.	12 OF 22