

## **PLANNING AND DEVELOPMENT SERVICES STAFF REPORT**

**For Planning Commission Meeting of November 19, 2013**

**SUBJECT: Briarwood Restaurants Site Plan for City Council Approval  
700 Briarwood Circle  
File No. SP13-036**

### **PROPOSED CITY PLANNING COMMISSION MOTION**

The Ann Arbor City Planning Commission hereby recommends that the Mayor and City Council approve the Briarwood Restaurants Site Plan and Development Agreement, subject to approval by the Washtenaw County Water Resources Commissioner prior to City Council action on the site plan.

### **STAFF RECOMMENDATION**

Staff recommends that this petition be **approved**, because if the proposed conditions are met, the development would comply with local, state and federal laws and regulations; would not cause a public or private nuisance; and would not have a detrimental effect on public health, safety or welfare. The site contains no natural features.

### **STAFF REPORT**

The Briarwood Restaurants rezoning and site plan petitions were postponed by the Planning Commission at the October 15th, 2013 meeting to allow for plan revisions that address issues noted by the City's System Planning, Natural Resources, Solid Waste and Planning staff. After completing the review of revised plans, City staff has confirmed that all outstanding issues have been addressed.

In addition, Planning staff research has verified that the original 1973 Briarwood Mall zoning anticipated Hudson's (now Macy's) expansion to the east. As a result of this research, staff has concluded that the proposed development area is currently zoned C2B and will not need to be rezoned. Staff has closed the rezoning file, and the petition has been revised to request approval of the site plan only.

A development agreement has been drafted to address utility construction, easements and modifications to the regional storm water detention facilities.

### **UNIT COMMENTS**

Fire Marshal – Two new fire department connections have been added to the revised site plans to comply with the Code for fire hydrants within 250 feet of the new development and the Macy's parcel.

Systems Planning – Engineering –The petitioner provided survey documents displaying the ownership of mall parcels and access roads. Simon owns Parcel II and the attached private access road, Mall Drive, that provides access to the site. The utility easement required for water and sewer will be revised by the petitioner to provide the necessary setbacks from the proposed development.

Systems Planning – Natural Resources – The petitioner has revised the plan to comply with requirements for the landscape islands. In addition, revisions were made to display how the storm water would enter the bio-swales and retain water run-off.

Systems Planning - Solid Waste – The previous site plan displayed a refuse and service area for Restaurant B that did not meet the required 20 foot width per the code. Concerns were raised at the Planning Commission meeting regarding the potential conflicts between trucks backing into this service area and vehicular and pedestrian traffic from the adjacent tenants. The revised site plan shows reconfigured solid waste facilities, including two 10 x 14 foot compactors, one wet and one recycler, within the proposed service area. Solid Waste staff reviewed and approved the revised plans.

Washtenaw County Water Resources Commissioner – At the recommendation of Washtenaw County Water Resources Commissioner and Systems Planning staff, the petitioner removed the detention pond proposed at the northeast corner of the Simon site. Storm water requirements will instead be met by the retrofitting and dredging of the existing detention pond north of the proposed site.

The proposed modifications were determined to be beneficial because the existing pond Number 5 has not been operating properly for some time. The WCWRC felt the best solution would be to redesign and dredge the existing pond instead of constructing a new pond. Mitigating the storm water run-off through the regional system would be best since it has the capacity and would serve multiple projects. The improvement to the existing retention pond would benefit multiple parcels instead of just one. Additional landscape islands were included on both the Macy's and Simon parcels to help mitigate storm water run-off.

Planning – Staff researched the history of the parcel splits for Briarwood Mall and determined the parcel boundaries put into place shortly after construction of the mall were not reviewed for compliance with zoning requirements. The Simon property as currently configured has frontage on East Eisenhower Parkway and South State Street, although the frontages in both locations are actually private drives. The Macy's parcel frontage on East Eisenhower is the width of Plaza Drive. As such, the strict application of maximum front setback requirements for new free-standing buildings would be illogical in this situation. For the reconfigured Simon parcel, staff has interpreted that the property line just east of the proposed restaurants will be identified as the "front" for purposes of the maximum setback requirement. Restaurant A will be located 12.7 feet from the property line; Restaurant B will be located 20.3 feet from the property line.

The existing parking lot for the Macy's site contains 1,237 spaces, and the Simon parcel contains 223 spaces. Since the mall was developed prior to maximum parking requirements, the parking for both parcels is considered to be non-conforming because it exceeds the maximum. As a non-conforming situation, the parking count may continue with this number or be reduced,

but it is not required to be brought into conformance at this time. The site plan proposes the reduction of 173 spaces on the Macy site and 15 spaces on the Simon site.

Bicycle parking will be added to the Macy's site on the Northern entrance and the western entrance. The petitioner will provide a total of 40 Class B and Class C, and the additional 26 required spaces will be deferred. The Simon parcel site will contain six Class B and six Class C bicycle parking spaces, with 6 being deferred.

The revised comparison charts are provided below.

**REVISED COMPARISON CHART – MACY'S PARCEL**

	<b>EXISTING</b>	<b>PROPOSED</b>	<b>REQUIRED</b>
Zoning	P (Parking) & C2B (Business Service)	P (Parking) & C2B (Business Service)	P (Parking) & C2B (Business Service)
Gross Lot Area	821,040 sf (18.87 acres)	775,520 sf (17.80 acres)	(P) None (C2B) 4,000 sf MIN
Floor Area in Percentage of Lot Area	23% (189,054 sf)	24% (189,054 sf)	(P) None (C2B) 200% MAX
Front Setback (North)	516 ft	516 ft	(P) 10 ft (C2B) 10 ft MIN, 25 ft MAX
Height	35 ft	35 ft	(P) N/A (C2B) 55 ft MAX
Parking - Automobiles	1,237 spaces	1,064 spaces*	731 spaces MIN 825 spaces MAX
Parking – Bicycles	0	20 Class B 20 Class C 26 Deferred	33 Class B MIN 33 Class C MIN

\* Non-conformity reduced as a result of proposed changes.

**REVISED COMPARISON CHART -SIMON PARCEL**

	<b>EXISTING</b>	<b>PROPOSED</b>	<b>REQUIRED</b>
Zoning	P (Parking) C2B (Business Service)	P (Parking) C2B (Business Service)	P (Parking) C2B (Business Service)
Gross Lot Area	144,575 sf (3.3 acres)	191,096 sf (4.4 acres)	(P) None (C2B) 4,000 sf MIN
Floor Area in Percentage of Lot Area	N/A	9% (15,714 sf)	(P)None (C2B)200% MAX
Front Setback (East)	N/A	12.7 ft (Restaurant A) 20.3 ft (Restaurant B)	(P) 10 ft (C2B) 10ft MIN, 25ft MAX
Height	N/A	25 ft	(P) N/A (C2B) 55 ft MAX
Parking - Automobiles	223 spaces	208 spaces*	59 spaces MIN 67 spaces MAX
Parking – Bicycles	0	6 Class B 6 Class C 6 Deferred	9 Class B MIN 9 Class C MIN

\* Non-conformity reduced as a result of proposed changes.

Prepared by: Angeline Lawrence  
 Reviewed by: Wendy Rampson  
 11/14/13

Attachment: 10/15/13 Planning Staff Report  
 11/14/13 Draft Development Agreement  
 11/06/13 Land Survey  
 11/06/13 Revised Macy's Site Plan  
 11/06/13 Revised Simon's Site Plan

c: City Attorney's Office  
 Systems Planning

**PLANNING AND DEVELOPMENT SERVICES STAFF REPORT**

**For Planning Commission Meeting of October 15, 2013**

**SUBJECT: Briarwood Restaurants Rezoning and Site Plan for City Council Approval  
700 Briarwood Circle  
File No. SP13-036**

**PROPOSED CITY PLANNING COMMISSION MOTION**

The Ann Arbor City Planning Commission hereby recommends that the Mayor and City Council approve the Briarwood Restaurants rezoning from P (Parking District) to C2B (Business Service District).

**PROPOSED CITY PLANNING COMMISSION MOTION**

The Ann Arbor City Planning Commission hereby recommends that the Mayor and City Council approve the Briarwood Restaurants Site Plan, subject to approval of the plan by the Washtenaw County Water Resources Commissioner prior to City Council action on the site plan.

**STAFF RECOMMENDATION**

Staff recommends that this petition be **postponed** to allow the petitioner to address comments regarding zoning, landscaping, easements and utility comments.

**LOCATION**

The site is located on the south side of Briarwood Circle Drive, west of S. State Street. This site is located in the Malletts Creek Watershed.

**DESCRIPTION OF PETITION**

The petitioner, Simon Company, proposes to construct two single-story restaurants just east of the existing Macy's Department store. The northern building, Restaurant "A", would be 6,470 square feet with a 920 square foot covered patio area; and the southern building, Restaurant "B", would be 7,068 square feet with a 1,256 square foot open patio area. Landscaping and a pedestrian plaza with benches would be provided as a connector between the two restaurants.

To create the development site, the Macy's lot line would be shifted west of the proposed restaurants, with the restaurants being located on the extension of an adjacent parcel owned by the Simon Company that currently contains surface parking. This proposal includes rezoning a portion of the parking lot from P to C2B where the restaurants would be located.

The parking lot on the expanded Simon Company parcel east of the new restaurants would be reconfigured to provide 115 parking spaces, including 4 barrier free spaces, a reduction of 108 spaces. Bicycle parking for the restaurants will be provided in the area between the two restaurants: 10 Class B bicycle parking spaces and 8 Class C bicycle parking spaces.

The Macy's parking lot would be reconfigured to include new landscaping and bio-swale islands. These modifications, along with the lot line shift, would result in 1,058 parking spaces, including 21 barrier free spaces, being provided, resulting in a loss of 179 parking spaces.

A landscaped island with a pedestrian path located perpendicular to Briarwood Circle and south of Plaza Drive would be provided to connect to the existing mall sidewalk just east of the restaurants. Two crosswalks at the northeast and southeast sides of the restaurants would be provided through the Macy's parking lot.

The proposed development would drain into the existing regional storm water system. A sedimentation basin is proposed at the north end of the Simon Company parcel to filter storm water runoff. There are no natural features on either parcels.

The project will be phased to provide ingress and egress to all existing entrances. Estimated construction cost is \$ 1,577,094.

### **CITIZEN PARTICIPATION**

As required by the Citizen Participation Ordinance, the petitioner mailed out postcard notifications. A citizen participation meeting was held on Thursday, August 15, 2013 on the Briarwood Mall site. Many of the mall tenants attended the meeting. Their concerns included operation of shipping docks located near the proposed restaurants, access to the ring road during construction and compliance to the Americans with Disabilities Act (ADA) standards for patrons with disabilities. To date, staff has not received any other comments or concerns from the public.

### **SURROUNDING LAND USES AND ZONING**

	LAND USE	ZONING
NORTH	Office	O (Office)
EAST	Parking, Office	PUD (Planned Unit Development) P (Parking)
SOUTH	Retail	C2B (Business Service)
WEST	Public Land & Residential	P (Parking)

**COMPARISON CHART –SIMON COMPANY PARCEL**

		EXISTING	PROPOSED	REQUIRED
Zoning		P (Parking) & C2B (Business Service)	C2B (Business Service)	C2B
Gross Lot Area		80,150 sq. ft. (1.84 acres)	126,760 sq.ft. (2.91 acres)	4,000 sf MIN
Floor Area in Percentage of Lot Area		N/A	12% (15,714 sq.ft.)	200% MAX (253,520 sq. ft.)
Setbacks	Front (East)	Under Review	Under Review	10ft MIN 25ft MAX
	Side (South)	Under Review	Under Review	None
	Rear (West)	Under Review	Under Review	None
Height		N/A	25 ft.	55 ft. MAX
Parking - Automobiles		223 spaces	115 spaces	59 spaces MIN 67 spaces MAX
Parking – Bicycles		0	10 Class B spaces 8 Class C spaces	3 Class B MIN 3 Class C MIN

**COMPARISON CHART – MACY’S PARCEL**

		EXISTING	PROPOSED	REQUIRED
Zoning		P (Parking) & C2B (Business Service)	P & C2B	P & C2B
Gross Lot Area		821,977 (18.87 acres)	775,368 sq.ft. (17.80 acres)	None (P) 4,000 sq.ft. MIN (C2B)
Floor Area in Percentage of Lot Area		23% (189,054 sq.ft.)	41% (189,054 sq.ft.)	200% MAX (C2B) (1,550,736 sq. ft.)
Setbacks	Front (East)	Under Review	Under Review	10 ft (P) 10 ft MIN 25 ft MAX (C2B)
	Side (South)	Under Review	Under Review	2.5 ft (P) None (C2B)
	Rear (West)	Under Review	Under Review	2.5 ft (P) None (C2B)
Height		None	None	55 ft. MAX (C2B)
Parking - Automobiles		1,237 spaces	1,058 spaces	731 MIN 825 MAX
Parking – Bicycles		0	Under Review	33 Class B MIN 33 Class B MIN

## HISTORY

Briarwood Shopping Mall was completed in 1973. When the mall was developed, the property was divided into X parcels, each with associated parking. The mall building was zoned C2B; the parking lots were zoned P. Several administrative amendments were completed to the Mall to allow for new retail stores, such as J.C. Penney's in 1972, Lord and Taylor in 1980, Jacobson's in 1993. In 1987, an administrative amendment was approved to allow for a 4,500-square foot storage mezzanine on the first floor of the former Hudson's Department Store.

## PLANNING BACKGROUND

The recently adopted South State Street Corridor amendments to the City of Ann Arbor Master Plan: Land Use Element provide area-specific recommendations for Area 2, which includes Briarwood Mall/ The plan recommends working with Briarwood Mall to develop a safe designated pedestrian pathway from crosswalks to mall entrances through the parking lot. The plan also recommends evaluating innovative parking solutions to utilize land more efficiently.

Site-specific recommendations for the Briarwood Mall (site 2A) support rezoning of the P districts to C2B in coordination with redevelopment of the mall to increase its FAR.

## UNIT COMMENTS

Fire - The entire footprint for Macy's does not meet the 250 foot hydrant radius requirement. The site plan shows two hydrants, one on the northwest and the other on the northeast of Macy's. However, the Fire Marshall has indicated that they are Post Indicator Values (PIV's) and not hydrants; they cannot be used to meet hydrant radius requirements. The proposed FDC for proposed restaurant A does not meet the minimum 100 foot distance from a supporting hydrant.

Systems Planning – Engineering - A permanent 30-foot wide, unobstructed easement for access and utilities must be provided for the parcels not fronting on a public street or right-of-way according to City Code Chapter 55, Section 5:77. The site plans did not provide a location for the easement.

The footing drains for the existing building must be disconnected from the sanitary sewer system if they are currently connected. Footing drains removed from any existing buildings may offset required mitigation for the restaurant site.

Systems Planning – Natural Resources - Per Chapter 62 5:602(2)(d), a maximum of 15 parking spaces are allowed in a row without a landscape island break. A maximum of 20 continuous spaces will be permitted if larger landscape islands have been combined and are used for bio-retention. The parking lot has several rows that exceed 15 parking spaces in the row and the combined island requirement has not been met.

Systems Planning - Solid Waste - The dumpster areas for these restaurants need to be widened to 20 feet clear opening to allow space for a second dumpster for recycling.



Washtenaw County Water Resources Commission – Staff has not received the final approval from the WCWRC. The site is located in the Mallets Creek Watershed and is part of a regional detention system and therefore must be approved by the WCWRC before going to the City Council for approval.

Planning – Outstanding issues are the extent of the requested rezoning; receipt of an authorization letter from Macy's; location of bicycle parking on the Macy's site; and bicycle parking details.

Prepared by: Angeline Lawrence  
Reviewed by: Wendy Rampson

Attachments: Zoning/Parcel Map  
Aerial Photo  
Site Plan  
Elevations  
Citizen Participation Report





c: Petitioner/Owner: Simon Company  
225 W. Washington St.  
Indianapolis, IN 46204

Petitioner's Representative: Hubbell, Roth & Clark, Inc.  
555 Hulet Dr.  
Bloomfield Hills, MI 48303

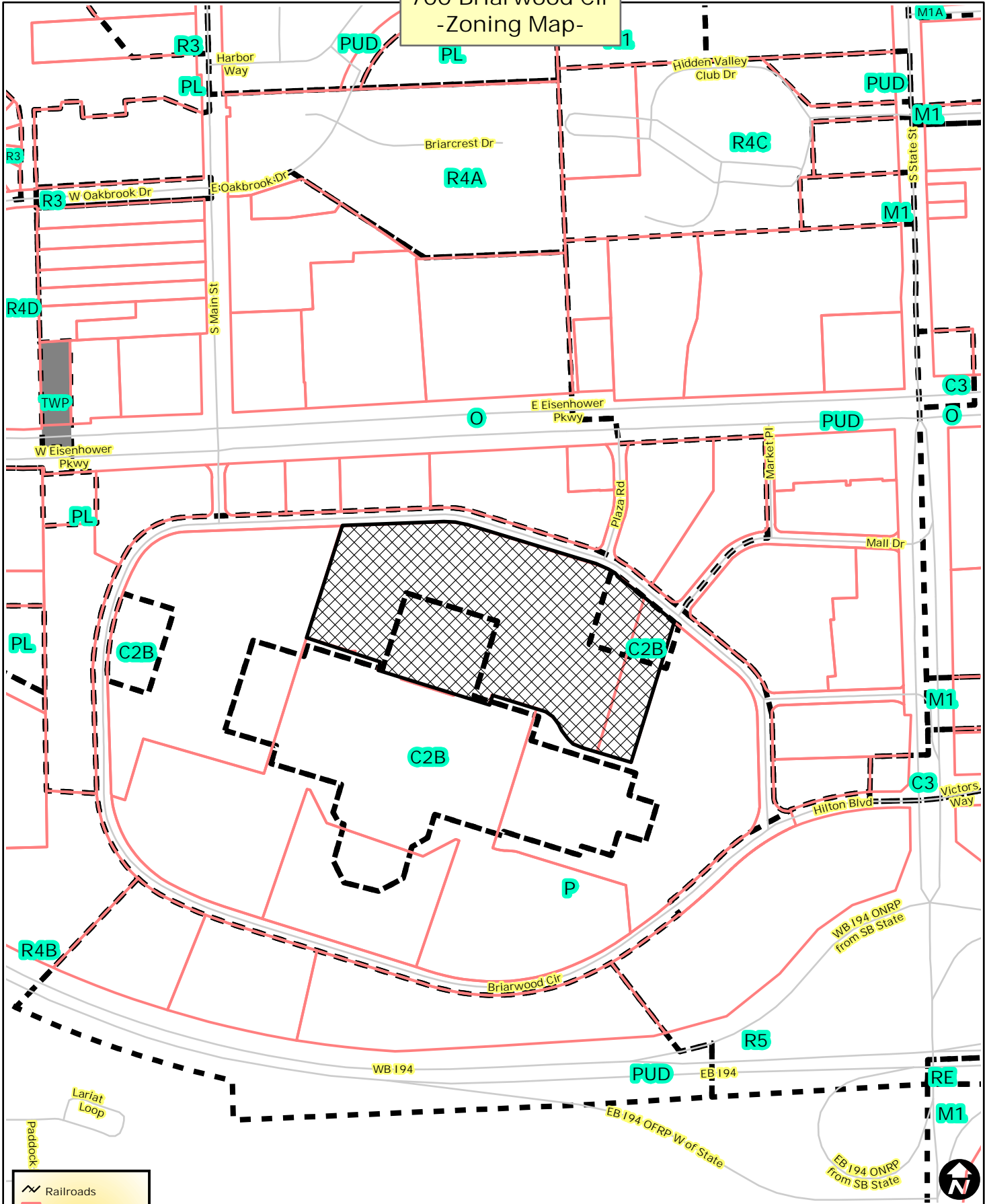
Fire  
Systems Planning  
File Nos. Z13-014 & SP13-036

# 700 Briarwood Cir -Zoning Map-



-  Railroads
-  Parcels
- Zoning**
-  Township Islands
-  Zoning Districts



City of Ann Arbor Map Disclaimer:  
 No part of this product shall be reproduced or transmitted in any form or by any means, electronic or mechanical, for any purpose, without prior written permission from the City of Ann Arbor.  
 This map complies with National Map Accuracy Standards for mapping at 1 inch = 100 Feet. The City of Ann Arbor and its mapping contractors assume no legal representation for the content and/or inappropriate use of information on this map.  
 Map Created: 10/10/2013





700 Briarwood Cir  
-Aerial Map-

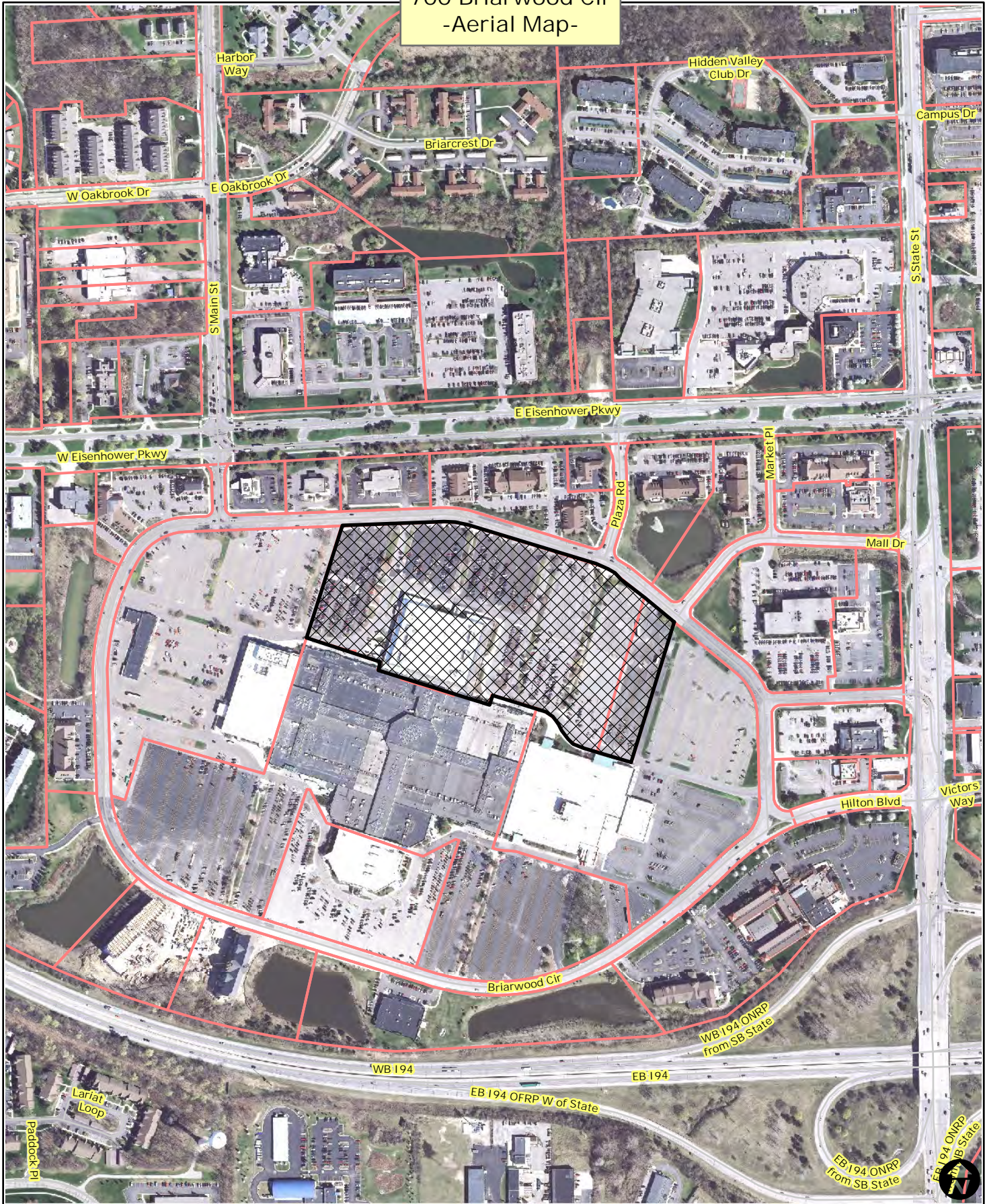

-  Railroads
-  Parcels



City of Ann Arbor Map Disclaimer:  
No part of this product shall be reproduced or transmitted in any form or by any means, electronic or mechanical, for any purpose, without prior written permission from the City of Ann Arbor.  
This map complies with National Map Accuracy Standards for mapping at 1 Inch = 100 Feet. The City of Ann Arbor and its mapping contractors assume no legal representation for the content and/or inappropriate use of information on this map.  
Map Created: 10/10/2013



9/19/2013 2:27 PM  
 HRC\_01.w.dwg  
 V:\201203\20120315\1\050\_MACYS\_Prop\_Site\_01.dwg  
 Hardin, Robert

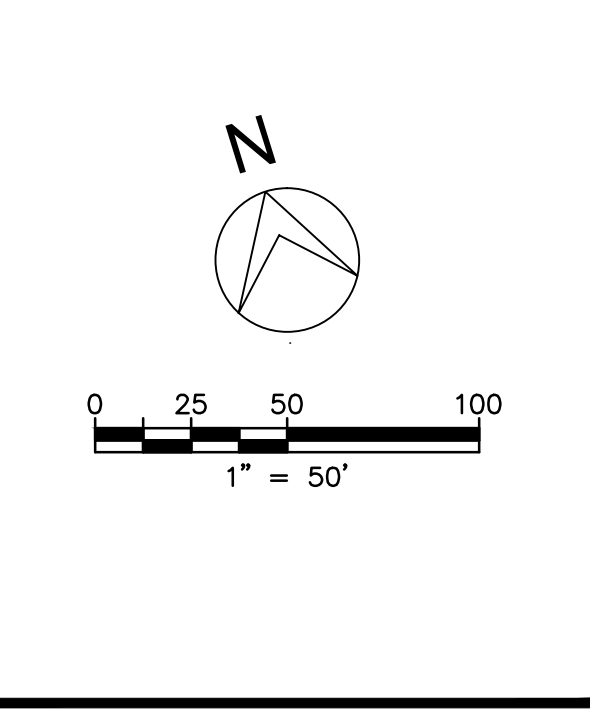
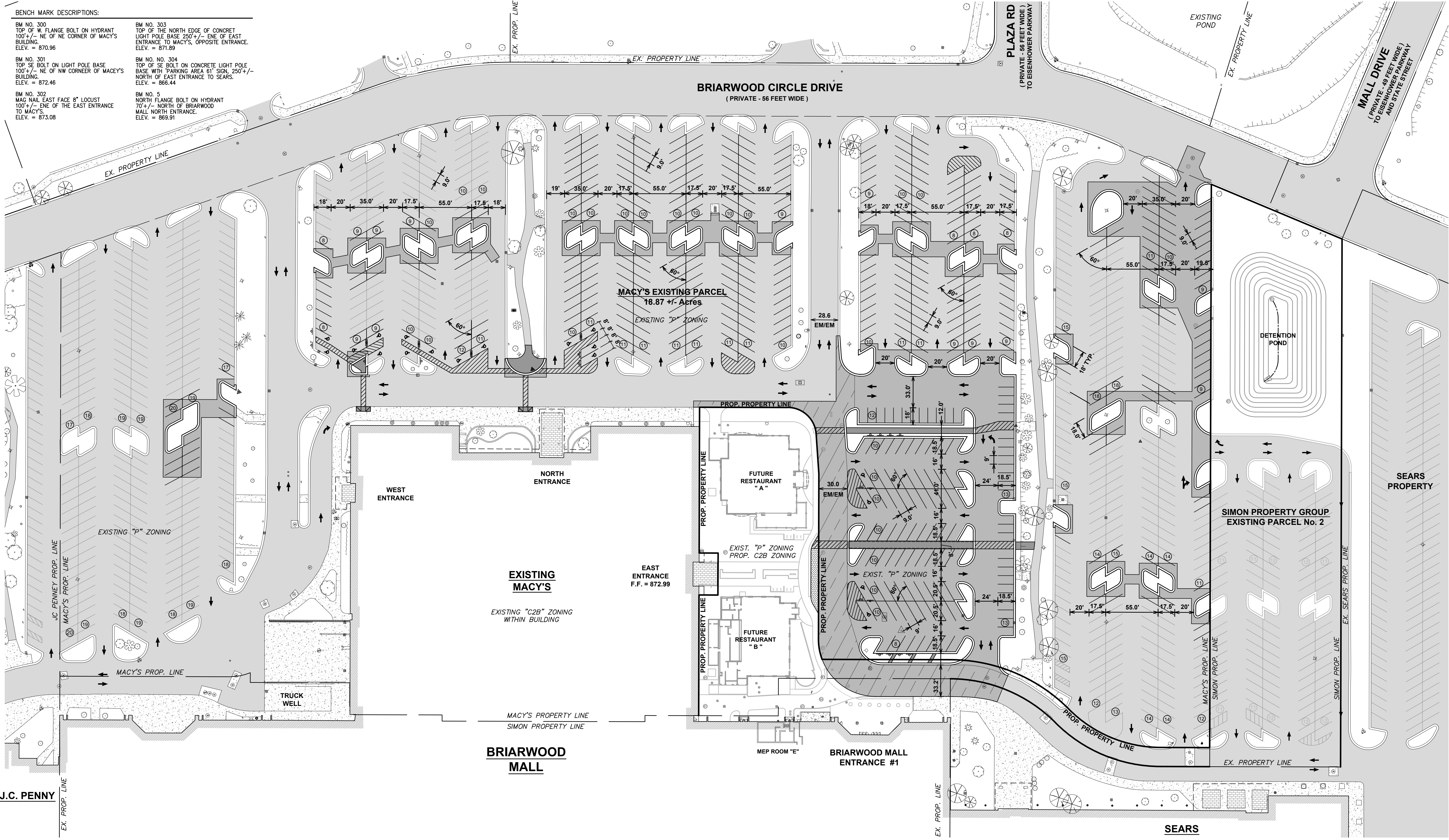

**HRC**  
 HUBBELL, ROTH & CLARK, INC.  
 Consulting Engineers  
 555 HULET DRIVE  
 BLOOMFIELD HILLS, MICH. P.O. BOX 824  
 48303 - 0824  
 PHONE: (248) 454-6300  
 FAX (1st Floor): (248) 454-6312  
 FAX (2nd Floor): (248) 438-2592  
 WEB SITE: http://www.hrc-engr.com

09.18.2013	RESUBMITTED FOR SITE PLAN
	APPROVAL
08.26.2013	SITE PLAN APPROVAL
DATE	ISSUED / ADDITIONS AND/OR REVISIONS
DESIGNED	M.G. Slicker
DRAWN	R.C. Hardin
CHECKED	G.J. Tressel
APPROVED	T.E. Biehl
V:\201203\20120315\1\050_MACYS_Prop_Site_01.dwg	

09.18.2013	RESUBMITTED FOR SITE PLAN
	APPROVAL
08.26.2013	SITE PLAN APPROVAL
DATE	ISSUED / ADDITIONS AND/OR REVISIONS
DESIGNED	M.G. Slicker
DRAWN	R.C. Hardin
CHECKED	G.J. Tressel
APPROVED	T.E. Biehl
V:\201203\20120315\1\050_MACYS_Prop_Site_01.dwg	



**MACY'S PROPOSED LEGAL DESCRIPTION**  
 A part of the North 1/2 Section 8, Town 3 South, Range 6 East, City Ann Arbor, Washtenaw County, Michigan, being more particularly described as: Commencing at the North 1/2 corner said Section 8; thence South 00 degrees 55 minutes 55 seconds East 150.13 feet along the North-South 1/4 line said Section 8 its intersection with the south right-of-way line Eisenhower Boulevard (200 feet wide); thence North 86 degrees 38 minutes 10 seconds East 41.00 feet along the south right-of-way line said Eisenhower Boulevard to a point on the east right-of-way South Main Street (49 feet wide); thence 55.14 feet along the arc of a 100.00 foot radius curve to the left, having a chord bearing South 14 degrees 12 minutes 42 seconds West 54.44 feet along said east line South Main Street; thence South 01 degrees 35 minutes 00 seconds East 117.95 feet along said east line South Main Street; thence 47.64 feet along the arc of a 30.00 foot radius curve to the left, having a chord bearing South 47 degrees 04 minutes 35 seconds East 42.79 feet along said east line South Main Street to the north right-of-way line Briarwood Circle Drive (56 feet wide); thence North 87 degrees 25 minutes 50 seconds East 175.00 feet along said north line Briarwood Circle Drive to the POINT OF BEGINNING; thence continuing North 87 degrees 25 minutes 50 seconds East 624.26 feet along said north line Briarwood Circle Drive; thence 138.94 feet along the arc of a 409.92 foot radius curve to the left, having a chord bearing North 07 degrees 08 minutes 25 seconds East 101.53 feet along said west line of Plaza Road; thence 102.02 feet along the arc of a 301.00 foot radius curve to the left, having a chord bearing North 07 degrees 08 minutes 25 seconds East 101.53 feet along said west line of Plaza Road; thence North 02 degrees 34 minutes 10 seconds West 118.61 feet along said west line of Plaza Road; thence 72.15 feet along the arc of a 100.00 foot radius curve to the left, having a chord bearing North 23 degrees 14 minutes 23 seconds West 70.60 feet along said west line of Plaza Road; thence 25.00 minutes 25 seconds West 118.06 feet along said east line of Plaza Road; thence North 16 degrees 51 minutes 09 seconds West 114.52 feet along said east line of Plaza Road; thence 40.85 feet along the arc of a 30.00 foot radius curve to the left, having a bearing South 22 degrees 09 minutes 23 seconds East 37.76 feet along said east line of Plaza Road to the north line of said Briarwood Circle Drive; thence 64.21 feet along the arc of a 349.92 foot radius curve to the right, having a chord bearing South 55 degrees 54 minutes 23 seconds East 64.12 feet along said north line of Briarwood Circle Drive; thence South 50 degrees 39 minutes 09 seconds East 190.12 feet along said north line of Briarwood Circle Drive; thence South 39 degrees 21 minutes 09 seconds West 56.00 feet to the south right-of-way line of Briarwood Circle Drive; thence North 50 degrees 39 minutes 09 seconds West 65.00 feet along said south line of Briarwood Circle Drive; thence South 16 degrees 51 minutes 09 seconds West 591.56 feet; thence North 73 degrees 09 minutes 00 seconds West 51.59 feet; thence 106.97 feet along the arc of a 136.20 foot radius curve to the right, having a chord bearing North 50 degrees 39 minutes 09 seconds West 104.24 feet; thence 138.39 feet along the arc of a 176.20 foot radius curve to the left, having a chord bearing North 50 degrees 39 minutes 09 seconds West 134.86 feet; thence North 73 degrees 09 minutes 00 seconds West 114.73 feet; thence 22.37 feet along the arc of a 60.00 foot radius curve to the right, having a chord bearing North 06 degrees 48 minutes 42 seconds East 22.24 feet; thence North 16 degrees 50 minutes 20 seconds East 172.97 feet; thence North 12 degrees 44 minutes 09 seconds East 41.85 feet; thence 44.98 feet along the arc of a 30.00 foot radius curve to the left, having a chord bearing North 30 degrees 12 minutes 45 seconds West 40.88 feet; thence North 73 degrees 09 minutes 40 seconds West 92.56 feet; thence South 16 degrees 50 minutes 20 seconds West 153.11 feet; thence South 73 degrees 09 minutes 40 seconds East 19.94 feet; thence South 17 degrees 02 minutes 13 seconds West 44.07 feet; thence North 73 degrees 09 minutes 40 seconds West 179.79 feet; thence South 16 degrees 50 minutes 20 seconds West 126.75 feet; thence North 73 degrees 09 minutes 40 seconds West 56.42 feet; thence South 16 degrees 51 minutes 09 seconds West 6.30 feet; thence North 73 degrees 09 minutes 00 seconds West 213.00 feet; thence North 16 degrees 51 minutes 09 seconds East 6.50 feet; thence North 73 degrees 09 minutes 00 seconds West 97.09 feet; thence North 16 degrees 51 minutes 09 seconds East 33.50 feet; thence North 73 degrees 09 minutes 00 seconds West 104.50 feet; thence North 16 degrees 51 minutes 09 seconds East 10.29 feet; thence 22.06 feet along the arc of a 56.00 foot radius curve to the right, having a chord bearing North 84 degrees 26 minutes 15 seconds West 21.92 feet; thence North 73 degrees 09 minutes 00 seconds West 178.50 feet; thence North 16 degrees 51 minutes 09 seconds East 445.64 feet; thence North 87 degrees 25 minutes 50 seconds West 249.65 feet; thence North 02 degrees 34 minutes 10 seconds West 56.00 feet to the POINT OF BEGINNING.

Subject to restrictions, reservations or encumbrances, if any.  
 The above described parcel contains 775,230 square feet or 17.8035 acres, more or less. Macy's - Rev 1/08-26-2013 1/09-18-2013

**LAND DEVELOPMENT REGULATIONS**

- DEVELOPMENT PROGRAM**
  - THE PROPOSED DEVELOPMENT IS FOR TWO (2) RESTAURANTS OF 7,088 SFT. and 6,470 SFT. WITH ASSOCIATED PARKING MODIFICATIONS.
  - THE PROJECT WILL BE PHASED TO PROVIDE INGRESS AND EGRESS TO ALL EXISTING ENTRANCES. ESTIMATED CONSTRUCTION COST IS \$ 1,577,094.
- COMMUNITY ANALYSIS**
  - THE PROPOSED DEVELOPMENT IS FOR TWO (2) RESTAURANTS AND WILL NOT IMPACT PUBLIC SCHOOLS.
  - THE USE IS COMPATIBLE TO THE EXISTING MALL.
  - THE EXISTING MALL IS COMPATIBLE WITH THE PROPOSED RESTAURANTS.
  - THE PROPOSED DEVELOPMENT WILL NOT IMPACT AIR AND WATER QUALITY. A SEDIMENTATION BASIN IS PROPOSED TO FILTER STORM WATER RUN OFF.
  - THERE IS NO IMPACT TO ANY HISTORIC SITES.
- NATURAL FEATURES**
  - THERE ARE NOT ANY NATURAL FEATURES AS THIS IS AN ADDITION TO AN ALREADY DEVELOPED SITE. THEREFORE, THERE WILL NOT BE ANY IMPACT. A SEDIMENTATION BASIN HAS BEEN ADDED.
- TRAFFIC IMPACT**
  - PROJECTED PEAK HOUR GENERATION RATE = 293 TRIPS / HOUR MID DAY PEAK HOUR
  - PROJECTED PEAK HOUR TRAFFIC MOVEMENTS = 166 TRIPS ENTERING / HOUR AND 127 TRIPS EXITING / HOUR MID-DAY PEAK HOUR

**MACY'S PARKING SPACES COMPARISON CHART**

EXISTING PARKING SPACES :	1,207 SPACES
EXISTING BARRIER-FREE SPACES :	30 SPACES
TOTAL EXISTING SPACES :	1,237 SPACES
PROPOSED PARKING SPACES :	1,040 SPACES
PROPOSED BARRIER-FREE SPACES :	21 SPACES
TOTAL PROPOSED SPACES :	1,061 SPACES
NET LOSS OF PARKING SPACES : (Due to Proposed Landscape / Bio-swale Islands)	176 SPACES

**COMPARISON CHART**

	EXISTING	PROPOSED	REQUIRED
ZONING CLASSIFICATION :	P	C2B	C2B
LOT AREA	N/A	6,470 Sft / 7,068 Sft	4,000 Sft Min.
FLOOR AREA	N/A	6,470 Sft / 7,068 Sft	200 % MAX.
SETBACKS - FRONT, REAR, SIDE	N/A	N/A, 10', 38.2'	10' Min., None, None
HEIGHT	N/A	25'	55' Max.
OFF STREET PARKING	N/A	25'	N/A

**LEGEND**

	EXISTING BUILDING		PROPOSED CONCRETE FACE WALK
	EXISTING ASPHALT PAVEMENT		PROPOSED CONCRETE WALK
	EXISTING CONCRETE PAVEMENT		PROPOSED HEAVY DUTY BITUMINOUS PAVEMENT
	EXISTING BRICK SIDEWALK		PROPOSED LIGHT DUTY BITUMINOUS PAVEMENT
	PROPOSED CONCRETE CURB & GUTTER		PROPOSED BRICK PAVEMENT - SEE LANDSCAPE PLANS FOR DETAILS

**3 FULL WORKING DAYS BEFORE YOU DIG**  
 CALL MISS DIG @ 1-800-482-7171  
 Member utilities are required to locate their facilities at no charge to the caller.

**NOTICE:**  
 ALL EXISTING UTILITIES SHOWN ON THIS TOPOGRAPHIC SURVEY HAVE BEEN TAKEN FROM VISUAL OBSERVATION, AND RECORD MAPPING WHERE AVAILABLE. NO GUARANTEE IS MADE, OR SHOULD BE ASSUMED, AS TO THE COMPLETENESS OR ACCURACY OF THE UTILITIES SHOWN ON THIS DRAWING. PARTIES UTILIZING THIS INFORMATION SHALL FIELD VERIFY THE ACCURACY AND COMPLETENESS PRIOR TO CONSTRUCTION ACTIVITIES.

**CITY OF ANN ARBOR**

**BRIARWOOD MALL**

WASHTENAW COUNTY MICHIGAN

**MACY'S PROPOSED SITE PLAN**

HRC JOB NO.	20120351	SCALE	1" = 50'
DATE	MARCH 2013	SHEET NO.	C 2 OF 52

© 2013 Hubbell, Roth & Clark, Inc. All Rights Reserved



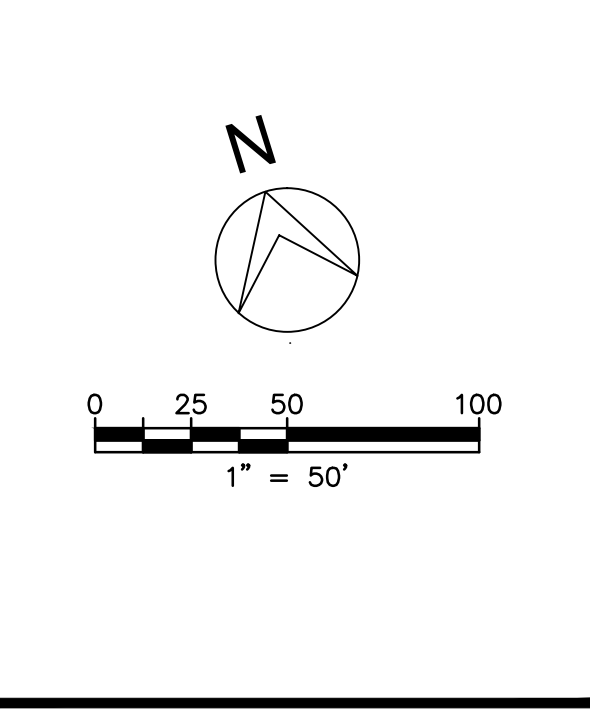
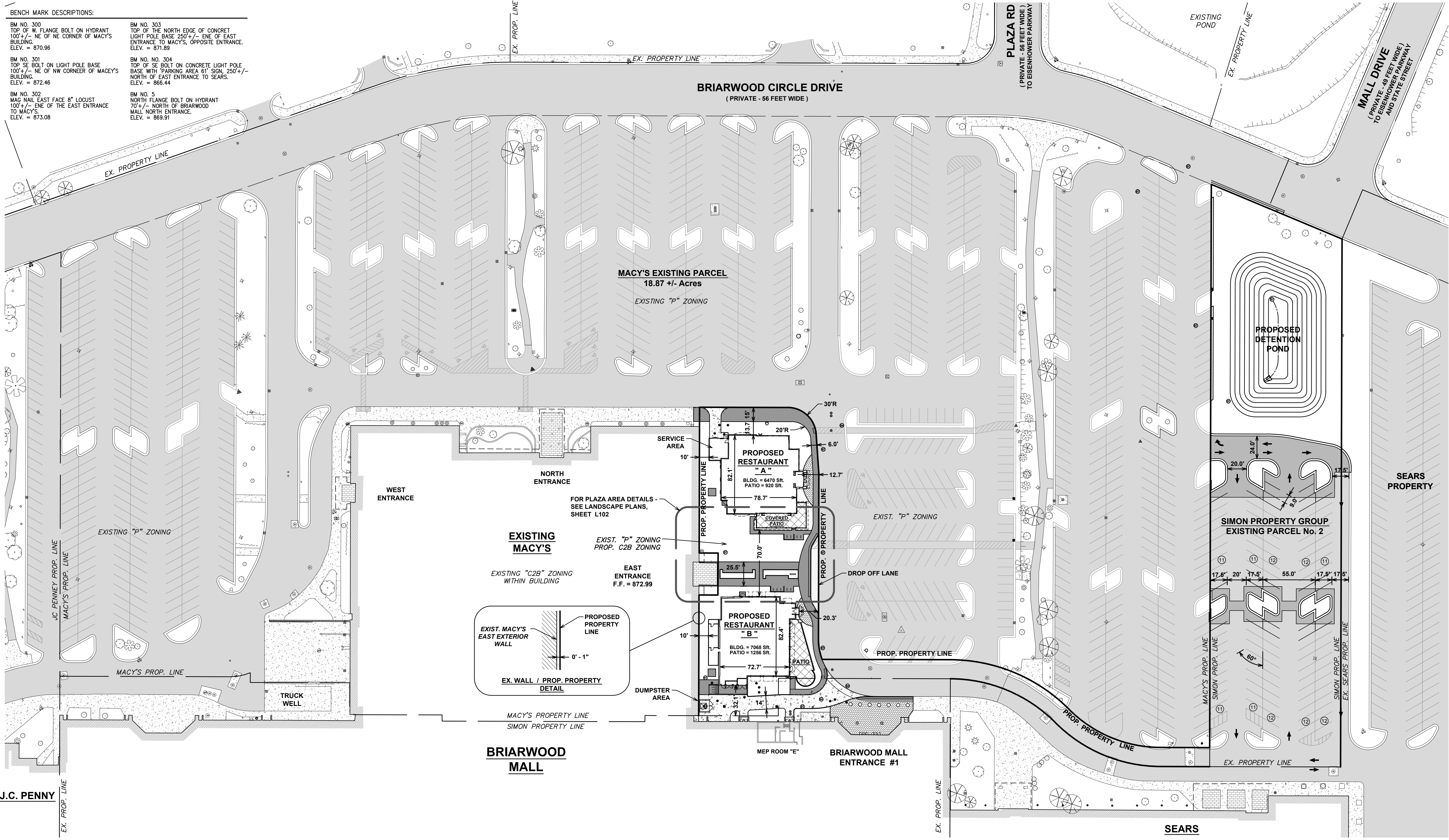

**HRC**  
HUBBELL, ROTH & CLARK, INC.  
Consulting Engineers

555 HULET DRIVE  
BLOOMFIELD HILLS, MICH. P.O. BOX 824  
48303 - 0824

PHONE: (248) 454-6300  
FAX (1st Floor): (248) 454-6312  
FAX (2nd Floor): (248) 438-2592  
WEB SITE: http://www.hrc-engr.com

09.18.2013	RESUBMITTED FOR SITE PLAN
	APPROVAL
08.26.2013	SITE PLAN APPROVAL
DATE	ISSUED / ADDITIONS AND/OR REVISIONS
DESIGNED	M.G. Slicker
DRAWN	R.C. Hardin
CHECKED	G.J. Tressel
APPROVED	T.E. Biehl
V:\201203\20120351\c050_SIMON_Prop_Site_01.dwg	

09.18.2013	RESUBMITTED FOR SITE PLAN
	APPROVAL
08.26.2013	SITE PLAN APPROVAL
DATE	ISSUED / ADDITIONS AND/OR REVISIONS
DESIGNED	M.G. Slicker
DRAWN	R.C. Hardin
CHECKED	G.J. Tressel
APPROVED	T.E. Biehl
V:\201203\20120351\c050_SIMON_Prop_Site_01.dwg	



**CITY OF ANN ARBOR**

**BRIARWOOD MALL**

WASHTENAW COUNTY MICHIGAN

**SIMON PARCEL No. 2**

**PROPOSED SITE PLAN**

HRC JOB NO. 20120351 SCALE 1" = 50'

DATE MARCH 2013 SHEET NO. C 3 OF 52

© 2013 Hubbell, Roth & Clark, Inc. All Rights Reserved

**LAND DEVELOPMENT REGULATIONS**

**1. DEVELOPMENT PROGRAM**  
a) THE PROPOSED DEVELOPMENT IS FOR TWO (2) RESTAURANTS OF 7,068 SFT. and 6,470 SFT. WITH ASSOCIATED PARKING MODIFICATIONS.

b) THE PROJECT WILL BE PHASED TO PROVIDE INGRESS AND EGRESS TO ALL EXISTING ENTRANCES. ESTIMATED CONSTRUCTION COST IS \$1,577,094.

**2. COMMUNITY ANALYSIS**  
a) THE PROPOSED DEVELOPMENT IS FOR TWO (2) RESTAURANTS AND WILL NOT IMPACT PUBLIC SCHOOLS.  
b) THE USE IS COMPATIBLE TO THE EXISTING MALL.  
c) THE EXISTING MALL IS COMPATIBLE WITH THE PROPOSED RESTAURANTS.  
d) THE PROPOSED DEVELOPMENT WILL NOT IMPACT AIR AND WATER QUALITY. A SEDIMENTATION BASIN IS PROPOSED TO FILTER STORM WATER RUN OFF.  
e) THERE IS NO IMPACT TO ANY HISTORIC SITES.

**3. NATURAL FEATURES**  
a) THERE ARE NOT ANY NATURAL FEATURES AS THIS IS AN ADDITION TO AN ALREADY DEVELOPED SITE. THEREFORE, THERE WILL NOT BE ANY IMPACT. A SEDIMENTATION BASIN HAS BEEN ADDED.

**4. TRAFFIC IMPACT**  
a) PROJECTED PEAK HOUR GENERATION RATE = 293 TRIPS / HOUR MID DAY PEAK HOUR  
b) PROJECTED PEAK HOUR TRAFFIC MOVEMENTS = 166 TRIPS ENTERING / HOUR AND 127 TRIPS EXITING / HOUR MID-DAY PEAK HOUR

**SIMON PARKING SPACES COMPARISON CHART**

EXISTING PARKING SPACES:	219 SPACES
EXISTING BARRIER-FREE SPACES:	4 SPACES
TOTAL EXISTING SPACES:	223 SPACES
PROPOSED PARKING SPACES:	111 SPACES
PROPOSED BARRIER-FREE SPACES:	4 SPACES
TOTAL PROPOSED SPACES:	115 SPACES
NET LOSS OF PARKING SPACES:	108 SPACES
(Due to Proposed Detention Pond)	

**COMPARISON CHART**

	EXISTING	PROPOSED	REQUIRED
ZONING CLASSIFICATION:	P	C2B	C2B
LOT AREA:	N/A	6,470 SR / 7,068 Sft	4,000 SR Min.
FLOOR AREA:	N/A	6,470 SR / 7,068 Sft	200 % MAX.
SETBACKS - FRONT, REAR, SIDE:	N/A	N/A, 10', 38.2'	10' Min., None, None
HEIGHT:	N/A	25'	55' Max.
OFF STREET PARKING:	N/A	25'	N/A

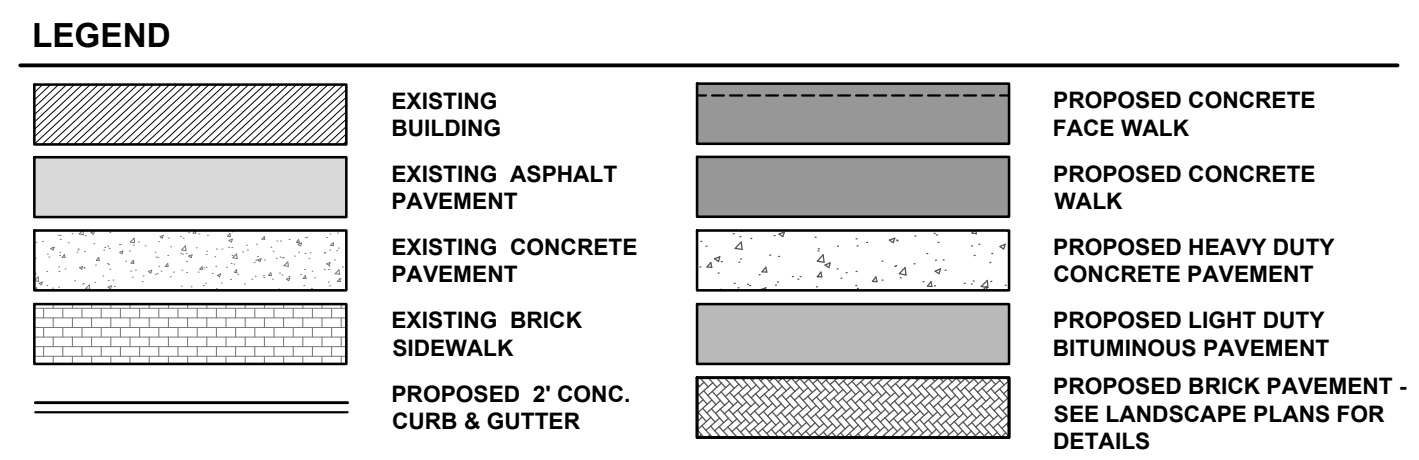

3 FULL WORKING DAYS BEFORE YOU DIG CALL MISS DIG @ 1-800-482-7171 Member utilities are required to locate their facilities at no charge to the caller.

NOTE: ALL EXISTING UTILITIES SHOWN ON THIS TOPOGRAPHIC SURVEY HAVE BEEN TAKEN FROM VISUAL OBSERVATION, AND RECORD MAPPING WHERE AVAILABLE. NO GUARANTEE IS MADE, OR SHOULD BE ASSUMED, AS TO THE COMPLETENESS OR ACCURACY OF THE UTILITIES SHOWN ON THIS DRAWING. PARTIES UTILIZING THIS INFORMATION SHALL FIELD VERIFY THE ACCURACY AND COMPLETENESS PRIOR TO CONSTRUCTION ACTIVITIES.

Subject to restrictions, reservations and easements, if any.  
The above described parcel contains 1,326,029 square feet or 30.4414 acres, more or less. Simon - NEW - Rev - 09-18-2013\08-26-2013



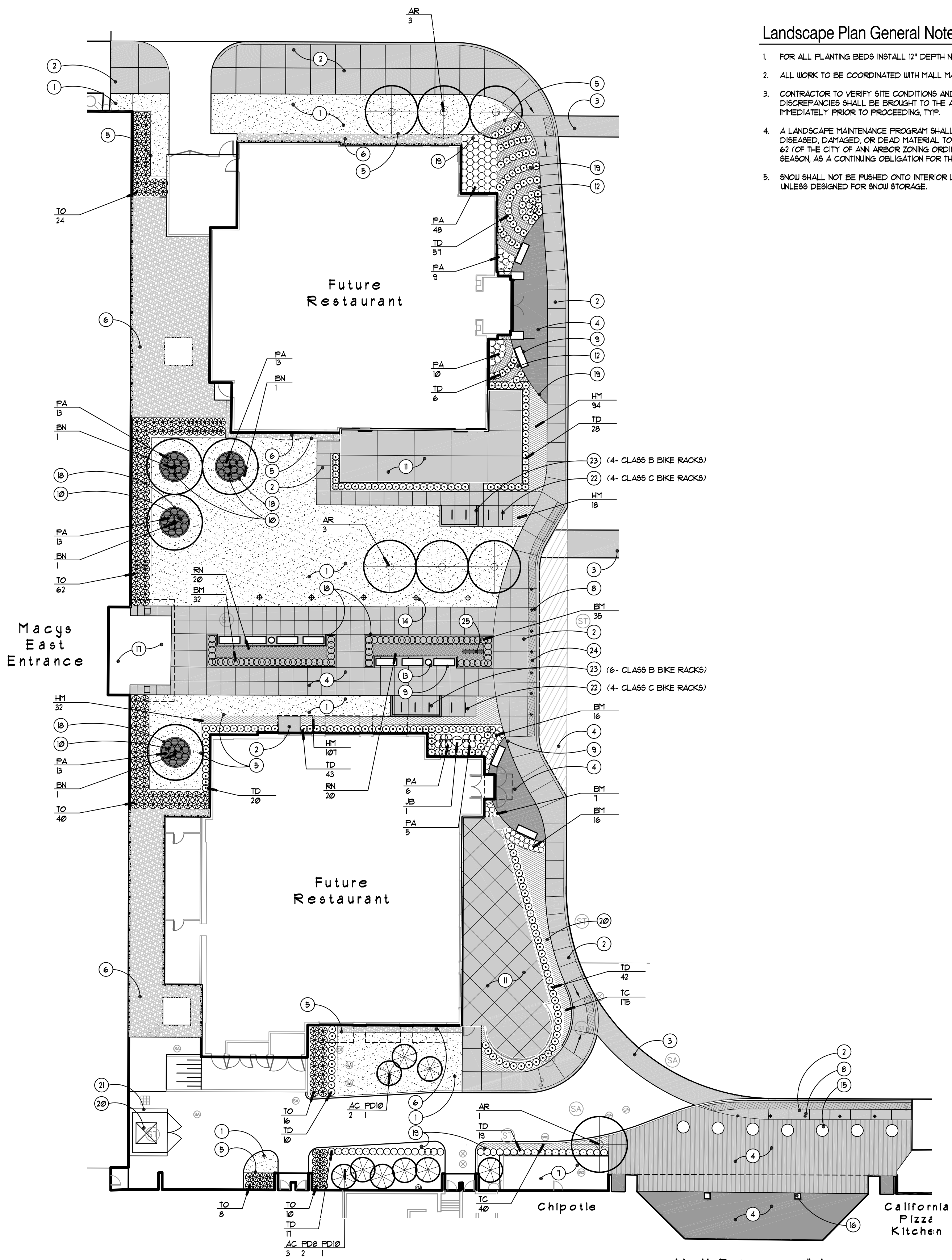

Landscape Plan General Notes:

- FOR ALL PLANTING BEDS INSTALL 12" DEPTH NEW PLANTING MIX.
- ALL WORK TO BE COORDINATED WITH MALL MANAGEMENT PRIOR TO CONSTRUCTION.
- CONTRACTOR TO VERIFY SITE CONDITIONS AND LAYOUT PRIOR TO CONSTRUCTION. ANY DISCREPANCIES SHALL BE BROUGHT TO THE ATTENTION OF THE LANDSCAPE ARCHITECT IMMEDIATELY PRIOR TO PROCEEDING, TYP.
- A LANDSCAPE MAINTENANCE PROGRAM SHALL BE IMPLEMENTED THAT WILL INCLUDE ALL DISEASED, DAMAGED, OR DEAD MATERIAL TO BE REPLACED IN ACCORDANCE WITH CHAPTER 62 (OF THE CITY OF ANN ARBOR ZONING ORDINANCE) BY THE END OF THE FOLLOWING PLANTING SEASON, AS A CONTINUING OBLIGATION FOR THE DURATION OF THE SITE PLAN.
- SNOW SHALL NOT BE PUSHED ONTO INTERIOR LANDSCAPE ISLANDS UNLESS DESIGNED FOR SNOW STORAGE.

Restaurant Pad / Plaza Hardscape / Landscape Plan Note Key:

- IRRIGATED SOODED LAWN ON 4" DEPTH TOPSOIL, TYP.
- NEW CONCRETE SIDEWALK
- CROSSWALK (REFER TO CIVIL DRAWINGS)
- DECORATIVE PAVING
- INSTALL STEEL EDGING BETWEEN LAWN AND PLANTING BEDS, TYP.
- 3" DEPTH DOUBLE-PROCESSED SHREDDED MULCH SET ON NON-WOVEN FILTER FABRIC
- EXISTING PATIO TO REMAIN
- LIGHTED BOLLARDS, TYP. (10-TOTAL)
- BENCH, TYP. (8-TOTAL)
- UPLIGHTS, TYP. 2- PER TREE (8-TOTAL)
- TENANT CONCRETE PATIO
- CRUSHED DECOMPOSED GRANITE
- LITTER RECEPTACLE (2-TOTAL)
- PEDESTRIAN LIGHT POLES, TYP. (4-TOTAL)
- CONCRETE PLANTERS WITH SEASONAL FLOWERS, TYP. (1-TOTAL)
- EXISTING COLUMNS TO REMAIN, TYP.
- EXISTING PAVERS TO REMAIN
- 4" HT. X 6" WIDE CONCRETE PLANTER CURB, TYP.
- INSTALL 3" DEPTH SHREDDED BARK MULCH IN ALL SHRUB BEDS, 1 1/2" DEPTH FOR PERENNIALS / GROUNDCOVER
- DUMPSTER (REFER TO CIVIL DRAWINGS)
- DUMPSTER ENCLOSURE (REFER TO CIVIL DRAWINGS)
- LOOP-TYPE BIKE RACKS (2 BIKES PER RACK)
- BIKE RACK SHELTER - PER CITY OF ANN ARBOR STANDARDS
- TRUNCATED DOME PADS, TYP. (FIBERGLASS PAD SYSTEM, COLOR TO BE RED)
- PROPOSED MACY'S MONUMENT SIGN

Restaurant Pad / Plaza & Overall Landscape Plant List:

CODE	QTY	DESCRIPTION	SIZE	COMMENTS
<i>Trees</i>				
AC	5	Abies concolor Concolor Fir	10' ht.	B&B, branched full to ground, unsharped
AR	7	Acer rubrum 'Marmo' Marmo Red Maple	4" cal.	B&B, matched
BN	4	Betula nigra River Birch	12-14' ht.	B&B, matched, min. 4 trunks
PD8	2	Picea glauca 'Denstata' Black Hills Spruce	8' ht.	B&B, branched full to ground, unsharped
PD10	2	Picea glauca 'Denstata' Black Hills Spruce	10' ht.	B&B, branched full to ground, unsharped
<i>Shrubs</i>				
BM	106	Buxus 'Green Velvet' Green Velvet Boxwood	18"-24" ht.	B&B, plant 24" o.c.
JB	1	Juniperus 'Blue Point' Blue Point Juniper	10' ht.	B&B, specimen unsharped
RN	40	Rosa 'Nearly Wild' Nearly Wild Rose	3-gal.	Cont., plant 30" o.c.
TD	242	Taxus 'Densiformis' Dense Yew	30" height x 30" spread	B&B, matched, plant 30" o.c., unsharped
TO	160	Thuja occidentalis 'Nigra' Nigra Arborvitae	10' ht.	B&B, matched, unsharped, plant 30" o.c.
<i>Perennials &amp; Groundcovers</i>				
HM	251	Hemerocallis 'Pardon Me' Pardon Me Daylily	1 gal.	Cont., plant 16" o.c.
PA	130	Pennisetum alopecuroides 'Hamelii' Hamelii Dwarf Fountain Grass	1 gal.	Cont., plant 24" o.c.
TC	215	Thymus praecox 'Ruby Glow' Ruby Glow Thyme	1 gal.	Cont., plant 14" o.c.
<i>Mulch</i>				
	50 cy	Double Processed Shredded Mulch		
<i>Turf</i>				
	675 sq	Lawn Area		

1 Restaurant Pad / Plaza Hardscape - Landscape Plan  
SCALE: 1" = 20'-0"

**GRISSIM MEZ ASSOCIATES ANDRIESE**  
Landscape Architecture  
300 East Cody Street  
Northville, MI 48167  
Ph: 248-347-7010  
Fax: 248-347-7005  
www.gmo-la.com

**HRC**  
HUBBELL, ROTH & CLARK, INC.  
Consulting Engineers  
555 HULET DRIVE  
BLOOMFIELD HILLS, MICH.  
P.O. BOX 824  
48303 - 0824  
PHONE: (248) 454-6300  
FAX (2nd. Floor): (248) 454-6312  
FAX (2nd. Floor): (248) 338-2592  
WEB SITE: http://www.hrc-engr.com

DATE	ADDITIONS AND/OR REVISIONS
9/18/13	PER ANN ARBOR PC REVIEW
8/26/13	SITE PLAN APPROVAL
8/19/13	OWNER REVIEW



PROJECT TITLE  
**CITY OF ANN ARBOR**  
**BRIARWOOD MALL**

WASHTENAW COUNTY MICHIGAN

SHEET TITLE  
SIMON PARCEL NO.2  
PLAZA HARDSCAPE AND  
LANDSCAPE PLAN

HRC JOB NO: 20120351  
SCALE: 1"=20'-0"

DATE: MARCH 2013  
SHEET NO: L102 OF

© 2013 Hubbell, Roth & Clark, Inc. All Rights Reserved



9/18/2013 6:08 PM

HRC\_OLM.ctb

H:\160-132 (Briarwood Mall) Dwg\Shets\160-132\_L103 -Overall Landscape\_MACYS.dwg

Scott Black

**Macy's Parking Spaces Compassion Chart**

EXISTING PARKING SPACES :	1,207 SPACES
EXISTING BARRIER-FREE SPACES :	32 SPACES
TOTAL EXISTING SPACES :	1,237 SPACES
PROPOSED PARKING SPACES :	1,040 SPACES
PROPOSED BARRIER-FREE SPACES :	21 SPACES
TOTAL PROPOSED SPACES :	1,061 SPACES
NET LOSS OF PARKING SPACES :	176 SPACES
(Due to Proposed Detention Pond)	

**Macy's Landscape Requirement Chart**

INTERIOR LANDSCAPE AREA A:	
TOTAL PROPOSED VEHICULAR USE AREA	+ 53,000 SF
TOTAL PROPOSED INTERIOR LANDSCAPE PROVIDED (DEPRESSED BIORETENTION)	+ 4,111 SF
TOTAL PROPOSED DECIDUOUS TREES PROVIDED (WITHIN DEPRESSED BIORETENTION)	+ 14 TREES
INTERIOR LANDSCAPE AREA B:	
TOTAL PROPOSED VEHICULAR USE AREA	+ 0
TOTAL PROPOSED INTERIOR LANDSCAPE PROVIDED (DEPRESSED BIORETENTION)	+ 12,536 SF
TOTAL PROPOSED DECIDUOUS TREES PROVIDED (WITHIN DEPRESSED BIORETENTION)	+ 43 TREES

**Landscape Legend:**

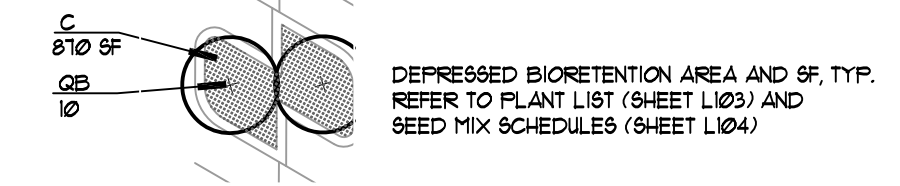

**General Notes:**

- REFER TO SHEET L104 FOR BIO-SWALE DETAIL AND TYPE A, B, & C SEED SCHEDULES.
- APPLICATIONS OF FERTILIZER BEYOND THE INITIAL TOPSOIL AND SEEDING SHALL BE FERTILIZER WITH NO PHOSPHORUS.
- SNOW STORAGE WILL BE ALONG THE INSIDE PERIMETER OF BRIARWOOD CIRCLE DRIVE (ON TO THE INTERIOR LANDSCAPE ISLANDS).
- PLANTING MIXTURE TYPE A (FOR SHRUBS AND ORNAMENTAL GRASSES): STANDARD PLANTING BACKFILL SHALL BE A MIXTURE OF 3/4 TOPSOIL, 1/4 COMPOST. ADD FERTILIZER TYPE "A" OR AS INDICATED BY SOIL TEST TO PLANTING MIXTURE PER MANUFACTURER'S REQUIREMENTS. FOLLOW PLANTING DETAILS.
- PLANTING MIXTURE TYPE B (FOR PERENNIALS, GROUND COVER BEDS AND ERICACEOUS PLANTS): PLANTING BACKFILL SHALL BE A MIXTURE OF 3/4 TOPSOIL, 1/4 COMPOST. ADDING FERTILIZER TYPE "B" OR AS INDICATED BY SOIL TEST TO MIXTURE PER MANUFACTURER REQUIREMENTS. FOLLOW PLANTING DETAILS.
- TREATMENT OF COMPACTED SOIL: CONTRACTOR TO PROVIDE PERCOLATION TESTING BY FILLING PLANT PITS WITH WATER AND MONITORING LENGTH OF TIME FOR WATER TO COMPLETELY PERCOLATE INTO SOIL. SUBMIT TEST RESULTS TO LANDSCAPE ARCHITECT PRIOR TO STARTING WORK.

**Plant List:**

CODE	QTY	DESCRIPTION	SIZE	COMMENTS
Trees				
AR	14	Acer rubrum 'Marmo'	3" cal.	B&B, matched
		Marmo Red Maple		
PO	20	Platanus occidentalis 'Bloodgood'	3" cal.	B&B, matched
		Sycamore Bloodgood		
QB	14	Quercus bicolor	3" cal.	B&B, matched
		Swamp White Oak		
UA	9	Ulmus 'Americana Princeton'	3" cal.	B&B, matched
		Princeton American Elm		
Shrubs				
RA	144	Rhus aromatica 'Gro-Low'	3 gal.	B&B, matched
		Gro-Low Sumac		plant 30" o.c.
Mulch				
		315 cy Double Processed Shredded Mulch		

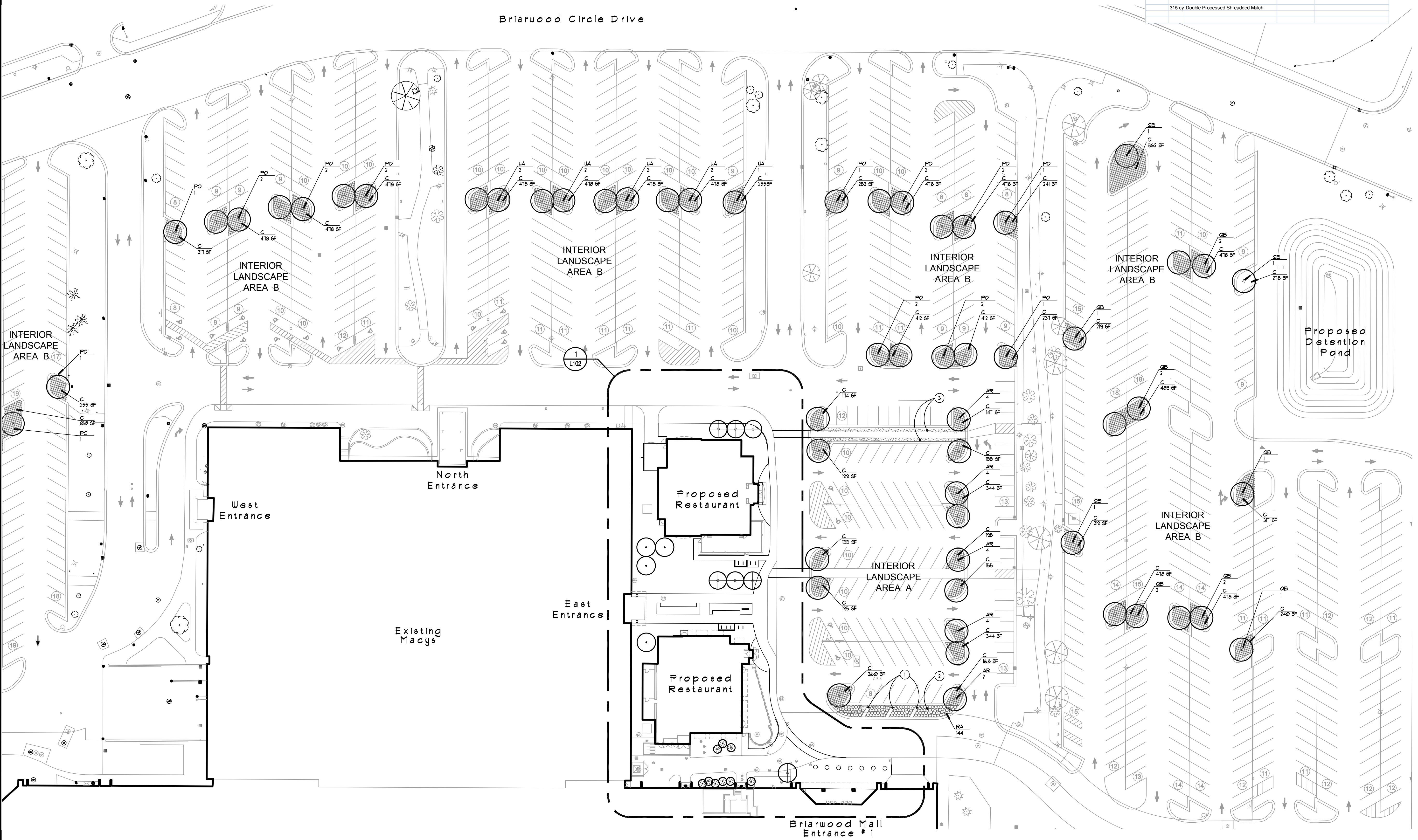

**GRISSIM MEZ ASSOCIATES ANDREISE**  
 Landscape Architecture  
 300 East Coody Street  
 Northville, MI 48167  
 Ph: 248-347-7010  
 Fax: 248-347-7005  
 www.gma-la.com

**HRC**  
 HUBBELL, ROTH & CLARK, INC.  
 Consulting Engineers  
 555 HULET DRIVE  
 BLOOMFIELD HILLS, MICH.  
 P.O. BOX 824  
 48303 - 0824  
 PHONE: (248) 454-6300  
 FAX (1st. Floor): (248) 454-6312  
 FAX (2nd. Floor): (248) 338-2592  
 WEB SITE: http://www.hrc-engr.com

9/18/13	PER ANN ARBOR PC REVIEW
8/26/13	SITE PLAN APPROVAL
8/19/13	OWNER REVIEW
DATE	ADDITIONS AND/OR REVISIONS
DESIGNED	SRB
DRAWN	SRB
CHECKED	SRB/RKM
APPROVED	RKM

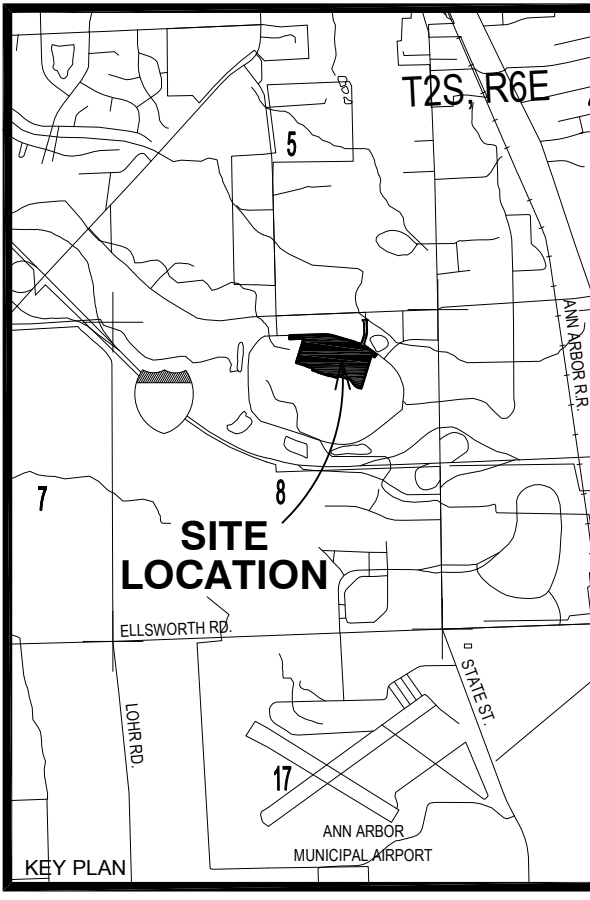

PROJECT TITLE  
**CITY OF ANN ARBOR**  
**BRIARWOOD MALL**  
 WASHTENEWAU COUNTY MICHIGAN  
 SHEET TITLE  
**MACY'S OVERALL PROPOSED LANDSCAPE PLAN**  
 HRC JOB NO. 20120351 SCALE 1"=40'-0"  
 DATE MARCH 2013 SHEET NO. L103 OF

© 2013 Hubbell, Roth & Clark, Inc. All Rights Reserved



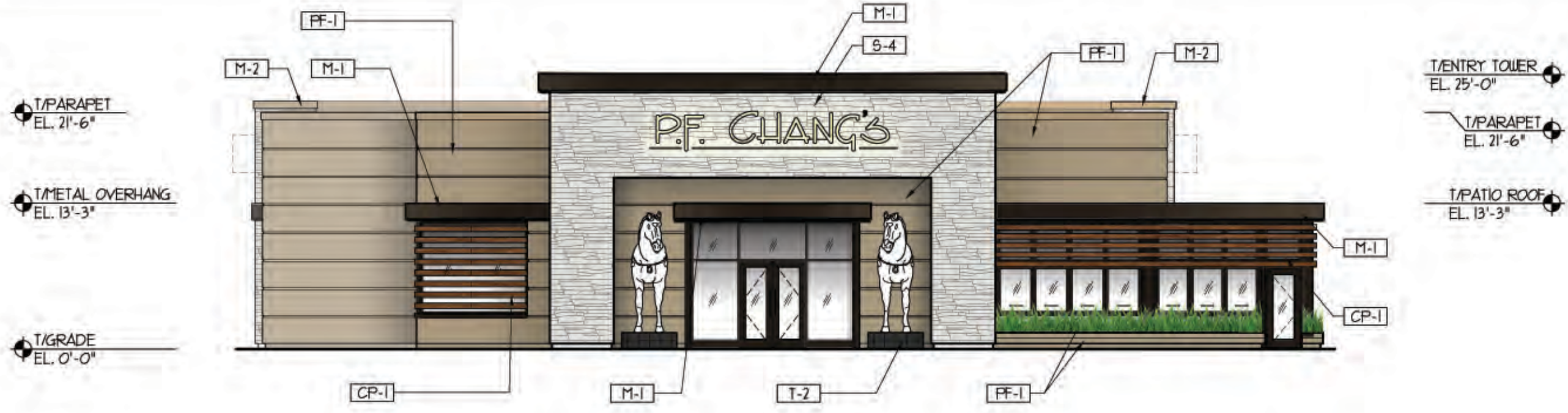

2 EAST ELEVATION

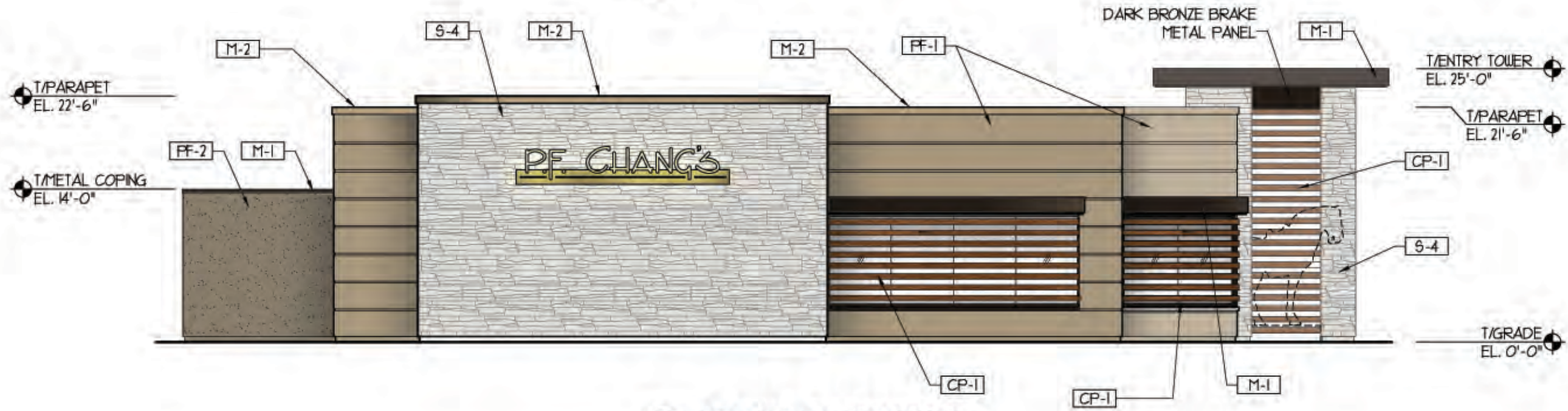

1 SOUTH ELEVATION

EXTERIOR ELEVATIONS  
SCALE: 3/32" = 1'-0"



P.F. CHANG'S  
CHINA BISTRO  
BAYBROOK MALL  
HOUSTON, TX

DESIGN DEVELOPMENT PACKAGE 2



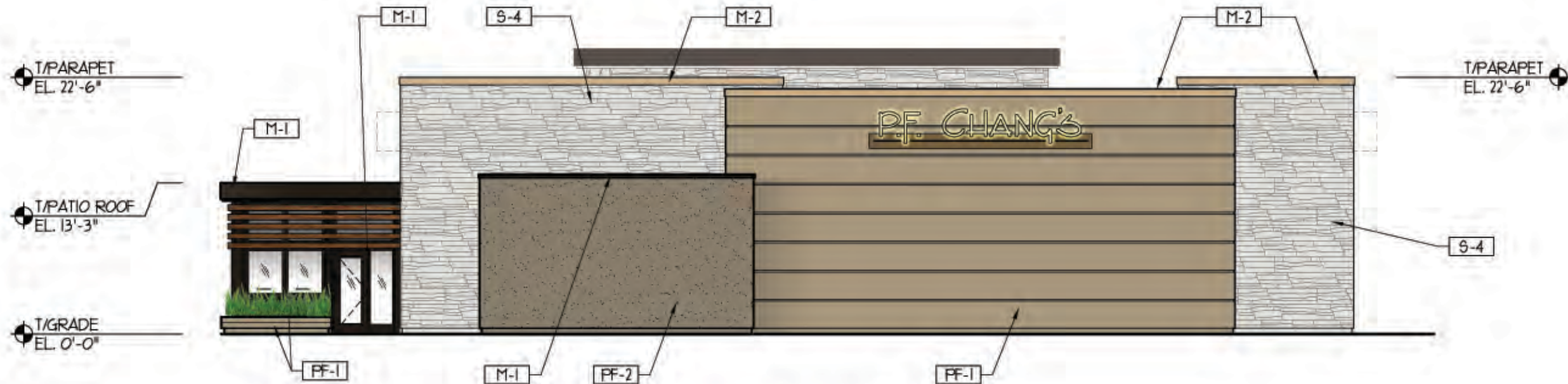

2 WEST ELEVATION

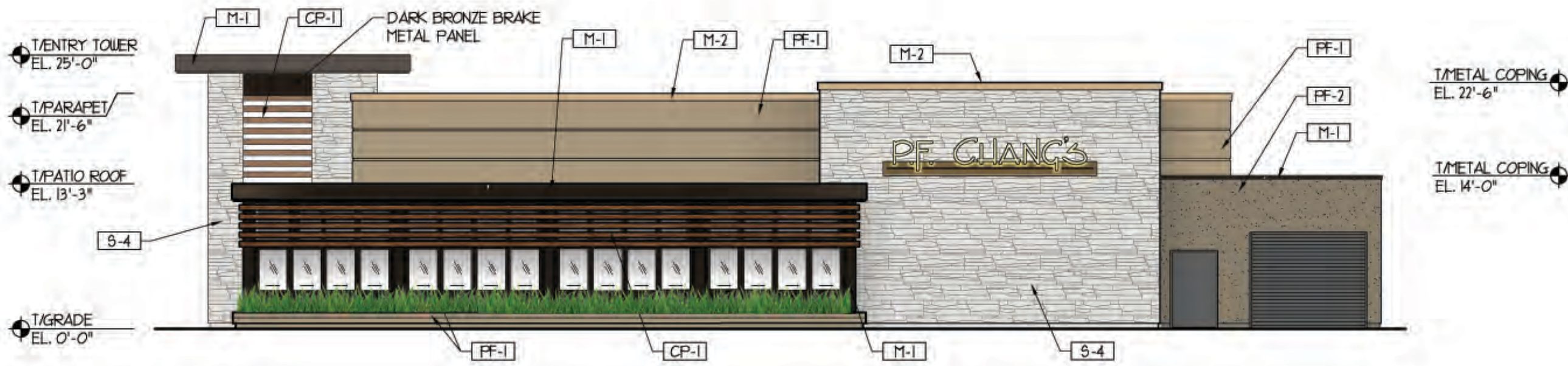

1 NORTH ELEVATION

EXTERIOR ELEVATIONS  
SCALE: 3/32" = 1'-0"



P.F. CHANG'S  
CHINA BISTRO  
BAYBROOK MALL  
HOUSTON, TX

DESIGN DEVELOPMENT PACKAGE 2



North Elevation



East Elevation



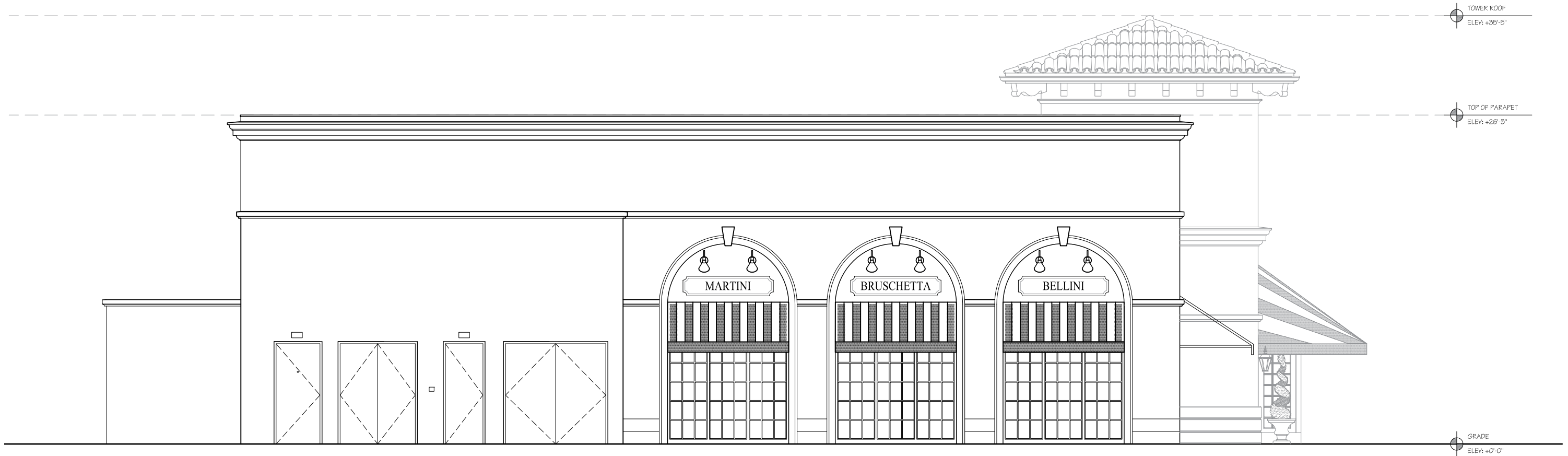

South Elevation



Briarwood Mall Expansion Citizen Participation Meeting  
Meeting Minutes

Meeting Date: Thursday, August 15, 2013

Meeting Time: 5:00 PM

Meeting Location: Briarwood Mall Community Room

Meeting Purpose: To announce Briarwood Mall expansion plans which include the addition of two restaurants and to address citizen concerns and answer questions pertaining to the proposed project

Record By: Yehmien Chou



Concern: Williams-Sonoma Stock Associate was concerned that with the restaurant build out, it would ultimately block E Dock along with the E Back Corridor. According to the Stock Associate, Williams-Sonoma receives approximately 200 to 300 boxes per delivery and that number is close to 1000 during the holiday season. Delivery vehicles need to park as close to the dock as possible.

Response: During construction, the dock will be inaccessible and the mall staff will work with individual stores to accommodate as much as possible. Contractors will be on board to keep the Dock open as much as possible and well aware that it will be an inconvenience, but hopefully, will only be for short term. Possible solutions may include using D Dock and to deliver through the mall.

Concern: Will landscape/parking lot improvements close down Ring Rd.?

Response: There will be slight traffic delays but no road closures are planned.

Concern: Was there a public hearing held for which restaurants to bid for?

Response: No, permanent leasing/development is done out of corporate office.

Concern: Why is it up close to the mall and not attached to the mall?

Response: Macy's wasn't interested in expanding.

Concern: Ann Arbor Center for Independent Living Director was concerned that shoppers with disabilities come to the mall and already have plenty of difficulties with the current layout. Will the major changes be in code with the ADA 2010 Standard? Will all handicap spaces be Van Accessible? Current spaces aren't wide enough to let people exit their vehicles. Will the website be updated with current maps including entrances, exits, walkways, etc.?

Response: New construction plans will be in code with the ADA 2010 Standard and handicapped space enhancements are included in the parking lot improvement projects. We will be putting in more Van Accessible handicap spaces along with the mall website being updated with all the appropriate, up-to-date information.

Citizen Participation Meeting Sign In Sheet – Briarwood Expansion - Thursday, August 15, 2013

NAME	ORGANIZATION	ADDRESS
Kevin Arnett	Citizen	4540 Blossom Hill Trail
RAMESH M. GANATEA	MATERIALS TESTING CONSULTANTS	(714) 619-4868 ANN ARBOR
ANDREW CLAWY	89.1 WEMU	acclawey@emich.edu 734-987-8936
JODI SIMPSON	TRIALENTMGR@GMAIL.COM	PO BOX 8102 ANN ARBOR MI 48107
MARK WINKLE	DFCU FINANCIAL	313-332-8500 400 TOWN CENTER DR DEARBORN MI 48126
Drew Lorse	Red Robin	485 Briarwood circle
Wraycrafts	annarbor.com	130 E Liberty AA 48103
Barb Fackie		514 Barton Circle
GERRY AUTH		4117 BRARVIEW CT. 48108
Jen Wilson	Perkle Vision	1051 Briarwood Circle AZ 48105
Carolyn Gorawi	Ann Arbor CIV	3941 Research Park Drive 734 971-0277 X16

**BRIARWOOD RESTAURANTS DEVELOPMENT AGREEMENT**

THIS AGREEMENT, made this \_\_\_\_ day of \_\_\_\_\_, 20\_\_, by and between the City of Ann Arbor, a Michigan Municipal Corporation, with principal address at 301 East Huron Street, Ann Arbor, Michigan 48107, hereinafter called the CITY; and Briarwood Shops, LLC, a Delaware Limited Liability Company, with principal address at 1250 E. Missouri Avenue, Phoenix, Arizona 85014, hereinafter called the PROPRIETOR, witnesses that:

WHEREAS, the PROPRIETOR owns certain land in the City of Ann Arbor, described below and site planned as Briarwood Restaurants Site Plan, and

WHEREAS, the PROPRIETOR has caused certain land in the City of Ann Arbor, described below to be surveyed, mapped and site planned as Briarwood Restaurants, and desires site plan approval, land division approval and development agreement approval thereof, and

WHEREAS, the PROPRIETOR desires to build or use certain improvements with and without the necessity of special assessments by the CITY, and

WHEREAS, the CITY desires to insure that all of the improvements required by pertinent CITY ordinances and regulations be properly made, and that the PROPRIETOR will install these improvements prior to any certificate of occupancy being issued.

**THE PROPRIETOR(S) HEREBY AGREE(S):**

(P-1) To prepare and submit to the CITY for approval plans and specifications ("the Plans") prepared by a registered professional engineer for construction of public water and sanitary sewer mains, and public and private storm water management systems ("the Improvements") provided that no work on said Improvements shall be commenced until the Plans have been approved by the City Administrator or designee, and until such other relevant information to CITY service areas as shall be reasonably required has been provided.

(P-2) To construct all improvements set forth in Paragraph P-1 of this Agreement in accordance with the approved Plans and to repair all defects in the improvements that occur within one year from the date of acceptance of the Improvements by the CITY, commencing on the latest date of the acceptance of any Improvements by the CITY. If the PROPRIETOR fails to construct the improvements, the CITY may send notice via first class mail to the PROPRIETOR at the address listed above requiring it to commence and complete the

improvements in the notice within the time set forth in the notice. The CITY may cause the work to be completed at the expense of the PROPRIETOR, if the PROPRIETOR does not complete the work within the time set forth in the notice.

(P-3) To furnish, within 30 days of completion, an engineer's certificate that the construction of the public improvements set forth in Paragraph P-1 above have been completed in accordance with the specifications of the CITY in accordance with the approved plans. The engineer's certificate will cover only those items the PROPRIETOR'S engineer inspects.

(P-4) Prior to the issuance of building permits, to deposit with a mutually acceptable escrow agent fully executed documents in a form acceptable to the CITY, which will convey, upon delivery to the CITY, easements for the construction and maintenance of public utilities. The escrow agreement shall provide for delivery of the documents to the CITY solely upon the condition that the CITY has accepted the public Improvement to be conveyed by the easement.

(P-5) To make payment in full all improvement charges to the CITY for the project's initial water service and sanitary sewer service connections. These improvement charges will be due at the time the utility services become active. The charges will be fully refunded to the PROPRIETOR upon providing verifiable evidence of water, sanitary and storm water sewer easements that were granted by the CITY permitting the PROPRIETOR to connect into the CITY's services free of charge.

(P-6) To install all water mains, storm sewers and sanitary sewers, through the first course of asphalt, pursuant to CITY approved plans and specifications, prior to the issuance of any building permits.

(P-7) To indemnify and hold the CITY harmless from any claims, losses, liabilities, damages or expenses (including reasonable attorney fees) suffered or incurred by the CITY based upon or resulting from any acts or omissions of the PROPRIETOR, its employees, agents, subcontractors, invitees, or licensees in the design, construction, maintenance or repair of any of the Improvements required under this Agreement and the approved site plan.

(P-8) To cause to be maintained General Liability Insurance and Property Damage Insurance in the minimum amount of \$1,000,000 per occurrence and naming the CITY as named insured to protect and indemnify the CITY against any claims for damage due to public use of the public improvement(s) in the development prior to final written acceptance of the public improvement(s) by the CITY. Evidence of such insurance shall be produced prior to any construction of improvement and a copy filed with the City Clerk's Office and shall remain in full force and effect during construction of the public improvement(s) and until notice of acceptance by the CITY of the Improvements.

(P-9) To prepare and submit to the Washtenaw County Water Resources Commissioner for approval storm water management measures, including the analysis report, clean-out and plans for the redesign of the existing retention pond north of Briarwood Circle Drive required to handle the storm water runoff of the proposed development prior to the issuance of any certificates of occupancy.

(P-10) To construct, repair and/or adequately maintain the off-site storm water management system. If the PROPRIETOR fails to construct, repair and/or maintain the private storm water management system, the CITY may send notice via first class mail to the



PROPRIETOR at the address listed above, requiring it to commence and complete the items stated in the notice within the time set forth in the notice. The CITY may cause the work to be completed at the expense of the PROPRIETOR if the PROPRIETOR does not complete the work within the time set forth in the notice.

(P-11) After construction of the existing off-site storm water management system, to commission an annual inspection of the system by a registered professional engineer evaluating its operation and stating required maintenance or repairs, and to provide a written copy of this evaluation to the CITY Public Services Area.

(P-12) To design, construct, repair and maintain this development in accordance with the provisions of Chapter 119 (Noise Control) to ensure that any noise emanating from said development will not impact nearby residents or businesses. In addition, PROPRIETOR shall review existing noise sources surrounding said development and incorporate necessary design and construction techniques to ensure that future tenants will not be exposed to noise sources in violation of Chapter 119.

(P-13) To remove all discarded building materials and rubbish from the development at least once each month during construction of the development improvements, and within one month after completion or abandonment of construction.

(P-14) PROPRIETOR is the sole title holder in fee simple of the land described below except for any mortgage, easements and deed restrictions of record and that the person(s) signing below on behalf of PROPRIETOR has (have) legal authority and capacity to enter into this agreement for PROPRIETOR.

(P-15) Failure to construct, repair and/or maintain the site pursuant to the approved site plan and/or failure to comply with any of this approved development agreement's terms and conditions shall constitute a material breach of the Agreement and the CITY shall have all remedies in law and/or in equity necessary to ensure that the PROPRIETOR complies with the approved site plan and/or the terms and conditions of the approved development agreement. The PROPRIETOR shall be responsible for all costs and expenses including reasonable attorney fees incurred by the CITY in enforcing the terms and conditions of the approved site plan and/or development agreement.

(P-16) In addition to any other remedy set forth in this Agreement or in law or equity, if PROPRIETOR fails to make a timely or full payments to the CITY as set forth elsewhere in the Agreement to the CITY in the agreed upon manner, any unpaid amount(s) shall become a lien, as provided under Ann Arbor City Code and recorded with the Washtenaw County Register of Deeds, against the land described below and may be placed on the CITY tax roll as a single lot assessment, or if the development is converted to condominium ownership, every owner of a portion of the property shall pay a pro-rata share of the amount of the payments attributable to each condominium unit. If the unpaid amount(s), in whole or in part, has been recorded as a lien on the CITY'S tax roll and with the Washtenaw County Register of Deeds, upon payment of the amount in full along with any penalties and interest, the CITY, upon request, will execute an instrument in recordable form acknowledging full satisfaction of this condition.

(P-17) To pay for the cost of recording this Agreement with the Washtenaw County Register of Deeds, and to pay for the cost of recording all documents granting easements to the CITY.

**THE CITY HEREBY AGREES:**

(C-1) In consideration of the above undertakings, to approve the Briarwood Restaurants Site Plan.

(C-2) To provide timely and reasonable CITY inspections as may be required during construction.

(C-3) To record this agreement with the Washtenaw County Register of Deeds.

**GENERAL TERMS**

Both the PROPRIETOR and the CITY agree as follows:

(T-1) This agreement is not intended to create a contractual right for third parties.

(T-2) This Agreement and any of its terms, conditions, or provisions cannot be modified, amended, or waived unless in writing and unless executed by both parties to this Agreement. Any representations or statements, whether oral or in writing, not contained in this Agreement shall not be binding on either party.

(T-3) This Agreement and any of its terms or conditions shall not be assigned or transferred to any other individual or entity unless prior approval of the CITY is received. Such approval shall not be withheld unreasonably.

(T-4) The obligations and conditions on the PROPRIETOR, as set forth above in this Agreement and in the approved site plan, shall be binding on any successors and assigns in ownership of the following described parcel:

A part of the North ½ of Section 8, Town 3 South, Range 6 East, City of Ann Arbor, Washtenaw County, Michigan, being more particularly described as: Commencing at the Northeast corner of said Section 8; thence South 01 degrees 39 minutes 00 seconds East 623.58 feet along the east line of said Section 8; thence North 87 degrees 39 minutes 00 seconds West 100.24 feet to the west right-of-way line of State Street; thence North 01 degrees 39 minutes 00 seconds West 25.24 feet along said west right-of-way line of State Street for a POINT OF BEGINNING; thence 26.12 feet along the arc of a 70.00 foot radius curve to the left, having a chord bearing North 76 degrees 57 minutes 33 seconds West 25.97 feet; thence North 87 degrees 39 minutes 00 seconds West 466.08 feet; thence 185.00 feet along the arc of a 200.00 foot radius curve to the left, having a chord bearing South 65 degrees 51 minutes 00 seconds West 178.48 feet; thence South 39 degrees 21 minutes 00 seconds West 224.47 feet; thence 47.12 feet along the arc of a 30.00 foot radius curve to the left, having a chord bearing South 05 degrees 39 minutes 00 seconds East 42.43 feet; thence North 50 degrees 39 minutes 00 seconds West 33.89 feet; thence South 39 degrees 21 minutes 00 seconds West 56.00 feet; thence South 16 degrees 51 minutes 00 seconds West 554.62 feet; thence North 73 degrees 09 minutes 00

seconds West 189.09 feet; thence 122.68 feet along the arc of a 156.20 foot radius curve to the right, having a chord bearing North 50 degrees 39 minutes 00 seconds West 119.55 feet; thence 122.68 feet along the arc of a 156.20 foot radius curve to the left, having a chord bearing North 50 degrees 39 minutes 00 seconds West 119.55 feet; thence North 73 degrees 09 minutes 00 seconds West 180.50 feet; thence South 16 degrees 50 minutes 57 seconds West 39.50 feet; thence North 73 degrees 09 minutes 00 seconds West 83.58 feet; thence North 16 degrees 50 minutes 20 seconds East 126.75 feet; thence South 73 degrees 09 minutes 40 seconds East 19.79 feet; thence North 17 degrees 02 minutes 13 seconds East 44.07 feet; thence North 73 degrees 09 minutes 40 seconds West 19.94 feet; thence North 16 degrees 50 minutes 20 seconds East 153.11 feet; thence South 73 degrees 09 minutes 40 seconds East 92.56 feet; thence 44.98 feet along the arc of a 30.00 foot radius curve to the right, having a chord bearing South 30 degrees 12 minutes 45 seconds East 40.88 feet; thence South 12 degrees 44 minutes 09 seconds West 41.85 feet; thence South 16 degrees 50 minutes 20 seconds West 172.97 feet; thence 22.37 feet along the arc of a 60.01 foot radius curve to the left, having a chord bearing South 06 degrees 48 minutes 42 seconds West 22.24 feet; thence South 73 degrees 09 minutes 00 seconds East 134.73 feet; thence 138.39 feet along the arc of a 176.20 foot radius curve to the right, having a chord bearing South 50 degrees 39 minutes 00 seconds East 134.86 feet; thence 106.97 feet along the arc of a 136.20 foot radius curve to the left, having a chord bearing South 50 degrees 39 minutes 00 seconds East 104.24 feet; thence South 73 degrees 09 minutes 00 seconds East 51.59 feet; thence North 16 degrees 51 minutes 00 seconds East 591.56 feet; thence South 50 degrees 39 minutes 00 seconds East 65.00 feet; thence North 39 degrees 21 minutes 00 seconds East 56.00 feet thence South 50 degrees 39 minutes 00 seconds East 8.70 feet; thence 47.12 feet along the arc of a 30.00 foot radius curve to the left, having a chord bearing North 84 degrees 21 minutes 00 seconds East 42.43 feet; thence North 39 degrees 21 minutes 00 seconds East 224.47 feet; thence 187.96 feet along the arc of a 249.00 foot radius curve to the right, having a chord bearing North 60 degrees 58 minutes 30 seconds East 183.53 feet; thence 44.11 feet along the arc of a 30.00 foot radius curve to the left, having a chord bearing North 40 degrees 28 minutes 30 seconds East 40.25 feet; thence North 01 degrees 39 minutes 00 seconds West 339.49 feet to the south right-of-way line of Eisenhower Parkway; thence North 87 degrees 25 minutes 50 seconds East 31.00 feet along said south right-of-way of Eisenhower Parkway; thence South 01 degrees 39 minutes 00 seconds East 342.31 feet; thence 45.03 feet along the arc of a 30.00 foot radius curve to the left, having a chord bearing South 44 degrees 39 minutes 00 seconds East 40.92 feet; thence South 87 degrees 39 minutes 00 seconds East 265.91 feet; thence North 88 degrees 54 minutes 00 seconds East 99.70 feet; thence South 87 degrees 39 minutes 00 seconds East 44.02 feet; thence 35.61 feet along the arc of a 60.00 foot radius curve to the left, having a chord bearing North 75 degrees 21 minutes 00 seconds East 35.09 feet to the said west right-of-way line of State Street; thence South 01 degrees 39 minutes 00 seconds East 70.25 feet along the said west right-of-way line of State Street to the POINT OF BEGINNING.

Subject to restrictions, reservations, and easements, if any.

(T-5) In addition to any other remedy in law or in equity failure to comply with all of the above paragraphs on the part of the PROPRIETOR, or any part of the approved site plan, in part or in whole, shall give the CITY adequate basis and cause to issue a stop work order for

any previously-issued building permits and shall be an adequate basis and cause for the CITY to deny the issuance of any building permits, certificates of occupancy, or any other permits unless and until the CITY has notified the PROPRIETOR in writing that the PROPRIETOR has satisfactorily corrected the item(s) the PROPRIETOR has failed to perform.

(T-6) This agreement shall be interpreted, enforced and governed under the laws of the State of Michigan and Ann Arbor City Code.

IN WITNESS WHEREOF, the parties hereto have set their hands and seals the day first above written.

Witnesses:

\_\_\_\_\_

CITY OF ANN ARBOR, MICHIGAN  
301 East Huron Street  
Ann Arbor, Michigan 48107

By: \_\_\_\_\_  
John Hieftje, Mayor

\_\_\_\_\_

By: \_\_\_\_\_  
Jacqueline Beaudry, City Clerk

Approved as to Substance:

\_\_\_\_\_  
Steven D. Powers, City Administrator

Approved as to Form:

\_\_\_\_\_  
Stephen K. Postema, City Attorney

Witness:

\_\_\_\_\_

By: \_\_\_\_\_  
*Name, Title*

STATE OF MICHIGAN )  
 ) ss:  
County of Washtenaw )

On this \_\_\_\_\_ day of \_\_\_\_\_, 20\_\_, before me personally appeared John Hieftje, Mayor, and Jacqueline Beaudry, Clerk of the City of Ann Arbor, a Michigan Municipal Corporation, to me known to be the persons who executed this foregoing instrument, and to me known to be such Mayor and Clerk of said Corporation, and acknowledged that they executed the foregoing instrument as such officers as the free act and deed of said Corporation by its authority.

\_\_\_\_\_  
NOTARY PUBLIC  
County of Washtenaw, State of Michigan  
My Commission Expires: \_\_\_\_\_  
Acting in the County of Washtenaw

STATE OF MICHIGAN )  
 ) ss:  
County of Washtenaw )

On this \_\_\_\_\_ day of \_\_\_\_\_, 20\_\_, before me personally appeared \_\_\_\_\_, to me known to be the person who executed the foregoing instrument, and acknowledged that he executed the foregoing instrument as his free act and deed.

\_\_\_\_\_  
NOTARY PUBLIC  
County of Washtenaw, State of Michigan  
My Commission Expires: \_\_\_\_\_  
Acting in the County of Washtenaw

DRAFTED BY AND AFTER RECORDING RETURN TO:  
Ann Arbor Planning & Development Services  
Post Office Box 8647  
Ann Arbor, Michigan 48107  
(734) 794-6265





11/13/2013 5:41 PM

HRC\_cdw.ctb

V:\201203\20120315\050\_MACYS\_Prop\_Site\_01.dwg  
Hardin Robert

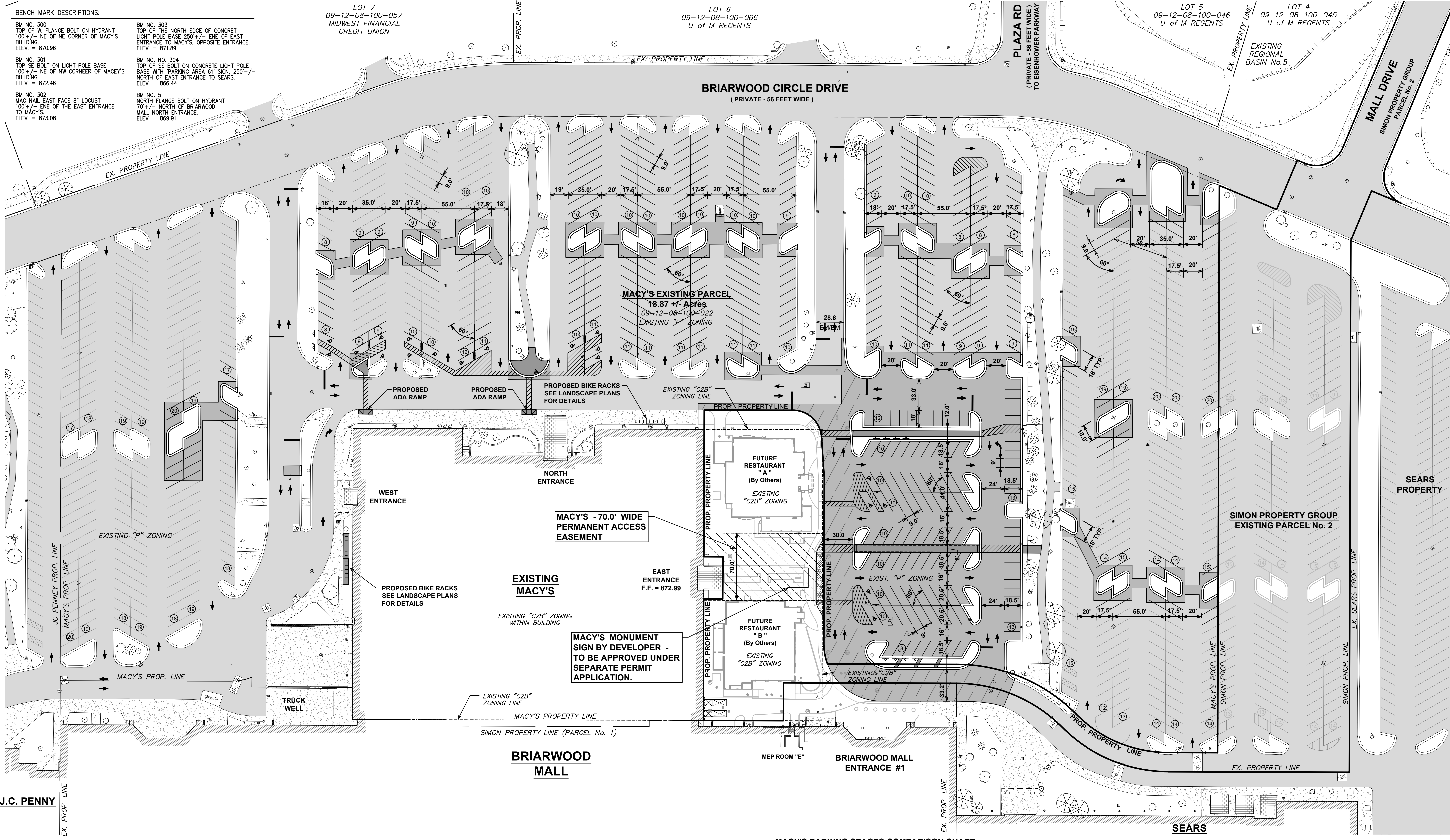

**BENCH MARK DESCRIPTIONS:**

BM NO. 300 TOP OF W FLANGE BOLT ON HYDRANT 100' +/- NE OF NE CORNER OF MACY'S BUILDING. ELEV. = 870.96	BM NO. 303 TOP OF THE NORTH EDGE OF CONCRETE LIGHT POLE BASE 250' +/- ENE OF EAST ENTRANCE TO MACY'S, OPPOSITE ENTRANCE. ELEV. = 871.89
BM NO. 301 TOP SE BOLT ON LIGHT POLE BASE 100' +/- NE OF NW CORNER OF MACY'S BUILDING. ELEV. = 872.46	BM NO. 304 TOP OF SE BOLT ON CONCRETE LIGHT POLE BASE WITH PARKING AREA 61 SIGN, 250' +/- NORTH OF EAST ENTRANCE TO SEARS. ELEV. = 866.44
BM NO. 302 MAG NAIL EAST FACE 8" LOCUST 100' +/- ENE OF THE EAST ENTRANCE TO MACY'S. ELEV. = 873.08	BM NO. 5 NORTH FLANGE BOLT ON HYDRANT 70' +/- NORTH OF BRIARWOOD MALL NORTH ENTRANCE. ELEV. = 869.91

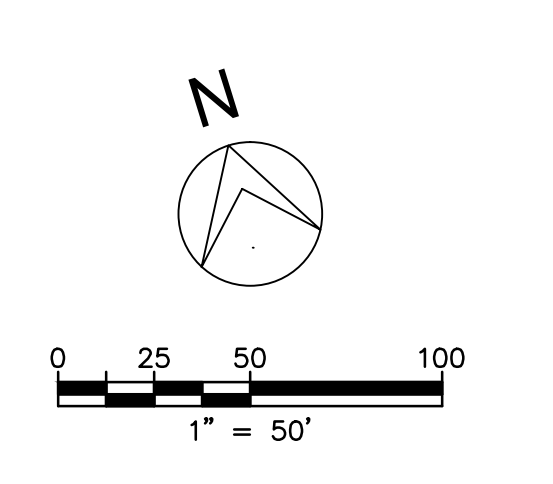

**SIMON** PROPERTY GROUP, INC.  
225 W. Washington St.  
Indianapolis, IN 46204  
(317) 263-4664

**HRC**  
HUBBELL, ROTH & CLARK, INC.  
Consulting Engineers  
555 HULET DRIVE  
BLOOMFIELD HILLS, MICH. P.O. BOX 824  
48303 - 0824  
PHONE: (248) 454-6300  
FAX (1st Floor): (248) 454-6312  
WEB SITE: <http://www.hrc-enr.com>

11-08-2013	RESUBMITTED FOR SITE PLAN APPROVAL
10-18-2013	FOR BIDS
10-10-2013	PER CITY'S COMMENTS
10-09-2013	PER MACY'S COMMENTS
09-18-2013	RESUBMITTED FOR SITE PLAN APPROVAL
08-26-2013	SITE PLAN APPROVAL
DATE	ISSUED / ADDITIONS AND/OR REVISIONS
DESIGNED	M.G. Slicker
DRAWN	R.C. Hardin
CHECKED	G.J. Tressel
APPROVED	T.E. Biehl
V:\201203\20120315\050_MACYS_Prop_Site_01.dwg	

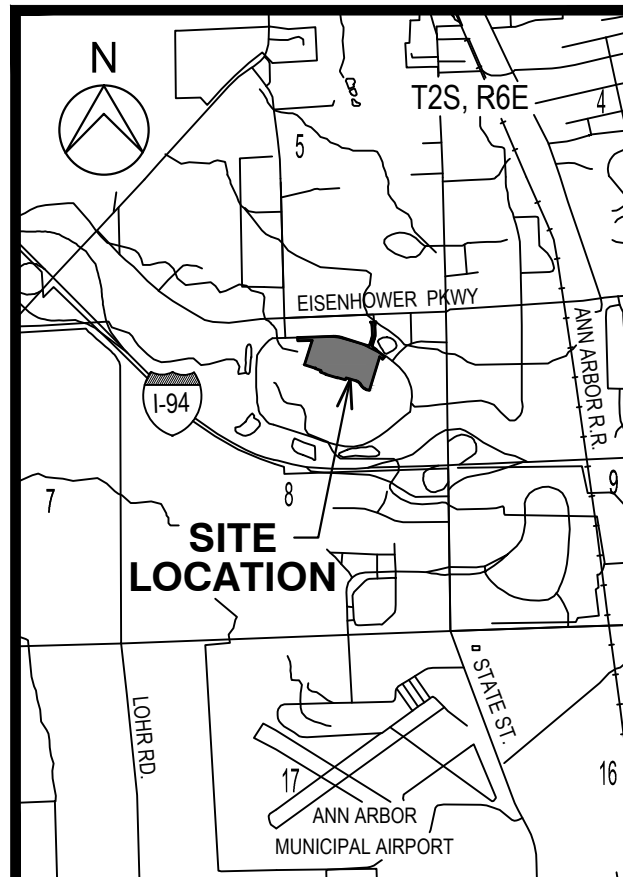

**CITY OF ANN ARBOR**

**BRIARWOOD MALL RESTAURANT EXPANSION**

WASHTENAW COUNTY MICHIGAN

**MACY'S PROPOSED SITE PLAN**

HRC JOB NO. 20120351 SCALE 1" = 50'

DATE MARCH 2013 SHEET NO. C 2 OF 62

© 2013 Hubbell, Roth & Clark, Inc. All Rights Reserved

**MACY'S PROPOSED LEGAL DESCRIPTION**

A part of the North 1/4 Section 8, Town 3 South, Range 6 East, City Ann Arbor, Washtenaw County, Michigan, being more particularly described as Commencing at the North 1/4 corner said Section 8; thence South 00 degrees 55 seconds East 150.13 feet along the North-South 1/4 line said Section 8 to its intersection with the North-South right-of-way line Eisenhower Boulevard (200 feet wide); thence North 86 degrees 38 minutes 10 seconds East 41.00 feet along the north right-of-way line said Eisenhower Boulevard to a point on the east right-of-way South Main Street (49 feet wide); thence 55.14 feet along the arc of a 100.00 foot radius curve to the left, having a chord bearing South 14 degrees 12 minutes 42 seconds West 54.44 feet along said east line South Main Street; thence South 01 degrees 35 minutes 00 seconds East 117.95 feet along said east line South Main Street; thence 47.64 feet along the arc of a 30.00 foot radius curve to the left, having a chord bearing South 47 degrees 04 minutes 35 seconds East 42.79 feet along said east line South Main Street to the north right-of-way line of Briarwood Circle Drive (56 feet wide); thence North 87 degrees 25 minutes 50 seconds East 175.00 feet along said north line Briarwood Circle Drive to the POINT OF BEGINNING; thence continuing North 87 degrees 25 minutes 50 seconds East 624.26 feet along said north line Briarwood Circle Drive; thence 138.94 feet along the arc of a 409.92 foot radius curve to the left, having a chord bearing North 07 degrees 09 minutes 25 seconds East 101.53 feet along said west line of Plaza Road; thence North 02 degrees 34 minutes 10 seconds West 118.61 feet along said west line of Plaza Road; thence 72.15 feet along the arc of a 100.00 foot radius curve to the left, having a chord bearing North 23 degrees 14 minutes 10 seconds West 70.60 feet along said west line of Plaza Road to the south line of said Eisenhower Parkway; thence North 86 degrees 38 minutes 10 seconds East 89.55 feet along the said south line of Eisenhower Parkway to east right-of-way line of Plaza Road; thence 56.65 feet along the arc of a 100.00 foot radius curve to the left, having a chord bearing South 13 degrees 39 minutes 30 seconds West 55.89 feet along said east line of Plaza Road; thence South 02 degrees 34 minutes 10 seconds East 132.24 feet along said east line of Plaza Road; thence 118.63 feet along the arc of a 350.00 foot radius curve to the right, having a bearing South 07 degrees 08 minutes 25 seconds West 118.60 feet along said east line of Plaza Road; thence North 16 degrees 51 minutes 09 seconds West 114.52 feet along said east line of Plaza Road; thence 40.85 feet along the arc of a 30.00 foot radius curve to the left, having a bearing South 22 degrees 09 minutes 23 seconds East 37.76 feet along said east line of Plaza Road to the north line of said Briarwood Circle Drive; thence 64.21 feet along the arc of a 349.92 foot radius curve to the right, having a chord bearing South 55 degrees 54 minutes 23 seconds East 64.12 feet along said north line of Briarwood Circle Drive; thence South 50 degrees 39 minutes 09 seconds East 190.12 feet along said north line of Briarwood Circle Drive; thence South 39 degrees 21 minutes 00 seconds West 56.00 feet to the south right-of-way line of Briarwood Circle Drive; thence North 50 degrees 39 minutes 09 seconds West 65.00 feet along said south line of Briarwood Circle Drive; thence South 16 degrees 51 minutes 09 seconds West 591.56 feet; thence North 73 degrees 09 minutes 00 seconds West 51.59 feet; thence 106.97 feet along the arc of a 136.20 foot radius curve to the right, having a chord bearing North 50 degrees 39 minutes 09 seconds West 104.24 feet; thence 138.39 feet along the arc of a 176.20 foot radius curve to the left, having a chord bearing North 50 degrees 39 minutes 09 seconds West 134.86 feet; thence North 73 degrees 09 minutes 00 seconds West 114.73 feet; thence 22.37 feet along the arc of a 60.00 foot radius curve to the right, having a chord bearing North 06 degrees 48 minutes 42 seconds East 22.24 feet; thence North 16 degrees 51 minutes 09 seconds East 172.97 feet; thence North 12 degrees 44 minutes 09 seconds East 41.85 feet; thence 44.98 feet along the arc of a 30.00 foot radius curve to the left, having a chord bearing North 20 degrees 12 minutes 45 seconds West 40.88 feet; thence North 73 degrees 09 minutes 00 seconds West 92.56 feet; thence South 16 degrees 59 minutes 20 seconds West 153.11 feet; thence South 73 degrees 09 minutes 40 seconds East 19.94 feet; thence South 17 degrees 02 minutes 13 seconds West 44.07 feet; thence North 73 degrees 09 minutes 40 seconds West 179.79 feet; thence South 16 degrees 59 minutes 20 seconds West 126.75 feet; thence North 12 degrees 44 minutes 09 seconds East 56.42 feet; thence South 16 degrees 51 minutes 09 seconds West 6.30 feet; thence North 73 degrees 09 minutes 00 seconds West 213.00 feet; thence North 16 degrees 51 minutes 09 seconds East 6.50 feet; thence North 73 degrees 09 minutes 00 seconds West 97.00 feet; thence North 16 degrees 51 minutes 09 seconds East 33.50 feet; thence North 73 degrees 09 minutes 00 seconds West 104.50 feet; thence North 16 degrees 51 minutes 09 seconds East 10.29 feet; thence 22.06 feet along the arc of a 56.00 foot radius curve to the right, having a chord bearing North 84 degrees 26 minutes 15 seconds West 21.92 feet; thence North 73 degrees 09 minutes 00 seconds West 178.50 feet; thence North 16 degrees 51 minutes 09 seconds East 445.64 feet; thence North 87 degrees 25 minutes 50 seconds West 249.65 feet; thence North 02 degrees 34 minutes 10 seconds West 56.00 feet to the POINT OF BEGINNING.

Subject to restrictions, reservations or easements, if any. Macy's - Rev 1/08-26-2013 1/09-18-2013

**LAND DEVELOPMENT REGULATIONS**

1. DEVELOPMENT PROGRAM

a) THE PROPOSED DEVELOPMENT IS FOR TWO (2) RESTAURANTS OF 7,088 SFT. AND 6,470 SFT. WITH ASSOCIATED PARKING MODIFICATIONS.

b) THE PROJECT WILL BE PHASED TO PROVIDE INGRESS AND EGRESS TO ALL EXISTING ENTRANCES. ESTIMATED CONSTRUCTION COST IS \$ 1,577,094.

2. COMMUNITY ANALYSIS

a) THE PROPOSED DEVELOPMENT IS FOR TWO (2) RESTAURANTS AND WILL NOT IMPACT PUBLIC SCHOOLS.

b) THE USE IS COMPATIBLE TO THE EXISTING MALL.

c) THE EXISTING MALL IS COMPATIBLE WITH THE PROPOSED RESTAURANTS.

d) THE PROPOSED DEVELOPMENT WILL NOT IMPACT AIR AND WATER QUALITY. A SEDIMENTATION BASIN IS PROPOSED TO FILTER STORM WATER RUN OFF. THERE IS NO IMPACT TO ANY HISTORIC SITES.

3. NATURAL FEATURES

a) THERE ARE NOT ANY NATURAL FEATURES AS THIS IS AN ADDITION TO AN ALREADY DEVELOPED SITE. THEREFORE, THERE WILL NOT BE ANY IMPACT. A SEDIMENTATION BASIN HAS BEEN ADDED.

4. TRAFFIC IMPACT

a) PROJECTED PEAK HOUR GENERATION RATE = 293 TRIPS / HOUR MID DAY PEAK HOUR

b) PROJECTED PEAK HOUR TRAFFIC MOVEMENTS = 166 TRIPS ENTERING / HOUR AND 127 TRIPS EXITING / HOUR MID-DAY PEAK HOUR

**MACY'S PARKING SPACES COMPARISON CHART**

EXISTING PARKING SPACES :	1,207 SPACES
EXISTING BARRIER-FREE SPACES :	30 SPACES
TOTAL EXISTING SPACES :	1,237 SPACES
PROPOSED PARKING SPACES :	1,042 SPACES
PROPOSED BARRIER-FREE SPACES :	22 SPACES
TOTAL PROPOSED SPACES :	1,064 SPACES
NET LOSS OF PARKING SPACES :	173 SPACES

(Due to Proposed Landscape / Bio-swale Installations)

NOTE: PARKING WILL NOT EXCEED PREVIOUSLY APPROVED NUMBER OF 1,237 SPACES.

**COMPARISON CHART**

	EXISTING	PROPOSED	REQUIRED
Zoning :	P	C2B	C2B
Gross Lot Area :	18.87 Acres	17.80 Acres	N/A
Maximum Usable Floor Area in Percentage of Lot Area :	23%	25%	200% Max.
Front (East) :	516'	0.083'	0'
Side (South) :	0.083'	N/A	None
Rear (West) :	304.65'	N/A	None
Height :	35'	N/A	55' Maximum
Parking - Automobiles :	1,237 Spaces	1,064 Spaces *	934
Parking - Bicycles :	N/A	20 B & 20 C = 40 26 Deferred	66

\* No Small Car Provided

**NOTE :**  
NO NEW FIRE WALLS ARE BEING BUILT AS A PART OF THIS CONSTRUCTION

**LEGEND**

EXISTING BUILDING	PROPOSED CONCRETE FACE WALK
EXISTING ASPHALT PAVEMENT	PROPOSED CONCRETE WALK
EXISTING CONCRETE PAVEMENT	PROPOSED HEAVY DUTY BITUMINOUS PAVEMENT
EXISTING BRICK SIDEWALK	PROPOSED LIGHT DUTY BITUMINOUS PAVEMENT
PROPOSED CONCRETE CURB & GUTTER	PROPOSED DECORATIVE PAVING - REFER TO LANDSCAPE DRAWINGS

3 FULL WORKING DAYS BEFORE YOU DIG CALL MISS DIG @ 1-800-482-7171

Member utilities are required to locate their facilities at no charge to the caller.

NOTE: ALL EXISTING UTILITIES SHOWN ON THIS TOPOGRAPHIC SURVEY HAVE BEEN TAKEN FROM VISUAL OBSERVATION, AND RECORD MAPPING WHERE AVAILABLE. NO GUARANTEE IS MADE, OR SHOULD BE ASSUMED, AS TO THE COMPLETENESS OR ACCURACY OF THE UTILITIES SHOWN ON THIS DRAWING. PARTIES UTILIZING THIS INFORMATION SHALL FIELD VERIFY THE ACCURACY AND COMPLETENESS PRIOR TO CONSTRUCTION ACTIVITIES.



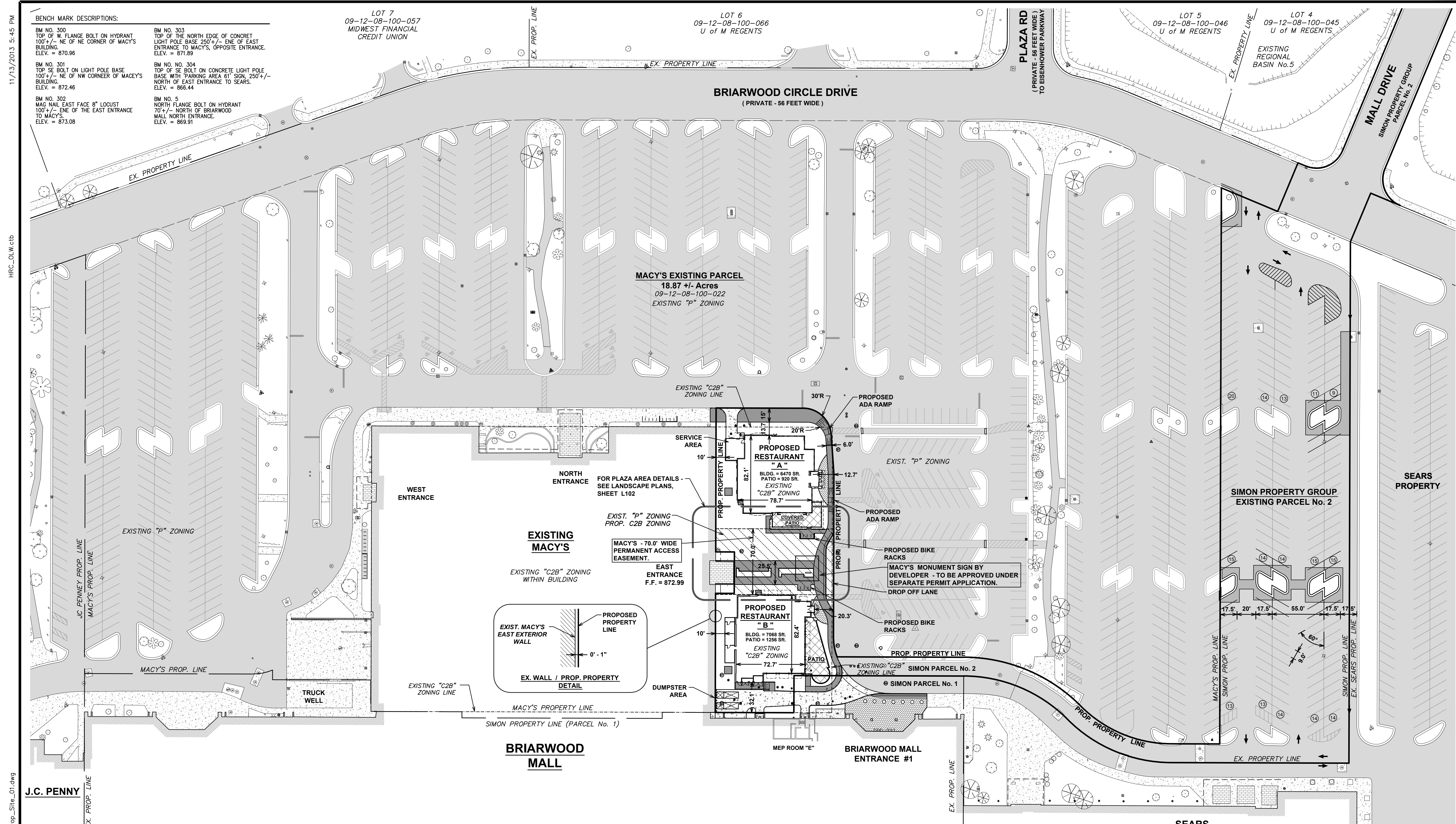

11/13/2013 5:45 PM  
HRC.dwg.ctb

V:\201203\20120315\1\c050\_SIMON\_Prop\_Site\_01.dwg  
Hardin Robert

**BENCH MARK DESCRIPTIONS:**  
 BM NO. 300  
 TOP OF W. FLANGE BOLT ON HYDRANT  
 100' +/- NE OF NE CORNER OF MACY'S  
 BUILDING.  
 ELEV. = 870.96  
 BM NO. 301  
 TOP SE BOLT ON LIGHT POLE BASE  
 100' +/- NE OF NW CORNER OF MACY'S  
 BUILDING.  
 ELEV. = 872.46  
 BM NO. 302  
 MAG NAIL EAST FACE 8" LOCUST  
 100' +/- ENE OF THE EAST ENTRANCE  
 TO MACY'S.  
 ELEV. = 873.08  
 BM NO. 303  
 TOP OF THE NORTH EDGE OF CONCRETE  
 LIGHT POLE BASE 250' +/- ENE OF EAST  
 ENTRANCE TO MACY'S, OPPOSITE ENTRANCE.  
 ELEV. = 871.89  
 BM NO. 304  
 TOP OF SE BOLT ON CONCRETE LIGHT POLE  
 BASE WITH PARKING AREA 61' SIGN, 250' +/-  
 NORTH OF EAST ENTRANCE TO SEARS.  
 ELEV. = 866.44  
 BM NO. 5  
 NORTH FLANGE BOLT ON HYDRANT  
 70' +/- NORTH OF BRIARWOOD  
 MALL NORTH ENTRANCE.  
 ELEV. = 869.91

**LOT 7**  
 09-12-08-100-057  
 MIDWEST FINANCIAL  
 CREDIT UNION

**LOT 6**  
 09-12-08-100-066  
 U OF M REGENTS

**LOT 5**  
 09-12-08-100-046  
 U OF M REGENTS

**LOT 4**  
 09-12-08-100-045  
 U OF M REGENTS

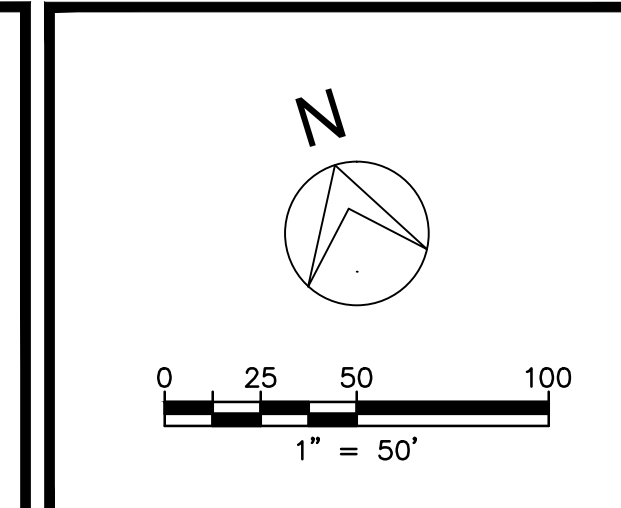

**SIMON** PROPERTY GROUP, INC.  
 225 W. Washington St.  
 Indianapolis, IN 46204  
 (317) 263-4664

**HRC**  
 HUBBELL, ROTH & CLARK, INC.  
 Consulting Engineers  
 555 HULET DRIVE  
 BLOOMFIELD HILLS, MICH. P.O. BOX 824  
 48303 - 0824  
 PHONE: (248) 454-6300  
 FAX (1st Floor): (248) 454-6312  
 WEB SITE: http://www.hrc-enr.com

DATE	ISSUED / ADDITIONS AND/OR REVISIONS
11-08-2013	RESUBMITTED FOR SITE PLAN APPROVAL
10-18-2013	FOR BIDS
10-10-2013	PER CITY'S COMMENTS
10-09-2013	PER CITY'S COMMENTS
09-18-2013	RESUBMITTED FOR SITE PLAN APPROVAL
08-26-2013	SITE PLAN APPROVAL

DESIGNED: M.G. Slicker  
 DRAWN: R.C. Hardin  
 CHECKED: G.J. Tressel  
 APPROVED: T.E. Biehl

V:\201203\20120315\1\c050\_SIMON\_Prop\_Site\_01.dwg

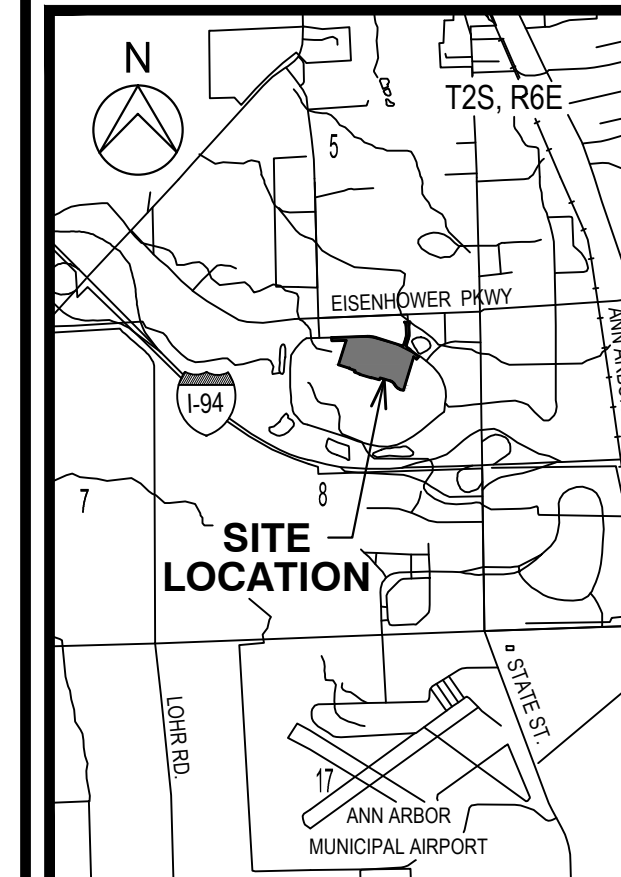

**CITY OF ANN ARBOR**  
**BRIARWOOD MALL**  
**RESTAURANT EXPANSION**  
 WASHTENAW COUNTY MICHIGAN  
**SIMON PARCEL No. 2**  
**PROPOSED SITE PLAN**

HRC JOB NO. 20120351 SCALE 1" = 50'  
 DATE MARCH 2013 SHEET NO. C 3 OF 62

**SIMON PARKING SPACES COMPARISON CHART**

EXISTING PARKING SPACES :	219 SPACES
EXISTING BARRIER-FREE SPACES :	4 SPACES
TOTAL EXISTING SPACES :	223 SPACES
PROPOSED PARKING SPACES :	204 SPACES
PROPOSED BARRIER-FREE SPACES :	4 SPACES
TOTAL PROPOSED SPACES :	208 SPACES

NET LOSS OF PARKING SPACES : 15 SPACES  
 (Due to Proposed Landscaping / Bio-swale islands)  
 NOTE: PARKING WILL NOT EXCEED PREVIOUSLY APPROVED NUMBER OF 223 SPACES.

**COMPARISON CHART**

Zoning :	EXISTING	PROPOSED	REQUIRED
Zoning :	P	C2B	C2B
Gross Lot Area :	1.84 Acres	2.91 Acres	2.91 Acres
Maximum Usable Floor Area In Percentage Of Lot Area	N/A	12%	200% Max.
Front (East)	N/A	12.7'	0'
Side (South)	N/A	32.1'	None
Rear (West)	N/A	10'	None
Height :	N/A	25'	55' Maximum
Parking - Automobiles :	223 Spaces	208 Spaces *	-
Parking - Bicycles :	0	6 B & 6 C = 12	18

\* No Small Car Provided

**NOTE :**  
 NO NEW FIRE WALLS ARE BEING BUILT AS A PART OF THIS CONSTRUCTION

**LEGEND**

EXISTING BUILDING	PROPOSED CONCRETE FACE WALK
EXISTING ASPHALT PAVEMENT	PROPOSED CONCRETE WALK
EXISTING CONCRETE PAVEMENT	PROPOSED HEAVY DUTY CONCRETE PAVEMENT
EXISTING BRICK SIDEWALK	PROPOSED LIGHT DUTY BITUMINOUS PAVEMENT
PROPOSED 2" CONC. CURB & GUTTER	PROPOSED DECORATIVE PAVING - REFER TO LANDSCAPE DRAWINGS

3 FULL WORKING DAYS BEFORE YOU DIG CALL MISS DIG @ 1-800-482-7171  
 Member utilities are required to locate their facilities at no charge to the caller.

NOTE: ALL EXISTING UTILITIES SHOWN ON THIS TOPOGRAPHIC SURVEY HAVE BEEN TAKEN FROM VISUAL OBSERVATION, AND RECORD MAPPING WHERE AVAILABLE. NO GUARANTEE IS MADE, OR SHOULD BE ASSUMED, AS TO THE COMPLETENESS OR ACCURACY OF THE UTILITIES SHOWN ON THIS DRAWING. PARTIES UTILIZING THIS INFORMATION SHALL FIELD VERIFY THE ACCURACY AND COMPLETENESS PRIOR TO CONSTRUCTION ACTIVITIES.

**LAND DEVELOPMENT REGULATIONS**

- DEVELOPMENT PROGRAM**
  - THE PROPOSED DEVELOPMENT IS FOR TWO (2) RESTAURANTS OF 7,068 SFT. and 6,470 SFT. WITH ASSOCIATED PARKING MODIFICATIONS.
  - THE PROJECT WILL BE PHASED TO PROVIDE INGRESS AND EGRESS TO ALL EXISTING ENTRANCES. ESTIMATED CONSTRUCTION COST IS \$1,577,094.
- COMMUNITY ANALYSIS**
  - THE PROPOSED DEVELOPMENT IS FOR TWO (2) RESTAURANTS AND WILL NOT IMPACT PUBLIC SCHOOLS.
  - THE USE IS COMPATIBLE TO THE EXISTING MALL.
  - THE EXISTING MALL IS COMPATIBLE WITH THE PROPOSED RESTAURANTS.
  - THE PROPOSED DEVELOPMENT WILL NOT IMPACT AIR AND WATER QUALITY. A SEDIMENTATION BASIN IS PROPOSED TO FILTER STORM WATER RUN OFF.
  - THERE IS NO IMPACT TO ANY HISTORIC SITES.
- NATURAL FEATURES**
  - THERE ARE NOT ANY NATURAL FEATURES AS THIS IS AN ADDITION TO AN ALREADY DEVELOPED SITE. THEREFORE, THERE WILL NOT BE ANY IMPACT. A SEDIMENTATION BASIN HAS BEEN ADDED.
- TRAFFIC IMPACT**
  - PROJECTED PEAK HOUR GENERATION RATE = 293 TRIPS / HOUR MID DAY PEAK HOUR
  - PROJECTED PEAK HOUR TRAFFIC MOVEMENTS = 166 TRIPS ENTERING / HOUR AND 127 TRIPS EXITING / HOUR MID-DAY PEAK HOUR

**SIMON PROPOSED LEGAL DESCRIPTION**

A part of the North 1/2 of Section 8, Town 3 South, Range 6 East, City of Ann Arbor, Washtenaw County, Michigan, being more particularly described as: Commencing at the North 1/2 corner of said Section 8, thence South 00 degrees 56 minutes 55 seconds East 150.13 feet along the North-South 1/2 line of said Section 8 to its intersection with the south right-of-way line of Eisenhower Parkway (200 feet wide); thence North 86 degrees 38 minutes 10 seconds East 41.00 feet along the south right-of-way line of said Eisenhower Parkway to a point on the east right-of-way of South Main Street (69 feet wide); thence 55.14 feet along the arc of a 100.00 foot radius curve to the left, having a chord bearing South 14 degrees 12 minutes 42 seconds West 54.44 feet along said east line of South Main Street; thence South 01 degree 35 minutes 00 seconds East 117.95 feet along said east line of South Main Street; thence 47.64 feet along the arc of a 30.00 foot radius curve to the left, having a chord bearing South 47 degrees 04 minutes 33 seconds East 42.79 feet along said east line of South Main Street to the north right-of-way line of Briarwood Circle Drive (56 feet wide); thence North 87 degrees 25 minutes 50 seconds East 175.00 feet along said north line of Briarwood Circle Drive; thence South 02 degrees 34 minutes 10 seconds East 56.00 feet; thence North 87 degrees 25 minutes 50 seconds East 249.65 feet; thence South 16 degrees 51 minutes 00 seconds West 465.64 feet a POINT OF BEGINNING; thence South 73 degrees 09 minutes 00 seconds East 178.50 feet; thence 22.06 feet along the arc of a 56.00 foot radius curve to the left, having a chord bearing South 84 degrees 26 minutes 15 seconds East 21.02 feet; thence South 16 degrees 51 minutes 00 seconds West 10.29 feet; thence South 73 degrees 09 minutes 00 seconds East 104.50 feet; thence South 16 degrees 51 minutes 00 seconds West 33.50 feet; thence South 73 degrees 09 minutes 00 seconds East 97.00 feet; thence South 16 degrees 51 minutes 00 seconds West 6.50 feet; thence South 73 degrees 09 minutes 00 seconds East 213.00 feet; thence North 16 degrees 51 minutes 00 seconds East 6.50 feet; thence South 73 degrees 09 minutes 00 seconds East 56.42 feet; thence North 16 degrees 50 minutes 20 seconds East 126.75 feet; thence South 73 degrees 09 minutes 00 seconds East 19.79 feet; thence North 17 degrees 02 minutes 13 seconds East 44.07 feet; thence North 73 degrees 09 minutes 00 seconds West 19.94 feet; thence North 16 degrees 50 minutes 20 seconds East 153.11 feet; thence South 73 degrees 09 minutes 00 seconds East 92.56 feet; thence 44.98 feet along the arc of a 30.00 foot radius curve to the right, having a chord bearing South 30 degrees 12 minutes 45 seconds East 40.88 feet; thence South 12 degrees 44 minutes 09 seconds West 41.85 feet; thence North 16 degrees 50 minutes 20 seconds East 126.75 feet; thence North 16 degrees 51 minutes 00 seconds East 153.11 feet; thence South 73 degrees 09 minutes 00 seconds East 44.07 feet; thence 42.50 feet along the arc of a 30.00 foot radius curve to the right, having a chord bearing South 50 degrees 50 minutes 00 seconds East 39.24 feet; thence South 73 degrees 09 minutes 00 seconds East 134.73 feet; thence 138.39 feet along the arc of a 176.20 foot radius curve to the right, having a chord bearing South 50 degrees 39 minutes 00 seconds East 134.86 feet; thence 106.97 feet along the arc of a 136.20 foot radius curve to the left, having a chord bearing South 50 degrees 39 minutes 00 seconds East 104.24 feet; thence South 73 degrees 09 minutes 00 seconds East 51.59 feet; thence North 16 degrees 51 minutes 00 seconds East 591.56 feet to the south right-of-way line of said Briarwood Circle Drive; thence South 50 degrees 39 minutes 00 seconds East 148.83 feet along the south line of said Briarwood Circle Drive; thence South 16 degrees 51 minutes 00 seconds West 554.61 feet; thence North 73 degrees 09 minutes 00 seconds West 189.09 feet; thence 122.68 feet along the arc of a 156.20 foot radius curve to the right, having a chord bearing North 30 degrees 39 minutes 00 seconds West 119.55 feet; thence 122.68 feet along the arc of a 156.20 foot radius curve to the left, having a chord bearing North 50 degrees 39 minutes 00 seconds West 119.55 feet; thence South 16 degrees 51 minutes 00 seconds West 564.00 feet; thence 55.70 feet along the arc of a 212.77 foot radius curve to the right, having a chord bearing South 73 degrees 09 minutes 00 seconds East 55.54 feet; thence 55.70 feet along the arc of a 212.77 foot radius curve to the left, having a chord bearing South 80 degrees 39 minutes 00 seconds East 55.54 feet; thence South 73 degrees 09 minutes 00 seconds West 55.54 feet; thence South 06 degrees 35 minutes 00 seconds East 182.79 feet to a point on the north right-of-way line of said Briarwood Circle Drive; thence South 53 degrees 13 minutes 00 seconds West 42.87 feet along the north line of said Briarwood Circle Drive; thence 783.86 feet along the arc of a 837.38 foot radius curve to the right, having a chord bearing South 80 degrees 01 minutes 59 seconds West 755.55 feet along the north line of said Briarwood Circle Drive; thence North 73 degrees 09 minutes 00 seconds West 50.78 feet along the north line of said Briarwood Circle Drive; thence North 16 degrees 52 minutes 00 seconds East 529.69 feet; thence North 73 degrees 09 minutes 00 seconds West 11.69 feet; thence South 61 degrees 49 minutes 50 seconds West 143.12 feet; thence North 73 degrees 10 minutes 10 seconds West 394.24 feet; thence North 28 degrees 10 minutes 10 seconds West 143.12 feet; thence North 73 degrees 10 minutes 10 seconds West 11.53 feet; thence South 16 degrees 52 minutes 00 seconds West 529.48 feet to a point on the north right-of-way line of said Briarwood Circle Drive; thence North 73 degrees 09 minutes 00 seconds West 101.35 feet along the north line of said Briarwood Circle Drive; thence 227.97 feet along the arc of a 144.42 foot radius curve to the right, having a chord bearing North 66 degrees 37 minutes 40 seconds West 227.26 feet along the north line of said Briarwood Circle Drive; thence 394.10 feet along the arc of a 399.25 foot radius curve to the right, having a chord bearing North 51 degrees 49 minutes 35 seconds West 378.29 feet along the north line of said Briarwood Circle Drive; thence South 73 degrees 09 minutes 00 seconds East 65.25 feet; thence North 16 degrees 51 minutes 00 seconds East 241.63 feet; thence South 73 degrees 09 minutes 00 seconds East 487.50 feet; thence North 16 degrees 51 minutes 00 seconds East 563.99 feet to the POINT OF BEGINNING.