

INVITATION TO BID
FOR
BLUFFS PARK ENTRANCE IMPROVEMENTS

ITB- 4243



Due: Thursday, July 12, 2012 by 10:00 a.m.

Issuing Office:
CITY OF ANN ARBOR
Procurement Unit
301 E. Huron Street
Ann Arbor, Michigan 48104

TABLE OF CONTENTS

<u>Section</u>	<u>Pages</u>
Table of Contents	TC-1
Advertisement	AD-1
Notice of Pre-Bid Conference	NP-1
Instructions to Bidders.....	IB-1 to 6
Invitation to Bid.....	P1 to 3
Bid Forms	BF-1 to 5
Sample Contract	C-1 to 4
Bond Forms	B-1 to 2
General Conditions.....	GC-1 to 19
Standard Specifications	SS-2
Detailed Specifications.....	DS-1 to 28
Appendix A – Fair Employment Practice	1-2
Appendix B – Living Wage.....	3-4
Appendix C – Contract Compliance	5-7
Appendix D – CUB Notice	8
Appendix D - Plan Sheets	9-13

ADVERTISEMENT FOR
BLUFFS PARK ENTRANCE IMPROVEMENTS
CITY OF ANN ARBOR, MICHIGAN

ITB NO. 4243

Sealed Bids that include an original bid document and one additional proposal section copy will be received by the **Procurement Office, Finance Services, located on the 5th floor of the Guy Larcom Municipal Building, Ann Arbor, Michigan on or before Thursday, July 12, 2012 by 10:00 a.m.** local time for renovations to Bluffs Park and all associated work as specified and detailed. Bids will be publicly opened and read aloud at this time. Prospective submitters are responsible for timely receipt of their proposal. Late proposals will not be considered.

Work to be done includes sawcutting and removal of existing asphalt parking lot and removal of miscellaneous debris on site, and tree stump removal, grading, landscaping, limestone path installation, wood fence installation, and all other associated work.

Bid documents entirely downloadable on the Michigan Governmental Trade/BidNet (MITN) website at www.mitn.info and on the Purchasing page of the City of Ann Arbor's website at <http://www.a2gov.org/government/financeadminservices/procurement/Pages/OpenBidsandProposals.aspx> on or after or after Tuesday, June 25, 2012. The City will not be distributing paper copies of the plan or specifications.

Each proposal shall be accompanied by a certified check, or Bid Bond by a recognized surety, in the amount of 5% of the total of the bid price. A proposal, once submitted, becomes the property of the City. In the sole discretion of the City, the City reserves the right to allow a bidder to reclaim submitted documents provided the documents are requested and retrieved no later than 48 hours prior to the scheduled bid opening.

The successful Bidder will be required to furnish satisfactory performance and labor and material bonds in the amount of 100% of the bid price and satisfactory insurance coverage.

Precondition for entering into a contract with the City of Ann Arbor is compliance with Chapter 112 of Title IX of the Code of the City of Ann Arbor. The successful Bidder may also be required to comply with Chapter 23 of Title I of the Code of the City of Ann Arbor. The successful Bidders may also be required to comply with provisions of the Ann Arbor City Council Resolution R-12-246, and that it understands and agrees that any labor used on this Bid to be awarded by the City shall be governed by the current collective bargaining agreement of the appropriate Local Unions of the Washtenaw County Skilled Building Trades Council (SBTC).

After the time of opening, no Bid may be withdrawn for a period of 45 days. The City reserves the right to accept any Bid, to reject any or all Bids, to waive irregularities and/or informalities in any Bid, and to make the award in any manner the City believes to be in its best interest.

Any further information on bid documents may be obtained from the Procurement Office, (734) 794-6576.

CITY OF ANN ARBOR
PROCUREMENT UNIT

NOTICE OF PRE-BID CONFERENCE

A pre-bid meeting will be held at Bluffs Park (located on Sunset Road – see location map) on **Friday, July 6, 2012 at 10 a.m.**

Questions may be emailed to Amy Kuras at akuras@a2gov.org. If any questions arise whose answers constitute modifications to the bid documents, an addendum will be issued. Attendance at this meeting is highly recommended.

INSTRUCTIONS TO BIDDERS

General

Work to be done under this Contract is generally described through the detailed specifications and must be completed fully in accordance with the contract documents. All work to be done under this Contract is located in or near the City of Ann Arbor.

The City shall make available to all prospective Bidders, prior to receipt of the Bids, access to the area in which the work is to be performed. Advance notice should be given to the Administering Service Area/Unit in cases where access to the site must be arranged by the City.

Any Bid which does not conform fully with these instructions may be rejected.

Preparation of Bids

Bids should be prepared providing a straight-forward, concise description of the Bidder's ability to meet the requirements of the ITB. Bids shall be written in ink or typewritten. No erasures are permitted. Mistakes may be crossed out and corrected and must be initialed in ink by the person signing the Bid.

Bids must be submitted on Page Number BF 4-8 and on the "Bid Forms" provided with each blank properly filled in. If forms are not fully completed it may disqualify the bid.

Each person signing the Bid certifies that he/she is the person in the Bidder's firm/organization responsible for the decision as to the fees being offered in the Bid and has not and will not participated in any action contrary to the terms of this provision.

Questions or Clarification on ITB Specifications

All questions regarding this ITB shall be submitted via email. Emailed questions and inquires will be accepted from any and all prospective Bidders in accordance with the terms and conditions of the ITB.

All questions shall be due on or before Tuesday, July 10, 2012 by 10:00 a.m. and should be addressed as follows:

Specification/Scope of Work questions emailed to akuras@a2gov.org

Bid Process and HR Compliance questions emailed to newton@a2gov.org.

Addenda

If it becomes necessary to revise any part of the ITB, notice of the Addendum will be posted to Michigan Inter-governmental Trade Network (MITN) www.mitn.info City of Ann Arbor web site www.A2gov.org for all parties to download.

Each Bidder must in its Bid, to avoid any miscommunications, acknowledge all addenda which it has received, but the failure of a Bidder to receive, or acknowledge receipt of; any addenda shall not relieve the Bidder of the responsibility for complying with the terms thereof.

The City will not be bound by oral responses to inquiries or written responses other than written addenda.

Wage Requirements

For any City new construction project where the value of the contract is over \$25,000, Contractor further agrees to execute for itself, and to require as a condition of employment the execution by any and all subcontractors, a project labor agreement as provided by the Washtenaw County Skilled Building Trades Council Construction Unity Board (“CUB Agreement”). Failure to comply with this Article shall be deemed a material breach of the contract and grounds for termination.

Bid Submission

All Bids are due and must be delivered to the City of Ann Arbor Procurement Unit on or before (date) by (time). Bids submitted via oral, telephonic, telegraphic, electronic mail or facsimile **will not** be considered or accepted.

Each Bidder must submit one (1) original Bid and one (1) Bid copy in a sealed envelope clearly marked: **ITB 4243 – Bluffs Park Entry Improvements. Bids must be addressed and delivered to:**

City of Ann Arbor
Procurement Unit, 5th Floor
301 East Huron Street
P.O. Box 8647
Ann Arbor, MI 48107

All Bids received on or before the Due Date will be publicly opened and recorded immediately. No immediate decisions are rendered.

Bids should be date/time stamped/signed at the address above in order to be considered. Normal business hours are 8:00 a.m. to 4:00 p.m. Monday through Friday. The City will not be liable to any Bidder for any unforeseen circumstances, delivery or postal delays. Postmarking to the Due Date will not substitute for receipt of the Bid. Each Bidder is responsible for submission of their Bid.

Additional time will not be granted to a single Bidder; however, additional time may be granted to all Bidders when the City determines that circumstances warrant it.

Award

The City intends to award a Contract(s) to the lowest responsible Bidder(s). On multi-divisional contracts, separate divisions may be awarded to separate Bidders. The City may also utilize discounts offered in the Bid Forms, if any, to determine the lowest responsible Bidder on each division, and award multiple divisions to a single Bidder, so that the lowest total cost is achieved for the City. For unit price bids, the contract will be awarded based upon the lump sum and unit prices stated by the bidder for the work items specified in the bid documents, with consideration given to any alternates selected by the City. If the City determines that the unit price for any item is materially different for the work item bid than either other bidders or the general market, the City, in its sole discretion, in addition to any other right it may have, may reject the bid as not responsible or

non-conforming.

The acceptability of major subcontractors will be considered in determining if a Bidder is responsible. In comparing Bids, the City will give consideration to alternate Bids for items listed in the forms, or other alternates which the Bidder may wish to submit, but preference will be given to Base Bid Bids.

The City reserves the right to accept any Bid, to reject any or all Bids, to waive irregularities and/or informalities in any Bid, and to make the award in any manner the City believes to be in its best interest.

Official Documents

The City of Ann Arbor shall accept no changes to the bid documents made by the Bidder unless those changes are set forth in the "Alternate" section of Bid form.

The City of Ann Arbor officially distributes bid documents from the Purchasing Unit or through the Michigan Intergovernmental Trade Network (MITN). Copies of the bid documents obtained from any other source are not considered Official copies. Only those Bidders who obtain bid documents from MITN system are guaranteed access to receive addendum information if issued. If you obtained City of Ann Arbor Bid documents from other sources, it is recommended that you register on www.MITN.info and obtain an official Bid.

Bid Security

Each bid must be accompanied by a certified check, or Bid Bond by a surety licensed and authorized to do business within the State of Michigan, in the amount of 5% of the total of the bid price.

Withdrawal of Bids

After the time of opening, no Bid may be withdrawn for the period of days specified in the Advertisement.

Contract Time

Time is of the essence in the performance of the work under this Contract. The available time for work under this Contract is indicated on page C-1, Article III of the Contract. If these time requirements cannot be met, the Bidder must stipulate on Bid Form Section 3 - Time Alternate its schedule for performance of the work. Consideration will be given to time in evaluating bids.

Liquidated Damages

A liquidated damages clause, as given on page C-2, Article III of the Contract, provides that the Contractor shall pay the City as liquidated damages, and not as a penalty, a sum certain per day for each and every day that the Contractor may be in default of completion of the specified work, within the time(s) stated in the Contract, or written extensions.

Liquidated damages clauses, as given in the General Conditions, provide further that the City shall be entitled to impose and recover liquidated damages for breach of the obligations under Chapter

112 of the City Code.

The liquidated damages are for the non-quantifiable aspects of any of the previously identified events and do not cover actual damages that can be shown or quantified nor are they intended to preclude recovery of actual damages in addition to the recovery of liquidated damages.

Major Subcontractors

The Bidder shall identify each major subcontractor it expects to engage for this Contract if the work to be subcontracted is 15% or more of the bid sum or over \$50,000, whichever is less. The Bidder also shall identify the work to be subcontracted to each major subcontractor.

Debarment

Submission of a Bid in response to this ITB is certification that the Bidder is not currently debarred, suspended, proposed for debarment, and declared ineligible or voluntarily excluded from participation in this transaction by any State or Federal departments or agency. Submission is also agreement that the City will be notified of any changes in this status.

Disclosures

All information in a submitter's bid is subjected to disclosure under the provisions of Public Act No. 442 of 1976 know as the "Freedom of Information Act". This act also provides for the complete disclosure of contracts and attachments thereto except where specifically exempted under the Freedom of Information Act.

Human Rights Information

Section 5, beginning at page GC-3, outlines the requirements for fair employment practices under City of Ann Arbor Contracts. To establish compliance with this Ordinance, the Bidder must complete and return with its bid completed copies of the Contract Compliance Forms (copy attached) or an acceptable equivalent.

Wage Requirements

Section 4, beginning at page GC-1, outlines the requirements for payment of prevailing wages or of a "living wage" to employees providing service to the City under this contract.

In addition as stated in Section 4, City Council require all City invitations to bid on new construction contracts over \$25,000 include as a condition of award the requirement that all contractors and subcontractors execute CUB Agreements with the Washtenaw County Skilled Building Trade Council.

The successful bidder must comply with all applicable requirements and provide documentary proof of compliance when requested.

Liquidated Damages

A liquidated damages clause, as given on page C-2, Article III of the Contract, provides that the

Contractor shall pay the City as liquidated damages, and not as a penalty, a sum certain per day for each and every day that the Contractor may be in default of completion of the specified work, within the time(s) stated in the Contract, or written extensions.

Liquidated damages clauses, as given in the General Conditions, provide further that the City shall be entitled to impose and recover liquidated damages for breach of the obligations under Chapter 112 of the City Code.

The liquidated damages are for the non-quantifiable aspects of any of the previously identified events and do not cover actual damages that can be shown or quantified nor are they intended to preclude recovery of actual damages in addition to the recovery of liquidated damages.

Bid Protest

All Bid protests must be in writing and filed with the Purchasing Agent within five (5) business days of the award action. The vendor must clearly state the reasons for the protest. If a vendor contacts a City Service Area/Unit and indicates a desire to protest an award, the Service Area/Unit shall refer the vendor to the Purchasing Agent. The Purchasing Agent will provide the vendor with the appropriate instructions for filing the protest. The protest shall be reviewed by the City Administrator or designee who's decision shall be final.

Type Of Contract

A sample of the standard Contract is included in the bid documents. Those who wish to submit a Bid to the City are required to carefully review the Standard Contract. **The City will not entertain changes to the standard Contract.**

Reservation of Rights.

The City of Ann Arbor reserves the right to accept any bid or alternative bid proposed in whole or in part, to reject any or all bids or alternatives bids in whole or in part and to waive irregularity and/or informalities in any bid and to make the award in any manner deemed in the best interest of the City

INVITATION TO BID

City of Ann Arbor
Guy C. Larcom Municipal Building
Ann Arbor, Michigan 48107

Ladies and Gentlemen:

The undersigned, as Bidder, declares that this Bid is made in good faith, without fraud or collusion with any person or persons bidding on the same Contract; that this Bidder has carefully read and examined the bid documents, including Advertisement, Human Rights Division Contract Compliance Forms, Notice of Pre-Bid Conference, Instructions to Bidders, Proposal, Bid Forms, Contract, Bond Forms, General Conditions, Standard Specifications, Detailed Specifications, all Addenda, and the Plans and understands them. The Bidder declares that it conducted a full investigation at the site and of the work proposed and is fully informed as to the nature of the work and the conditions relating to the work's performance. The Bidder also declares that it has extensive experience in successfully completing projects similar to this one.

The Bidder acknowledges that it has not received or relied upon any representations or warrants of any nature whatsoever from the City of Ann Arbor, its agents or employees, and that this Bid is based solely upon the Bidder's own independent business judgment.

The undersigned proposes to perform all work shown on the plans or described in the bid documents, including any addenda issued, and to furnish all necessary machinery, tools, apparatus, and other means of construction to do all the work, furnish all the materials, and complete the work in strict accordance with all terms of the Contract of which this proposal is one part.

In accordance with these bid documents, and Addenda numbered 1, 2 + 3, the undersigned, as Bidder, proposes to perform at the sites in and/or around Ann Arbor, Michigan, all the work included herein for the amounts set forth in the Bid Forms.

The Bidder declares that it has become fully familiar with the liquidated damage clauses for completion times and for compliance with City Code Chapter 112, understands and agrees that the liquidated damages are for the non-quantifiable aspects of non-compliance and do not cover actual damages that may be shown and agrees that if awarded the Contract, all liquidated damage clauses form part of the Contract.

The Bidder declares that it has become fully familiar with the provisions of Chapter 14, Section 1:319 (Prevailing wages), Chapter 23 (Living Wage) of the Code of the City of Ann Arbor and CUB agreement of the Resolution R-12-246 of the Ann Arbor City Council and that bidders understand and agrees to comply, to the extent applicable to employees providing services to the City under this Contract, with the wage and reporting requirements stated in the City Code provisions cited. Bidder further agrees that the cited provisions of Chapter 14, Chapter 23 and CUB form a part of this Contract.

The Bidder encloses a certified check or Bid Bond in the amount of 5% of the total of the Bid Price. The Bidder agrees both to contract for the work and to furnish the necessary Bonds and insurance documentation within 10 days after being notified of the acceptance of the Bid.

If this Bid is accepted by the City and the Bidder fails to contract and furnish the required Bonds and insurance documentation within 10 days after being notified of the acceptance of this Bid, then the Bidder shall be considered to have abandoned the Contract and the certified check or Bid Bond accompanying this Proposal shall become due and payable to the City.

If the Bidder enters into the Contract in accordance with this Proposal, or if this Proposal is rejected, then the accompanying check or Bid Bond shall be returned to the Bidder.

In submitting this Bid, it is understood that the right is reserved by the City to accept any Bid, to reject any or all Bids, to waive irregularities and/or informalities in any Bid, and to make the award in any manner the City believes to be in its best interest.

SIGNED THIS 11th DAY OF July, 2012.

Margolis Companies

Bidder's/Contractor Name

9600 Cherry Hill

Ypsilanti, MI 48198

Official Address

734-482-0771

Telephone Number

Merrill Bumstead

Authorized Signature of Bidder

Merrill Bumstead

(Print Name of Signer Above)

LEGAL STATUS OF BIDDER

(The Bidder shall fill out the appropriate form and strike out the other two.)

Bidder declares that it is:

* A corporation organized and doing business under the laws of the state of Michigan, for whom Merrill Bunstead, bearing the office title of Project Manager whose signature is affixed to this proposal is authorized to execute contracts.

* A partnership, list all members and the street and mailing address of each:

Also identify the County and State where partnership papers are filed:

County of _____, State of _____

* An individual, whose signature with address, is affixed to this proposal: _____
(initial here)

BID FORMS
BLUFFS PARK ENTRANCE IMPROVEMENTS

<u>Item Description</u>	<u>Est. Quantity</u>	<u>Unit Price</u>	<u>Total Price</u>
1. Sawcut and remove asphalt surfacing and base to 8" depth. Remove miscellaneous debris, including tree stumps, concrete, brush piles and other construction debris, as identified in field	LS		\$ <u>5,500.⁰⁰</u>
2. Supply and install 4" clean fill	1944 SY	\$ <u>.75</u>	\$ <u>1,458.⁰⁰</u>
3. Supply and install 4" topsoil	1944 SY	\$ <u>3.⁰⁰</u>	\$ <u>5,832.⁰⁰</u>
4. Supply and install gravel path (21AA)	19 CY	\$ <u>100.⁰⁰</u>	\$ <u>1,900.⁰⁰</u>
5. Supply and install geotextile fabric under path	245 SY	\$ <u>3.⁰⁰</u>	\$ <u>735.⁰⁰</u>
6. Remove and replace existing curb	20 LF	\$ _____	\$ _____
7. Supply and install wood fence	430 LF	\$ <u>20.⁰⁰</u>	\$ <u>8,600.⁰⁰</u>
8. Supply and install Tulip tree, Liriodendron tulipifera, 1-3/4" b&b	1 EA	\$ <u>230.⁰⁰</u>	\$ <u>230.⁰⁰</u>
9. Supply and install Red-Osier Dogwood, Cornus stolonifera, 2 gallon container	8 EA	\$ <u>30.⁰⁰</u>	\$ <u>240.⁰⁰</u>
10. Supply and install Eastern Redbud, Cercis canadensis 1-3/4" b&b	2 EA	\$ <u>200.⁰⁰</u>	\$ <u>400.⁰⁰</u>
11. Supply and install White Pine Pinus strobus, 5-6' b&b	4 EA	\$ <u>150.⁰⁰</u>	\$ <u>600.⁰⁰</u>
12. Supply and install Swamp White Oak, Quercus bicolor 1-3/4" b&b	2 EA	\$ <u>260.⁰⁰</u>	\$ <u>520.⁰⁰</u>
13. Supply and install Bur Oak, Quercus macrocarpa 1-3/4" b&b	1 EA	\$ <u>260.⁰⁰</u>	\$ <u>260.⁰⁰</u>
14. Supply and install Witch Hazel, Hamamelis virginiana, 2 gallon container	3 EA	\$ <u>40.⁰⁰</u>	\$ <u>120.⁰⁰</u>
15. Supply and install River Birch, Betula nigra, 5-6' b&b	3 EA	\$ <u>200.⁰⁰</u>	\$ <u>600.⁰⁰</u>
16. Supply and install Flowering Dogwood, Cornus florida 1" b&b	1 EA	\$ <u>225.⁰⁰</u>	\$ <u>225.⁰⁰</u>
17. Supply and install Downy Serviceberry, Amelanchier arborea, 5-6' b&b	3 EA	\$ <u>151.⁰⁰</u>	\$ <u>453.⁰⁰</u>

18. Provide and install planting mix for wetland ^{upland prairie} Includes 3 year maintenance period - 0.31 AC	LS	\$ <u>1,500.⁰⁰</u>	\$ <u>1,500.⁰⁰</u>
19. Provide and install planting mix for upland prairie ^{wetland} Includes 3 year maintenance period - 0.05 AC	LS	\$ <u>8,500.⁰⁰</u>	\$ <u>8,500.⁰⁰</u>
20. Supply and install silt fence	550 LF	\$ <u>1.⁵⁰</u>	\$ <u>825.⁰⁰</u>
21. General Conditions: permits, mobilization, bonds, restoration	LS		\$ <u>2,500.⁰⁰</u>
TOTAL BID FOR BLUFFS PARK			\$ <u>49,998.⁰⁰</u>

Section 2 - Material and Equipment Alternates

The Base Bid proposal price shall include materials and equipment selected from the designated items and manufacturers listed in the bidding documents. This is done to establish uniformity in bidding and to establish standards of quality for the items named.

If the Contractor wishes to quote alternate items for consideration by the City, it may do so under this Section. A complete description of the item and the proposed price differential must be provided. Unless approved at the time of award, substitutions where items are specifically named will be considered only as a negotiated change in Contract Sum.

<u>Item Number</u>	<u>Description</u>	<u>Add/Deduct Amount</u>
--------------------	--------------------	--------------------------

If the Bidder does not suggest any material or equipment alternate, the Bidder **MUST** complete the following statement:

For the work outlined in this request for bid, the bidder does NOT propose any material or equipment alternate under the contract.

Meriel Barnsten

Signature of Authorized Representative of Bidder

BID FORM

Section 3 - Time Alternate

If the Bidder takes exception to the time stipulated in Article III of the Contract, Time of Completion, page C-1, it is requested to stipulate below its proposed time for performance of the work. Consideration will be given to time in evaluating bids.

90 Consecutive Calendar Days

If the Bidder does not suggest any time alternate, the Bidder **MUST** complete the following statement:

For the work outlined in this request for bid, the bidder does NOT propose any time alternate under the contract.

Signature of Authorized Representative of Bidder

BID FORM

Section 4 - Major Subcontractors

For purposes of this contract, a Subcontractor is anyone (other than the Contractor) who performs work (other than or in addition to the furnishing of materials, plans or equipment) at or about the construction site, directly or indirectly for or on behalf of the Contractor (and whether or not in privity of contract with the Contractor), but shall not include any individual who furnishes merely the individual's own personal labor or services.

For the work outlined in these documents the Bidder expects to engage the following major subcontractors to perform the work identified:

<u>Subcontractor (Name and Address)</u>	<u>Work</u>	<u>Amount</u>
Allied Fence	Fence	

If the Bidder does not expect to engage any major subcontractor, the Bidder **MUST** complete the following statement:

For the work outlined in this request for bid, the bidder does NOT expect to engage any major subcontractor to perform work under the contract.

Signature of Authorized Representative of Bidder

Addendum #1
Bluffs Park Entrance Improvements
ITB-4243

Issued July 3, 2012

Please note the following changes to this invitation to bid:

- 1) The CUB agreement requirement is **no longer** in affect. Please remove all CUB language and Appendix D, CUB Agreement from the specifications. In the final contract documents, all language referring to the CUB agreement will be removed.

- 2) In the Table of Contents it reads as Appendix D – Plan Sheets it should be replaced with Appendix E – Plan Sheets.

Please include this Addendum #1 with your bid on Thursday, July 12 by 10:00 a.m.

Name Merrill Bumstead

Company Margolis Companies

Address 9600 Cherry Hill Ypsilanti, MI

Phone 734-482-0771 Email mbumstead@margoliscompanies.com

Addendum #2
Bluffs Park Entrance Improvements
ITB-4243

Issued July 9, 2012

Please note the following changes to this invitation to bid:

1. The soil boring report is included with this addendum for reference.

Please include this Addendum #1 with your bid on Thursday, July 12 by 10:00 a.m.

Name Merrill Bumstead

Company Margolis Companies

Address 9600 Cherry Hill Ypsilanti, MI

Phone 734-482-0771 Email mbumstead@margoliscompanies.com

Addendum #3
Bluffs Park Entrance Improvements
ITB-4243

Issued July 10, 2012

Please note the following changes/clarifications to this invitation to bid:

1. The pre-bid meeting attendees are included with this addendum for reference.

2. Add Item 1A. All site grading LS \$ 9,000.⁰⁰
Please add this amount to the base bid total.

3. Remove item # 6 – Remove and replace curb. The contractor will be required to protect the existing curb. If the curb must be replaced because it is damaged during construction, an informative price shall be used to calculate cost:

Remove and replace existing curb LF \$ 100.⁰⁰

4. Line item 2 (install clean fill) will remain in the bid, however, the contractor may use CITY APPROVED existing material on site to provide base for the gravel walk, or to provide fill for the bottom of the slope. The fill material in the planting areas must not be contaminated with debris or any material over 1" (soil, sand, etc). However, all construction debris must be removed from the site, as specified in the bid documents. If reusing topsoil for fill, it must be screened. The City will receive a credit for the quantities not used from the bid item using the line item price quoted. The imported topsoil must be high quality, meeting the specifications in the bid documents.

5. Proposed gravel path must be 21AA Limestone. Crushed concrete is not an acceptable alternative.

Please include this Addendum #3 with your bid on Thursday, July 12 by 10:00 a.m.

Name Merrill Bumstead

Company Margolis Companies

Address 9600 Cherry Hill Ypsilanti, MI

Phone 734-482-0771 Email mbumstead@margoliscompanies.com

CONTRACT

THIS AGREEMENT is made on the 21st day of August, 2012, between the CITY OF ANN ARBOR, a Michigan Municipal Corporation, 301 E. Huron St., Ann Arbor, Michigan 48104 (“City”) and Margolis Companies, Inc. a Michigan Corporation located at 9600 Cherry Hill Road, Ypsilanti, Michigan, 48198.

Based upon the mutual promises below, the Contractor and the City agree as follows:

ARTICLE I - Scope of Work

The Contractor agrees to furnish all of the materials, equipment and labor necessary; and to abide by all the duties and responsibilities applicable to it for the project titled “BLUFFS PARK ENTRANCE IMPROVEMENTS” in accordance with the requirements and provisions of the following documents, including all written modifications incorporated into any of the documents, which are incorporated as part of this Contract:

Human Rights Division Contract	General Conditions
Compliance Forms	Standard Specifications
Living Wage Declaration of	Detailed Specifications
Compliance Forms	Plans
(if applicable)	Addenda
Bid Forms	
Proposal	
Contract and Exhibits	
Bonds	

ARTICLE II - Definitions

Administering Service area means **Parks and Recreation Services**

Supervising Professional means Sumedh Bahl or other persons acting under the authorization of the Director of the Administering Department.

Project means **Bluffs Park Entrance Improvements - Bid No. 4243**

ARTICLE III - Time of Completion

- (A) The work to be completed under this Contract shall begin immediately after the Contractor’s receipt of a fully executed Contract.
- (B) The entire work for this Contract shall be completed within 90 consecutive calendar days.
- (C) Failure to complete all the work within the time specified above, including any extension granted in writing by the Supervising Professional, shall obligate the

Contractor to pay the City, as liquidated damages and not as a penalty, an amount equal to **\$50.00** for each calendar day of delay in the completion of all the work. If any liquidated damages are unpaid by the Contractor, the City shall be entitled to deduct these unpaid liquidated damages from the monies due the Contractor.

As an independent requirement, where the Detailed Specifications identify certain portions of the work to be completed within a shorter period of time and the Contractor fails to complete each portion within the shorter period specified for each portion, including any extension granted in writing by the Project Supervisor, the City is entitled to deduct from the monies due the Contractor, as liquidated damages and not as a penalty, the amount identified in the Detailed Specifications for each portion of the work not timely completed for each calendar day of delay in completion of each portion of the work.

The liquidated damages are for the non-quantifiable aspects of any of the previously identified events and do not cover actual damages that can be shown or quantified nor are they intended to preclude recovery of actual damages in addition to the recovery of liquidated damages.

Liquidated damages under this section are in addition to any liquidated damages due under Section 5 of the General Conditions.

ARTICLE IV - The Contract Sum

- (A) The City shall pay to the Contractor for the performance of the Contract, the unit prices as given in the Bid Forms for the estimated total of:

<u>Forty nine thousand, nine hundred and ninety eight Dollars</u>	<u>\$49,998.00</u>
<small>Use words</small>	<small>Use numbers</small>

- (B) The amount paid shall be equitably adjusted to cover changes in the work ordered by the Supervising Professional but not required by the contract documents.

ARTICLE V - Assignment

This Contract may not be assigned or subcontracted without the written consent of the City.

ARTICLE VI - Choice of Law

This Contract shall be construed, governed, and enforced in accordance with the laws of the State of Michigan. By executing this agreement, the Contractor and the City agree to venue in a court of appropriate jurisdiction sitting within Washtenaw County for purposes of any action arising under this Contract.

Whenever possible, each provision of the contract will be interpreted in a manner as to be effective and valid under applicable law. The prohibition or invalidity, under applicable law, of any provision will not invalidate the remainder of the contract.

ARTICLE VII - Relationship of the Parties

The parties of the Contract agree that it is not a contract of employment but is a contract to accomplish a specific result. Contractor is an independent contractor performing services for the City. Nothing contained in this Contract shall be deemed to constitute any other relationship between the City and the Contractor.

Contractor certifies that it has no personal or financial interest in the project other than the compensation it is to receive under the Contract. Contractor certifies that it is not, and shall not become, overdue or in default to the City for any contract, debt, or any other obligation to the City including real or personal property taxes. City shall have the right to set off any such debt against compensation awarded for services under this agreement.

ARTICLE VIII - Notice

All notices given under this contract shall be in writing, and shall be by personal delivery or by certified mail with return receipt requested to the parties at their respective addresses as specified in the contract documents or other address the Contractor may specify in writing..

ARTICLE IX - Indemnification

To the fullest extent permitted by law, for any loss not covered by insurance under this contract, Contractor shall indemnify, defend and hold harmless the City, its officers, employees and agents harmless from all suits, claims, judgments and expenses including attorney's fees resulting or alleged to result, in whole or in part, from any act or omission, which is in any way connected or associated with this contract, by the Contractor or anyone acting on the Contractor's behalf under this contract. Contractor shall not be responsible to indemnify the City for losses or damages caused by or resulting from the City's sole negligence.

ARTICLE X - Entire Agreement

This Contract represents the entire understanding between the City and the Contractor and it supersedes all prior representations or agreements whether written or oral. Neither party has relied on any prior representations in entering into this Contract. This Contract may be altered, amended or modified only by written amendment signed by the City and the Contractor.

FOR CONTRACTOR
Margolis Companies, Inc.

By: _____
Merrill Bumstead

Its: Project Manager

FOR THE CITY OF ANN ARBOR

By _____
John Hieftje, Mayor

By _____
Jacqueline Beaudry, City Clerk

Approved as to substance

By _____
Steven D. Powers, City Administrator

By _____
Sumedh Bahl, Community Services
Administrator

Approved as to form and content

Stephen K. Postema, City Attorney

PERFORMANCE BOND

- (1) _____ of _____ (referred to as "Principal"), and _____, a corporation duly authorized to do business in the State of Michigan (referred to as "Surety"), are bound to the City of Ann Arbor, Michigan (referred to as "City"), for \$_____, the payment of which Principal and Surety bind themselves, their heirs, executors, administrators, successors and assigns, jointly and severally, by this bond.
- (2) The Principal has entered a written contract with the City dated _____, for: _____ and this bond is given for that contract in compliance with Act No. 213 of the Michigan Public Acts of 1963, as amended, being MCL 129.201 et seq.
- (3) Whenever the Principal is declared by the City to be in default under the contract, the Surety may promptly remedy the default or shall promptly:
- (a) complete the contract in accordance with its terms and conditions; or
 - (b) obtain a bid or bids for submission to the City for completing the contract in accordance with its terms and conditions, and upon determination by Surety of the lowest responsible bidder, arrange for a contract between such bidder and the City, and make available, as work progresses, sufficient funds to pay the cost of completion less the balance of the contract price; but not exceeding, including other costs and damages for which Surety may be liable hereunder, the amount set forth in paragraph 1.
- (4) Surety shall have no obligation to the City if the Principal fully and promptly performs under the contract.
- (5) Surety agrees that no change, extension of time, alteration or addition to the terms of the contract or to the work to be performed thereunder, or the specifications accompanying it shall in any way affect its obligations on this bond, and waives notice of any such change, extension of time, alteration or addition to the terms of the contract or to the work, or to the specifications.

SIGNED AND SEALED this _____ day of _____, 2012.

(Name of Surety Company)

(Name of Principal)

By

(Signature)

By

(Signature)

Its

(Title of Office)

Its

(Title of Office)

Name and address of agent:

Approved as to form:

Stephen K. Postema, City Attorney

LABOR AND MATERIAL BOND

- (1) _____ of _____, (referred to as "Principal"), and _____, a corporation duly authorized to do business in the State of Michigan, (referred to as "Surety"), are bound to the City of Ann Arbor, Michigan (referred to as "City"), for the use and benefit of claimants as defined in Act 213 of Michigan Public Acts of 1963, as amended, being MCL 129.201 *et seq.*, in the amount of \$ _____, for the payment of which Principal and Surety bind themselves, their heirs, executors, administrators, successors and assigns, jointly and severally, by this bond.
- (2) The Principal has entered a written contract with the City, dated _____, for: _____; and this bond is given for that contract in compliance with Act No. 213 of the Michigan Public Acts of 1963 as amended;
- (3) If the Principal fails to promptly and fully repay claimants for labor and material reasonably required under the contract, the Surety shall pay those claimants.
- (4) Surety's obligations shall not exceed the amount stated in paragraph 1, and Surety shall have no obligation if the Principal promptly and fully pays the claimants.

SIGNED AND SEALED this _____ day of _____, 2012.

(Name of Surety Company)	(Name of Principal)
By	By
(Signature)	(Signature)
Its	Its
(Title of Office)	(Title of Office)

Approved as to form:

Name and address of agent:

Stephen K. Postema, City Attorney

GENERAL CONDITIONS

Section 1 - Execution, Correlation and Intent of Documents

The contract documents shall be signed in 3 copies by the City and the Contractor.

The contract documents are complementary and what is called for by any one shall be binding. The intention of the documents is to include all labor and materials, equipment and transportation necessary for the proper execution of the work. Materials or work described in words which so applied have a well-known technical or trade meaning have the meaning of those recognized standards.

In case of a conflict among the contract documents listed below in any requirement(s), the requirement(s) of the document listed first shall prevail over any conflicting requirement(s) of a document listed later.

(1) Addenda in reverse chronological order; (2) Detailed Specifications; (3) Standard Specifications; (4) Drawings/Plans; (5) General Conditions; (6) Contract; (7) Bid Forms; (8) Bond Forms; (9) Proposal.

Section 2 - Order of Completion

The Contractor shall submit with each invoice, and at other times reasonably requested by the Supervising Professional, schedules showing the order in which the Contractor proposes to carry on the work. They shall include the dates at which the Contractor will start the several parts of the work, the estimated dates of completion of the several parts, and important milestones within the several parts.

Section 3 - Familiarity with Work

The Bidder or its representative shall make personal investigations of the site of the work and of existing structures and shall determine to its own satisfaction the conditions to be encountered, the nature of the ground, the difficulties involved, and all other factors affecting the work proposed under this Contract. The Bidder to whom this Contract is awarded will not be entitled to any additional compensation unless conditions are clearly different from those which could reasonably have been anticipated by a person making diligent and thorough investigation of the site.

The Bidder shall immediately notify the City upon discovery, and in every case prior to submitting its Bid, of every error or omission in the bidding documents that would be identified by a reasonably competent, diligent Bidder. In no case will a Bidder be allowed the benefit of extra compensation or time to complete the work under this Contract for extra expenses or time spent as a result of the error or omission.

Section 4 - Wage Requirements

Under this Contract, the Contractor shall conform to Chapter 14 of Title I of the Code of the City of Ann Arbor as amended; which in part states "...that all craftsmen, mechanics and laborers employed directly on the site in connection with said improvements, including said employees of subcontractors, shall receive the prevailing wage for the corresponding classes of craftsmen, mechanics and laborers, as determined by statistics for the Ann Arbor area compiled by the United States Department of Labor. At the request of the City, any contractor or subcontractor shall provide satisfactory proof of compliance with the contract provisions required by the Section."

For any City new construction project where the value of the contract is over \$25,000, Contractor further agrees to execute for itself, and to require as a condition of employment the execution by any and all subcontractors, a project labor agreement as provided by the Washtenaw County Skilled Building Trades Council Construction Unity Board ("CUB Agreement"). Failure to comply with this Article shall be deemed a material breach of the contract and grounds for termination.

Where the Contract and the Ann Arbor City Ordinance are silent as to definitions of terms required in determining contract compliance with regard to prevailing wages, the definitions provided in the Davis-Bacon Act as amended (40 U.S.C. 278-a to 276-a-7) for the terms shall be used.

1:814. Applicability.

- (1) This Chapter shall apply to any person that is a contractor/vendor or grantee as defined in Section 1:813 that employs or contracts with five (5) or more individuals; provided, however, that this Chapter shall not apply to a non-profit contractor/vendor or non-profit grantee unless it employs or contracts with ten (10) or more individuals.
- (2) This Chapter shall apply to any grant, contract, or subcontract or other form of financial assistance awarded to or entered into with a contractor/vendor or grantee after the effective date of this Chapter and to the extension or renewal after the effective date of this Chapter of any grant, contract, or subcontract or other form of financial assistance with a contractor/vendor or grantee.

1:815. Living Wages Required.

- (1) Every contractor/vendor or grantee, as defined in Section 1:813, shall pay its covered employees a living wage as established in this Section.
 - (a) For a covered employer that provides employee health care to its employees, the living wage shall be \$11.83 an hour, or the adjusted amount hereafter established under Section 1:815(3).
 - (b) For a covered employer that does not provide health care to its employees, the living wage shall be \$13.19 a hour, or the adjusted amount hereafter established under Section 1:815(3).
- (2) In order to qualify to pay the living wage rate for covered employers providing employee health care under subsection 1:815(1)(a), a covered employer shall furnish proof of said health care coverage and payment therefor to the City Administrator or his/her designee.

- (3) The amount of the living wage established in this Section shall be adjusted upward no later than April 30, 2012, and every year thereafter by a percentage equal to the percentage increase, if any, in the federal poverty guidelines as published by the United States Department of Health and Human Services for the year 2012. Subsequent annual adjustments shall be based upon the percentage increase, if any, in the United States Department of Health and Human Services poverty guidelines when comparing the prior calendar year's poverty guidelines to the present calendar year's guidelines. The applicable percentage amount will be converted to an amount in cents by multiplying the existing wage under Section 1.815(1)(b) by said percentage, rounding upward to the next cent, and adding this amount of cents to the existing living wage levels established under Sections 1:815(1)(a) and 1:815(1)(b). Prior to April 1 of each calendar year, the City will notify any covered employer of this adjustment by posting a written notice in a prominent place in City Hall, and, in the case of a covered employer that has provided an address of record to the City, by a written letter to each such covered employer.

Section 5 - Non-Discrimination

The Contractor agrees to comply with the nondiscrimination provisions of Chapter 112 of the Ann Arbor City Code and to take affirmative action to assure that applicants are employed and that employees are treated during employment in a manner which provides equal employment opportunity and tends to eliminate any inequality based upon race, national origin or sex. The Contractor agrees to comply with the provisions of Section 9:161 of Chapter 112 of the Ann Arbor City Code and in particular the following excerpts:

9:161 NONDISCRIMINATION BY CITY CONTRACTORS

- (1) All contractors proposing to do business with the City of Ann Arbor shall satisfy the nondiscrimination administrative policy adopted by the City Administrator in accordance with the guidelines of this section. All contractors shall receive approval from the Director prior to entering into a contract with the City, unless specifically exempted by administrative policy. All City contractors shall take affirmative action to insure that applicants are employed and that employees are treated during employment in a manner which provides equal employment opportunity and tends to eliminate inequality based upon race, national origin or sex.
- (2) Each prospective contractor shall submit to the City data showing current total employment by occupational category, sex and minority group. If, after verifying this data, the Director concludes that it indicates total minority and female employment commensurate with their availability within the contractor's labor recruitment area, i.e., the area from which the contractor can reasonably be expected to recruit, said contractor shall be accepted by the Director as having fulfilled affirmative action requirements for a period of one year at which time the Director shall conduct another review. Other contractors shall develop an affirmative action program in conjunction with the Director. Said program shall include specific goals and timetables for the hiring and promotion of minorities and females. Said goals shall reflect the availability of minorities and females within the contractor's labor recruitment area. In the case of construction contractors, the Director shall use for employment verification the labor recruitment area of the Ann Arbor-Ypsilanti standard metropolitan statistical area. Construction contractors determined to be in compliance shall be accepted by the Director as having fulfilled affirmative action requirements for a period of six (6) months at which time the Director shall conduct another review.

- (3) In hiring for construction projects, contractors shall make good faith efforts to employ local persons, so as to enhance the local economy.
- (4) All contracts shall include provisions through which the contractor agrees, in addition to any other applicable Federal or State labor laws:
 - (a) To set goals, in conference with the Human Resources Director, for each job category or division of the work force used in the completion of the City work;
 - (b) To provide periodic reports concerning the progress the contractor has made in meeting the affirmative action goals it has agreed to;
 - (c) To permit the Director access to all books, records and accounts pertaining to its employment practices for the purpose of determining compliance with the affirmative action requirements.
- (5) The Director shall monitor the compliance of each contractor with the nondiscrimination provisions of each contract. The Director shall develop procedures and regulations consistent with the administrative policy adopted by the City Administrator for notice and enforcement of non-compliance. Such procedures and regulations shall include a provision for the posting of contractors not in compliance.
- (6) All City contracts shall provide further that breach of the obligation not to discriminate shall be a material breach of the contract for which the City shall be entitled, at its option, to do any or all of the following:
 - (a) To cancel, terminate, or suspend the contract in whole or part and/or refuse to make any required periodic payments under the contract;
 - (b) Declare the contractor ineligible for the award of any future contracts with the City for a specified length of time;
 - (c) To recover liquidated damages of a specified sum, said sum to be that percentage of the labor expenditure for the time period involved which would have accrued to minority group members had the affirmative action not been breached;
 - (d) Impose for each day of non-compliance, liquidated damages of a specified sum, based upon the following schedule:

<u>Contract Amount</u>	<u>Assessed Damages Per Day of Non-Compliance</u>
\$ 10,000 - 24,999	\$ 25.00
25,000 - 99,999	50.00
100,000 - 199,999	100.00
200,000 - 499,999	150.00
500,000 - 1,499,999	200.00
1,500,000 - 2,999,999	250.00
3,000,000 - 4,999,999	300.00
5,000,000 - and above	500.00

(e) In addition the contractor shall be liable for any costs or expenses incurred by the City of Ann Arbor in obtaining from other sources the work and services to be rendered or performed or the goods or properties to be furnished or delivered to the City under this contract.

Section 6 - Materials, Appliances, Employees

Unless otherwise stipulated, the Contractor shall provide and pay for all materials, labor, water, tools, equipment, light, power, transportation, and other facilities necessary or used for the execution and completion of the work. Unless otherwise specified, all materials incorporated in the permanent work shall be new, and both workmanship and materials shall be of the highest quality. The Contractor shall, if required, furnish satisfactory evidence as to the kind and quality of materials.

The Contractor shall at all times enforce strict discipline and good order among its employees, and shall seek to avoid employing on the work any unfit person or anyone not skilled in the work assigned.

Adequate sanitary facilities shall be provided by the Contractor.

Section 7 - Qualifications for Employment

The Contractor shall employ competent laborers and mechanics for the work under this Contract. For work performed under this Contract, employment preference shall be given to qualified local residents.

Section 8 - Royalties and Patents

The Contractor shall pay all royalties and license fees. It shall defend all suits or claims for infringements of any patent rights and shall hold the City harmless from loss on account of infringement except that the City shall be responsible for all infringement loss when a particular process or the product of a particular manufacturer or manufacturers is specified, unless the City has notified the Contractor prior to the signing of the Contract that the particular process or product is patented or is believed to be patented.

Section 9 - Permits and Regulations

The Contractor must secure and pay for all permits, permit or plan review fees and licenses necessary for the prosecution of the work. These include but are not limited to City building permits, right-of-way permits, lane closure permits, right-of-way occupancy permits, and the like. The City shall secure and pay for easements shown on the plans unless otherwise specified.

The Contractor shall give all notices and comply with all laws, ordinances, rules and regulations bearing on the conduct of the work as drawn and specified. If the Contractor observes that the contract documents are at variance with those requirements, it shall promptly notify the Supervising Professional in writing, and any necessary changes shall be adjusted as provided in the Contract for changes in the work.

Section 10 - Protection of the Public and of Work and Property

The Contractor is responsible for the means, methods, sequences, techniques and procedures of construction and safety programs associated with the work contemplated by this contract. The Contractor, its agents or sub-contractors, shall comply with the "General Rules and Regulations for the Construction Industry" as published by the Construction Safety Commission of the State of Michigan and to all other local, State and National laws, ordinances, rules and regulations pertaining to safety of persons and property.

The Contractor shall take all necessary and reasonable precautions to protect the safety of the public. It shall continuously maintain adequate protection of all work from damage, and shall take all necessary and reasonable precautions to adequately protect all public and private property from injury or loss arising in connection with this Contract. It shall make good any damage, injury or loss to its work and to public and private property resulting from lack of reasonable protective precautions, except as may be due to errors in the contract documents, or caused by agents or employees of the City. The Contractor shall obtain and maintain sufficient insurance to cover damage to any City property at the site by any cause.

In an emergency affecting the safety of life, or the work, or of adjoining property, the Contractor is, without special instructions or authorization from the Supervising Professional, permitted to act at its discretion to prevent the threatened loss or injury. It shall also so act, without appeal, if authorized or instructed by the Supervising Professional.

Any compensation claimed by the Contractor for emergency work shall be determined by agreement or in accordance with the terms of Claims for Extra Cost - Section 15.

Section 11 - Inspection of Work

The City shall provide sufficient competent personnel for the inspection of the work.

The Supervising Professional shall at all times have access to the work whenever it is in preparation or progress, and the Contractor shall provide proper facilities for access and for inspection.

If the specifications, the Supervising Professional's instructions, laws, ordinances, or any public authority require any work to be specially tested or approved, the Contractor shall give the Supervising Professional timely notice of its readiness for inspection, and if the inspection is by an authority other than the Supervising Professional, of the date fixed for the inspection. Inspections by the Supervising Professional shall be made promptly, and where practicable at the source of supply. If any work should be covered up without approval or consent of the Supervising Professional, it must, if required by the Supervising Professional, be uncovered for examination and properly restored at the Contractor's expense.

Re-examination of any work may be ordered by the Supervising Professional, and, if so ordered, the work must be uncovered by the Contractor. If the work is found to be in accordance with the contract documents, the City shall pay the cost of re-examination and replacement. If the work is not in accordance with the contract documents, the Contractor shall pay the cost.

Section 12 - Superintendence

The Contractor shall keep on the work site, during its progress, a competent superintendent and any necessary assistants, all satisfactory to the Supervising Professional. The superintendent will be responsible to perform all on-site project management for the Contractor. The superintendent shall be experienced in the work required for this Contract. The superintendent shall represent the Contractor and all direction given to the superintendent shall be binding as if given to the Contractor. Important directions shall immediately be confirmed in writing to the Contractor. Other directions will be confirmed on written request. The Contractor shall give efficient superintendence to the work, using its best skill and attention.

Section 13 - Changes in the Work

The City may make changes to the quantities of work within the general scope of the Contract at any time by a written order and without notice to the sureties. If the changes add to or deduct from the extent of the work, the Contract Sum shall be adjusted accordingly. All the changes shall be executed under the conditions of the original Contract except that any claim for extension of time caused by the change shall be adjusted at the time of ordering the change.

In giving instructions, the Supervising Professional shall have authority to make minor changes in the work not involving extra cost and not inconsistent with the purposes of the work, but otherwise, except in an emergency endangering life or property, no extra work or change shall be made unless in pursuance of a written order by the Supervising Professional, and no claim for an addition to the Contract Sum shall be valid unless the additional work was ordered in writing.

The Contractor shall proceed with the work as changed and the value of the work shall be determined as provided in Claims for Extra Cost - Section 15.

Section 14 - Extension of Time

Extension of time stipulated in the Contract for completion of the work will be made if and as the Supervising Professional may deem proper under any of the following circumstances:

- (1) When work under an extra work order is added to the work under this Contract;
- (2) When the work is suspended as provided in Section 20;
- (3) When the work of the Contractor is delayed on account of conditions which could not have been foreseen, or which were beyond the control of the Contractor, and which were not the result of its fault or negligence;
- (4) Delays in the progress of the work caused by any act or neglect of the City or of its employees or by other Contractors employed by the City;
- (5) Delay due to an act of Government;
- (6) Delay by the Supervising Professional in the furnishing of plans and necessary information;
- (7) Other cause which in the opinion of the Supervising Professional entitles the Contractor to an extension of time.

The Contractor shall notify the Supervising Professional within 7 days of an occurrence or conditions which, in the Contractor's opinion, entitle it to an extension of time. The notice shall be in writing and submitted in ample time to permit full investigation and evaluation of the Contractor's claim. The Supervising Professional shall acknowledge receipt of the Contractor's notice within 7 days of its receipt. Failure to timely provide the written notice shall constitute a waiver by the Contractor of any claim.

In situations where an extension of time in contract completion is appropriate under this or any other section of the contract, the Contractor understands and agrees that the only available adjustment for events that cause any delays in contract completion shall be extension of the required time for contract completion and that there shall be no adjustments in the money due the Contractor on account of the delay.

Section 15 - Claims for Extra Cost

If the Contractor claims that any instructions by drawings or other media issued after the date of the Contract involved extra cost under this Contract, it shall give the Supervising Professional written notice within 7 days after the receipt of the instructions, and in any event before proceeding to execute the work, except in emergency endangering life or property. The procedure shall then be as provided for Changes in the Work-Section 13. No claim shall be valid unless so made.

If the Supervising Professional orders, in writing, the performance of any work not covered by the contract documents, and for which no item of work is provided in the Contract, and for which no unit price or lump sum basis can be agreed upon, then the extra work shall be done on a Cost-Plus-Percentage basis of payment as follows:

- (1) The Contractor shall be reimbursed for all reasonable costs incurred in doing the work, and shall receive an additional payment of 15% of all the reasonable costs to cover both its indirect overhead costs and profit;
- (2) The term "Cost" shall cover all payroll charges for employees and supervision required under the specific order, together with all worker's compensation, Social Security, pension and retirement allowances and social insurance, or other regular payroll charges on same; the cost of all material and supplies required of either temporary or permanent character; rental of all power-driven equipment at agreed upon rates, together with cost of fuel and supply charges for the equipment; and any costs incurred by the Contractor as a direct result of executing the order, if approved by the Supervising Professional;
- (3) If the extra is performed under subcontract, the subcontractor shall be allowed to compute its charges as described above. The Contractor shall be permitted to add an additional charge of 5% percent to that of the subcontractor for the Contractor's supervision and contractual responsibility;
- (4) The quantities and items of work done each day shall be submitted to the Supervising Professional in a satisfactory form on the succeeding day, and shall be approved by the Supervising Professional and the Contractor or adjusted at once;
- (5) Payments of all charges for work under this Section in any one month shall be made along with normal progress payments. Retainage shall be in accordance with Progress Payments-Section 16.

No additional compensation will be provided for additional equipment, materials, personnel, overtime or special charges required to perform the work within the time requirements of the Contract.

When extra work is required and no suitable price for machinery and equipment can be determined in accordance with this Section, the hourly rate paid shall be 1/40 of the basic weekly rate listed in the Rental Rate Blue Book published by Dataquest Incorporated and applicable to the time period the equipment was first used for the extra work. The hourly rate will be deemed to include all costs of operation such as bucket or blade, fuel, maintenance, "regional factors", insurance, taxes, and the like, but not the costs of the operator.

Section 16 - Progress Payments

The Contractor shall submit each month, or at longer intervals, if it so desires, an invoice covering work performed for which it believes payment, under the Contract terms, is due. The submission shall be to the City's Finance Department - Accounting Division. The Supervising Professional will, within 10 days following submission of the invoice, prepare a certificate for payment for the work in an amount to be determined by the Supervising Professional as fairly representing the acceptable work performed during the period covered by the Contractor's invoice. To insure the proper performance of this Contract, the City will retain a percentage of the estimate in accordance with Act 524, Public Acts of 1980. The City will then, following the receipt of the Supervising Professional's Certificate, make payment to the Contractor as soon as feasible, which is anticipated will be within 15 days.

An allowance may be made in progress payments if substantial quantities of permanent material have been delivered to the site but not incorporated in the completed work if the Contractor, in the opinion of the Supervising Professional, is diligently pursuing the work under this Contract. Such materials shall be properly stored and adequately protected. Allowance in the estimate shall be at the invoice price value of the items. Notwithstanding any payment of any allowance, all risk of loss due to vandalism or any damages to the stored materials remains with the Contractor.

In the case of Contracts which include only the Furnishing and Delivering of Equipment, the payments shall be; 60% of the Contract Sum upon the delivery of all equipment to be furnished, or in the case of delivery of a usable portion of the equipment in advance of the total equipment delivery, 60% of the estimated value of the portion of the equipment may be paid upon its delivery in advance of the time of the remainder of the equipment to be furnished; 30% of the Contract Sum upon completion of erection of all equipment furnished, but not later than 60 days after the date of delivery of all of the equipment to be furnished; and payment of the final 10% on final completion of erection, testing and acceptance of all the equipment to be furnished; but not later than 180 days after the date of delivery of all of the equipment to be furnished, unless testing has been completed and shows the equipment to be unacceptable.

With each invoice for periodic payment, the Contractor shall enclose a Contractor's Declaration - Section 43, and an updated project schedule per Order of Completion - Section 2.

Section 17 - Deductions for Uncorrected Work

If the Supervising Professional decides it is inexpedient to correct work that has been damaged or that was not done in accordance with the Contract, an equitable deduction from the Contract price

shall be made.

Section 18 - Correction of Work Before Final Payment

The Contractor shall promptly remove from the premises all materials condemned by the Supervising Professional as failing to meet Contract requirements, whether incorporated in the work or not, and the Contractor shall promptly replace and re-execute the work in accordance with the Contract and without expense to the City and shall bear the expense of making good all work of other contractors destroyed or damaged by the removal or replacement.

If the Contractor does not remove the condemned work and materials within 10 days after written notice, the City may remove them and, if the removed material has value, may store the material at the expense of the Contractor. If the Contractor does not pay the expense of the removal within 10 days thereafter, the City may, upon 10 days written notice, sell the removed materials at auction or private sale and shall pay to the Contractor the net proceeds, after deducting all costs and expenses that should have been borne by the Contractor. If the removed material has no value, the Contractor must pay the City the expenses for disposal within 10 days of invoice for the disposal costs.

The inspection or lack of inspection of any material or work pertaining to this Contract shall not relieve the Contractor of its obligation to fulfill this Contract and defective work shall be made good. Unsuitable materials may be rejected by the Supervising Professional notwithstanding that the work and materials have been previously overlooked by the Supervising Professional and accepted or estimated for payment or paid for. If the work or any part shall be found defective at any time before the final acceptance of the whole work, the Contractor shall forthwith make good the defect in a manner satisfactory to the Supervising Professional. The judgment and the decision of the Supervising Professional as to whether the materials supplied and the work done under this Contract comply with the requirements of the Contract shall be conclusive and final.

Section 19 - Acceptance and Final Payment

Upon receipt of written notice that the work is ready for final inspection and acceptance, the Supervising Professional will promptly make the inspection. When the Supervising Professional finds the work acceptable under the Contract and the Contract fully performed, the Supervising Professional will promptly sign and issue a final certificate stating that the work required by this Contract has been completed and is accepted by the City under the terms and conditions of the Contract. The entire balance found to be due the Contractor, including the retained percentage, shall be paid to the Contractor by the City within 30 days after the date of the final certificate.

Before issuance of final certificates, the Contractor shall file with the City:

- (1) The consent of the surety to payment of the final estimate;
- (2) The Contractor's Affidavit in the form required by Section 44.

In case the Affidavit or consent is not furnished, the City may retain out of any amount due the Contractor, sums sufficient to cover all lienable claims.

The making and acceptance of the final payment shall constitute a waiver of all claims by the City except those arising from:

- (1) unsettled liens;

- (2) faulty work appearing within 12 months after final payment;
- (3) hidden defects in meeting the requirements of the plans and specifications;
- (4) manufacturer's guarantees.

It shall also constitute a waiver of all claims by the Contractor, except those previously made and still unsettled.

Section 20 - Suspension of Work

The City may at any time suspend the work, or any part by giving 5 days notice to the Contractor in writing. The work shall be resumed by the Contractor within 10 days after the date fixed in the written notice from the City to the Contractor to do so. The City shall reimburse the Contractor for expense incurred by the Contractor in connection with the work under this Contract as a result of the suspension.

If the work, or any part, shall be stopped by the notice in writing, and if the City does not give notice in writing to the Contractor to resume work at a date within 90 days of the date fixed in the written notice to suspend, then the Contractor may abandon that portion of the work suspended and will be entitled to the estimates and payments for all work done on the portions abandoned, if any, plus 10% of the value of the work abandoned, to compensate for loss of overhead, plant expense, and anticipated profit.

Section 21 - Delays and The City's Right to Terminate Contract

If the Contractor refuses or fails to prosecute the work, or any separate part of it, with the diligence required to insure completion, ready for operation, within the allowable number of consecutive calendar days specified plus extensions, or fails to complete the work within the required time, the City may, by written notice to the Contractor, terminate its right to proceed with the work or any part of the work as to which there has been delay. After providing the notice the City may take over the work and prosecute it to completion, by contract or otherwise, and the Contractor and its sureties shall be liable to the City for any excess cost to the City. If the Contractor's right to proceed is terminated, the City may take possession of and utilize in completing the work, any materials, appliances and plant as may be on the site of the work and useful for completing the work. The right of the Contractor to proceed shall not be terminated or the Contractor charged with liquidated damages where an extension of time is granted under Extension of Time - Section 14.

If the Contractor is adjudged a bankrupt, or if it makes a general assignment for the benefit of creditors, or if a receiver is appointed on account of its insolvency, or if it persistently or repeatedly refuses or fails except in cases for which extension of time is provided, to supply enough properly skilled workers or proper materials, or if it fails to make prompt payments to subcontractors or for material or labor, or persistently disregards laws, ordinances or the instructions of the Supervising Professional, or otherwise is guilty of a substantial violation of any provision of the Contract, then the City, upon the certificate of the Supervising Professional that sufficient cause exists to justify such action, may, without prejudice to any other right or remedy and after giving the Contractor 3 days written notice, terminate this Contract. The City may then take possession of the premises and of all materials, tools and appliances thereon and without prejudice to any other remedy it may have, make good the deficiencies or finish the work by whatever method it may deem expedient, and deduct the cost from the payment due the Contractor. The Contractor shall not be entitled to receive any further payment until the work is finished. If the expense of finishing the work, including compensation for additional managerial and administrative services exceeds the unpaid balance of the Contract Sum, the Contractor and its surety are liable to the City for any excess cost incurred.

The expense incurred by the City, and the damage incurred through the Contractor's default, shall be certified by the Supervising Professional.

Section 22 - Contractor's Right to Terminate Contract

If the work should be stopped under an order of any court, or other public authority, for a period of 3 months, through no act or fault of the Contractor or of anyone employed by it, then the Contractor may, upon 7 days written notice to the City, terminate this Contract and recover from the City payment for all acceptable work executed plus reasonable profit.

Section 23 - City's Right to Do Work

If the Contractor should neglect to prosecute the work properly or fail to perform any provision of this Contract, the City, 3 days after giving written notice to the Contractor and its surety may, without prejudice to any other remedy the City may have, make good the deficiencies and may deduct the cost from the payment due to the Contractor.

Section 24 - Removal of Equipment and Supplies

In case of termination of this Contract before completion, from any or no cause, the Contractor, if notified to do so by the City, shall promptly remove any part or all of its equipment and supplies from the property of the City, failing which the City shall have the right to remove the equipment and supplies at the expense of the Contractor.

The removed equipment and supplies may be stored by the City and, if all costs of removal and storage are not paid by the Contractor within 10 days of invoicing, the City upon 10 days written notice may sell the equipment and supplies at auction or private sale, and shall pay the Contractor the net proceeds after deducting all costs and expenses that should have been borne by the Contractor and after deducting all amounts claimed due by any lien holder of the equipment or supplies.

Section 25 - Responsibility for Work and Warranties

The Contractor assumes full responsibility for any and all materials and equipment used in the construction of the work and may not make claims against the City for damages to materials and equipment from any cause except negligence or willful act of the City. Until its final acceptance, the Contractor shall be responsible for damage to or destruction of the project (except for any part covered by Partial Completion and Acceptance - Section 26). The Contractor shall make good all work damaged or destroyed before acceptance. All risk of loss remains with the Contractor until final acceptance of the work (Section 19) or partial acceptance (Section 26). The Contractor is advised to investigate obtaining its own builders risk insurance.

The Contractor shall guarantee the quality of the work for a period of one year. The Contractor shall also unconditionally guarantee the quality of all equipment and materials that are furnished and installed under the contract for a period of one year. At the end of one year after the Contractor's receipt of final payment, the complete work, including equipment and materials furnished and installed under the contract, shall be inspected by the Contractor and the Supervising Professional. Any defects shall be corrected by the Contractor at its expense as soon as practicable but in all cases within 60 days. Any defects that are identified prior to the end of one year shall also be inspected by the Contractor and the Supervising Professional and shall be corrected by the Contractor at its

expense as soon as practicable but in all cases within 60 days.

The Contractor shall assign all manufacturer or material supplier warranties to the City prior to final payment. The assignment shall not relieve the Contractor of its obligations under this paragraph to correct defects.

Section 26 - Partial Completion and Acceptance

If at any time prior to the issuance of the final certificate referred to in Acceptance and Final Payment - Section 19, any portion of the permanent construction has been satisfactorily completed, and if the Supervising Professional determines that portion of the permanent construction is not required for the operations of the Contractor but is needed by the City, the Supervising Professional shall issue to the Contractor a certificate of partial completion, and immediately the City may take over and use the portion of the permanent construction described in the certificate, and exclude the Contractor from that portion.

The issuance of a certificate of partial completion shall not constitute an extension of the Contractor's time to complete the portion of the permanent construction to which it relates if the Contractor has failed to complete it in accordance with the terms of this Contract. The issuance of the certificate shall not release the Contractor or its sureties from any obligations under this Contract including bonds.

If prior use increases the cost of, or delays the work, the Contractor shall be entitled to extra compensation, or extension of time, or both, as the Supervising Professional may determine.

Section 27 - Payments Withheld Prior to Final Acceptance of Work

The City may withhold or, on account of subsequently discovered evidence, nullify the whole or part of any certificate to the extent reasonably appropriate to protect the City from loss on account of:

- (1) Defective work not remedied;
- (2) Claims filed or reasonable evidence indicating probable filing of claims by other parties against the Contractor;
- (3) Failure of the Contractor to make payments properly to subcontractors or for material or labor;
- (4) Damage to another Contractor.

When the above grounds are removed or the Contractor provides a Surety Bond satisfactory to the City which will protect the City in the amount withheld, payment shall be made for amounts withheld under this section.

Section 28 - Contractor's Insurance

- A. The Contractor shall procure and maintain during the life of this Contract, including the guarantee period and during any warranty work, such insurance policies, including those set forth below, as will protect itself from all claims for bodily injuries, death or property damage which may arise under this Contract; whether the acts were made by the Contractor or by any subcontractor or anyone employed by them directly or indirectly. The following insurance policies are required:
1. Worker's Compensation Insurance in accordance with all applicable state and federal statutes. Further, Employers Liability Coverage shall be obtained in the following minimum amounts:

Bodily Injury by Accident - \$500,000 each accident
Bodily Injury by Disease - \$500,000 each employee
Bodily Injury by Disease - \$500,000 each policy limit
 2. Commercial General Liability Insurance equivalent to, as a minimum, Insurance Services Office form CG 00 01 07 98. The City of Ann Arbor shall be named as an additional insured. There shall be no added exclusions or limiting endorsements including, but not limited to: Products and Completed Operations, Explosion, Collapse and Underground coverage or Pollution. Further, the following minimum limits of liability are required:

\$1,000,000 Each occurrence as respect Bodily Injury Liability or Property Damage Liability, or both combined.

\$2,000,000 Per Job General Aggregate

\$1,000,000 Personal and Advertising Injury

\$2,000,000 Products and Completed Operations Aggregate
 3. Motor Vehicle Liability Insurance, including Michigan No-Fault Coverages, equivalent to, as a minimum, Insurance Services Office form CA 00 01 07 97. The City of Ann Arbor shall be named as an additional insured. There shall be no added exclusions or limiting endorsements. Coverage shall include all owned vehicles, all non-owned vehicles and all hired vehicles. Further, the limits of liability shall be \$1,000,000 for each occurrence as respects Bodily Injury Liability or Property Damage Liability, or both combined.
 4. Umbrella/Excess Liability Insurance shall be provided to apply excess of the Commercial General Liability, Employers Liability and the Motor Vehicle coverage enumerated above, for each occurrence and for aggregate in the amount of \$1,000,000.
- B. Insurance required under Section A.2 and A.3 of this Contract shall be considered primary as respects any other valid or collectible insurance that the City may possess, including any self-insured retentions the City may have; and any other insurance the City does possess shall be considered excess insurance only and shall not be required to contribute with this insurance. Further, the Contractor agrees to waive any right of recovery by its insurer against the City.

- C. In the case of all Contracts involving on-site work, the Contractor shall provide to the City before the commencement of any work under this Contract documentation demonstrating it has obtained the above mentioned policies. Documentation must provide and demonstrate an unconditional 30 day written notice of cancellation in favor of the City of Ann Arbor. Further, the documentation must explicitly state the following: (a) the policy number; name of insurance company; name and address of the agent or authorized representative; name and address of insured; project name; policy expiration date; and specific coverage amounts; (b) any deductibles or self-insured retentions which shall be approved by the City, in its sole discretion; (c) that the policy conforms to the requirements specified. An original certificate of insurance may be provided as an initial indication of the required insurance, provided that no later than 21 calendar days after commencement of any work the Contractor supplies a copy of the endorsements required on the policies. Upon request, the Contractor shall provide within 30 days a copy of the policy(ies) to the City. If any of the above coverages expire by their terms during the term of this Contract, the Contractor shall deliver proof of renewal and/or new policies to the Administering Department at least ten days prior to the expiration date.
- D. Any Insurance provider of Contractor shall be admitted and authorized to do business in the State of Michigan and shall carry and maintain a minimum rating assigned by A.M. Best & Company 's Key Rating Guide of 'A' Overall and a minimum Financial Size Category of 'V'. Insurance policies and certificates issued by non-admitted insurance companies are not acceptable unless approved in writing by the City.

Section 29 - Surety Bonds

Bonds will be required from the successful bidder as follows:

- (1) A Performance Bond to the City of Ann Arbor for the amount of the bid(s) accepted;
- (2) A Labor and Material Bond to the City of Ann Arbor for the amount of the bid(s) accepted.

Bonds shall be executed on forms supplied by the City in a manner and by a Surety Company satisfactory to the City Attorney.

Section 30 - Damage Claims

The Contractor shall be held responsible for all damages to property of the City or others, caused by or resulting from the negligence of the Contractor, its employees, or agents during the progress of or connected with the prosecution of the work, whether within the limits of the work or elsewhere. The Contractor must restore all property injured including sidewalks, curbing, sodding, pipes, conduit, sewers or other public or private property to not less than its original condition with new work.

Section 31 - Refusal to Obey Instructions

If the Contractor refuses to obey the instructions of the Supervising Professional, the Supervising Professional shall withdraw inspection from the work, and no payments will be made for work performed thereafter nor may work be performed thereafter until the Supervising Professional shall have again authorized the work to proceed.

Section 32 - Assignment

Neither party to the Contract shall assign the Contract without the written consent of the other. The Contractor may assign any monies due to it to a third party acceptable to the City.

Section 33 - Rights of Various Interests

Whenever work being done by the City's forces or by other contractors is contiguous to work covered by this Contract, the respective rights of the various interests involved shall be established by the Supervising Professional, to secure the completion of the various portions of the work in general harmony.

The Contractor is responsible to coordinate all aspects of the work, including coordination of, and with, utility companies and other contractors whose work impacts this project.

Section 34 - Subcontracts

The Contractor shall not award any work to any subcontractor without prior written approval of the City. The approval will not be given until the Contractor submits to the City a written statement concerning the proposed award to the subcontractor. The statement shall contain all information the City may require.

The Contractor shall be as fully responsible to the City for the acts and omissions of its subcontractors, and of persons either directly or indirectly employed by them, as it is for the acts and omissions of persons directly employed by it.

The Contractor shall cause appropriate provisions to be inserted in all subcontracts relative to the work to bind subcontractors to the Contractor by the terms of the General Conditions and all other contract documents applicable to the work of the subcontractors and to give the Contractor the same power to terminate any subcontract that the City may exercise over the Contractor under any provision of the contract documents.

Nothing contained in the contract documents shall create any contractual relation between any subcontractor and the City.

Section 35 - Supervising Professional's Status

The Supervising Professional has the right to inspect any or all work. The Supervising Professional has authority to stop the work whenever stoppage may be appropriate to insure the proper execution of the Contract. The Supervising Professional has the authority to reject all work and materials which do not conform to the Contract and to decide questions which arise in the execution of the work.

The Supervising Professional shall make all measurements and determinations of quantities. Those measurements and determinations are final and conclusive between the parties.

Section 36 - Supervising Professional's Decisions

The Supervising Professional shall, within a reasonable time after their presentation to the Supervising Professional, make decisions in writing on all claims of the City or the Contractor and on all other matters relating to the execution and progress of the work or the interpretation of the contract documents.

Section 37 - Storing Materials and Supplies

Materials and supplies may be stored at the site of the work at locations agreeable to the City unless specific exception is listed elsewhere in these documents. Ample way for foot traffic and drainage must be provided, and gutters must, at all times, be kept free from obstruction. Traffic on streets shall be interfered with as little as possible. The Contractor may not enter or occupy with agents, employees, tools, or material any private property without first obtaining written permission from its owner. A copy of the permission shall be furnished to the Supervising Professional.

Section 38 - Lands for Work

The Contractor shall provide, at its own expense and without liability to the City, any additional land and access that may be required for temporary construction facilities or for storage of materials.

Section 39 - Cleaning Up

The Contractor shall, as directed by the Supervising Professional, remove at its own expense from the City's property and from all public and private property all temporary structures, rubbish and waste materials resulting from its operations unless otherwise specifically approved, in writing, by the Supervising Professional.

Section 40 - Salvage

The Supervising Professional may designate for salvage any materials from existing structures or underground services. Materials so designated remain City property and shall be transported or stored at a location as the Supervising Professional may direct.

Section 41 - Night, Saturday or Sunday Work

No night or Sunday work (without prior written City approval) will be permitted except in the case of an emergency and then only to the extent absolutely necessary. The City may allow night work which, in the opinion of the Supervising Professional, can be satisfactorily performed at night. Night work is any work between 8:00 p.m. and 7:00 a.m. No Saturday work will be permitted unless the Contractor gives the Supervising Professional at least 48 hours but not more than 5 days notice of the Contractor's intention to work the upcoming Saturday.

Section 42 - Sales Taxes

Under State law the City is exempt from the assessment of State Sales Tax on its direct purchases. Contractors who acquire materials, equipment, supplies, etc. for incorporation in City projects are not likewise exempt. State Law shall prevail. The Bidder shall familiarize itself with the State Law and prepare its Bid accordingly. No extra payment will be allowed under this Contract for failure of the Contractor to make proper allowance in this bid for taxes it must pay.

Section 43

CONTRACTOR'S DECLARATION

I hereby declare that I have not, during the period _____, 201____, to
_____, 20____, performed any work, furnished any materials, sustained any loss, damage or
delay, or otherwise done anything in addition to the regular items (or executed change orders) set
forth in the Contract titled

_____,
for which I shall ask, demand, sue for, or claim compensation or extension of time from the City,
except as I hereby make claim for additional compensation or extension of time as set forth on the
attached itemized statement. I further declare that I have paid all payroll obligations related to this
Contract that have become due during the above period and that all invoices related to this Contract
received more than 30 days prior to this declaration have been paid in full except as listed below.

There is/is not (Contractor please circle one and strike one as appropriate) an itemized statement
attached regarding a request for additional compensation or extension of time.

Contractor Date

By
(Signature)

Its
(Title of Office)

Past due invoices, if any, are listed below.

Section 44

CONTRACTOR'S AFFIDAVIT

The undersigned Contractor, _____, represents that on _____20__, it was awarded a contract by the City of Ann Arbor, Michigan to _____ under the terms and conditions of a Contract titled _____.

The Contractor represents that all work has now been accomplished and the Contract is complete.

The Contractor warrants and certifies that all of its indebtedness arising by reason of the Contract has been fully paid or satisfactorily secured; and that all claims from subcontractors and others for labor and material used in accomplishing the project, as well as all other claims arising from the performance of the Contract, have been fully paid or satisfactorily settled. The Contractor agrees that, if any claim should hereafter arise, it shall assume responsibility for it immediately upon request to do so by the City of Ann Arbor.

The Contractor, for valuable consideration received, does further waive, release and relinquish any and all claims or right of lien which the Contractor now has or may acquire upon the subject premises for labor and material used in the project owned by the City of Ann Arbor.

This affidavit is freely and voluntarily given with full knowledge of the facts.

Contractor
By
(Signature)
Its
(Title of Office)

Subscribed and sworn to before me, on this _____ day of _____, 2012
_____, _____ County, Michigan

Notary Public
My commission expires on:

STANDARD SPECIFICATIONS

All work under this contract shall be performed in accordance with the Public Services Department Standard Specifications in effect at the date of availability of the contract documents stipulated in the Advertisement. All work under this Contract which is not included in these Standard Specifications, or which is performed using modifications to these Standard Specifications, shall be performed in accordance with the Detailed Specifications included in these contract documents.

The Standard Specifications are available for public viewing on the City of Ann Arbor Website: www.a2gov.org/government/publicservices/project_management/privatedev/Pages/Standardspecificationbook.aspx



Bluffs Park Location

park on Sunset, NOT in parking lot

City: Ann Arbor
Date: March, 2012

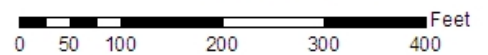

**DETAILED SPECIFICATIONS
FOR
GENERAL REQUIREMENTS**

GENERAL REQUIREMENTS

- A. INVESTIGATIONS - The Contractor shall have visited the site, consulted all applicable drawings and records of existing utilities in the Contract area and made all other necessary investigation of sub-surface conditions which might affect the work required by this Contract before submission of his/her bid. It shall be understood and agreed that the Contractor assumes all risks involved in performing the excavating work required by this Contract and that his/her bid shall include the cost of all investigations.
- B. SURVEY, MEASUREMENT AND LAYOUT - The Contractor will provide survey work necessary for grading and layout of the project. All layout and staking is subject to approval by the Parks and Recreation Services prior to proceeding with excavation and construction.
- C. MINOR CHANGES - It shall be understood and agreed that should minor changes or deviations from the finished grades shown on the drawings be required by the Landscape Architect, they shall be made by the Contractor at no additional cost therefore.
- D. PROTECTION - The Contractor shall erect and maintain fences, guardrails, and provide any other necessary safeguards to protect the public, the work and all property from any hazards that are an inherent part of the work under this Contract.

DETAILED SPECIFICATION FOR MACHINE GRADING

DESCRIPTION

This work shall consist of constructing earth grades by excavating, cutting, filling, trimming, and grading; furnishing and placing a 4-inch thick layer of topsoil; seeding and mulching; turf establishment and general restoration in accordance with the Detailed Specifications elsewhere herein; and maintaining the work in a finished condition until such time that it is accepted by the Supervising Professional. This work shall be done as shown on the Plans, as detailed in the Specifications, and as directed by the Supervising Professional, and in accordance with Section 205 of the 2003 edition of the MDOT Standard Specification for Construction, except as specified herein.

CONSTRUCTION METHOD

The Contractor shall construct earth grades as required to develop the typical and/or detailed cross-section(s) as shown on the Plans, as detailed in the Specifications, and as directed by the Supervising Professional. This shall include, but not be limited to, the excavation of bituminous pavement, soil, rocks of any size, stumps, logs and bricks; the removal and proper disposal off-site of surplus excavated material and material which is determined by the Supervising Professional to be unsuitable for re-use; the scarifying, plowing, disking, moving and shaping of earth: the trimming, grading, compaction and proof-rolling of the prepared subgrade; the importing, furnishing, placement and compaction of embankment and/or fill materials; the full depth saw-cutting of pavement at the removal limits; the grading of sideslopes; the furnishing and placing of a 4-inch thick layer of topsoil; seeding, turf establishment and general restoration in accordance with the Detailed Specifications elsewhere herein and the general items of the work as specified herein.

The Contractor shall remove, add to, re-shape, re-grade, and re-compact the existing court or pathway surface materials, and shall construct the court areas, parking lots, or pathways to the cross-section(s) as indicated on the Plans, as detailed in the Specifications, and as directed by the Supervising Professional. The Contractor shall use blade graders, maintainers, vibratory rollers, and/or other equipment as necessary, and as directed by the Supervising Professional, for this work. Use of each specific piece of equipment is subject to the approval of the Supervising Professional.

The Contractor shall remove other surface features located within the grading limits and not otherwise identified, as directed by the Supervising Professional.

The Contractor shall move excavated and/or imported materials longitudinally and/or transversely where necessary, and as directed by Supervising Professional.

The Contractor shall keep the work well graded and drained at all times.

The Contractor shall not use rubber-tired equipment on the subgrade, when its use causes or may cause, in the opinion of the Supervising Professional, damage to the subgrade. The Contractor shall conduct its operation(s), and provide all necessary equipment, to insure the satisfactory completion of the work without damaging the subgrade. This includes the transporting, stockpiling, rehandling, and movement of materials over additional distances, in lieu of driving on an unprotected, or partially unprotected, subgrade.

The Contractor is solely responsible for the maintenance and protection of the subgrade. Further, any damage to the subgrade which, in the opinion of the Supervising Professional, is caused as a result of the Contractor's

operation(s), or its subcontractors' or suppliers' operation(s), shall be repaired by the Contractor at the Contractor's expense. This includes any additional earthwork and/or maintenance materials as directed by the Supervising Professional, for the purposes of the Contractor's maintenance and protection of the subgrade. The Contractor shall not be entitled to any additional compensation for the implementation of these procedures.

The Contractor shall perform all rough and/or finish grading and compaction to the grades shown on the Plans, as detailed in the Specifications, and as directed by the Supervising Professional.

The Contractor shall proofroll all graded and compacted surfaces in the presence of the Supervising Professional. The Supervising Professional will monitor the proofrolling operation to locate deleterious and/or uncompacted materials, and will direct undercuts as necessary.

At various times throughout the work, the Supervising Professional may direct the Contractor to use smaller and/or lighter equipment, and to defer certain work tasks, in order to protect the grade and/or adjacent areas. The Contractor shall not be entitled to any additional compensation for the use of smaller equipment, lighter equipment, or work task deferral.

The Contractor shall continuously maintain all drive entrances located within the construction limits.

**DETAILED SPECIFICATION FOR
CLASS II SAND - C.I.P.
21AA LIMESTONE - C.I.P.**

DESCRIPTION

This work shall consist of constructing an aggregate subbase or base course on an existing aggregate surface, or on a prepared subgrade in accordance with Sections 301, 302 and 307 of the 2003 edition of the MDOT Standard Specifications for Construction, except as specified herein.

MATERIAL

The materials used for this work shall be MDOT 21AA, and Class II granular material meeting the requirements of the City of Ann Arbor Standard Specifications.

CONSTRUCTION METHOD

Sand or aggregate courses shall not be placed if, in the opinion of the Supervising Professional, there are any indications that they may become frozen before their specified densities are obtained.

Sand or aggregate courses shall not be placed on a frozen base, subbase or subgrade.

The Contractor shall not use rubber-tired equipment on the grade, when its use causes, or may cause, in the opinion of the Supervising Professional, damage to the grade. The Contractor shall conduct his/her operation(s), and provide all necessary equipment, to insure the satisfactory completion of the work without damaging the grade. This includes the transporting, stockpiling, rehandling, and movement of materials over additional distances, in lieu of driving on an unprotected, or partially unprotected, grade.

The Contractor is solely responsible for the maintenance and protection of the grade. Further, any damage to the grade which, in the opinion of the Supervising Professional, is caused as a result of the Contractor's operation(s), or his/her subcontractors' or suppliers' operation(s), shall be repaired by the Contractor at the Contractor's expense. This includes any additional earthwork and/or maintenance materials as directed by the Supervising Professional, for the purposes of the Contractor's maintenance and protection of the grade.

The Contractor shall shape the base, subbase and subgrade to the elevations, crowns, and grades as specified on the Plans and as directed by the Supervising Professional. This may include regrading the subbase to provide different crown grades than those existing prior to the construction.

The Contractor shall remove, add to, re-shape, re-grade, and re-compact the existing subbase materials, and shall construct the game court, parking lot, driveways, pathways, and tennis courts to the cross-section(s) as indicated on the Plans, as detailed in the Specifications, and as directed by the Supervising Professional. The Contractor shall use blade graders, **maintainers**, vibratory rollers, and/or other equipment as necessary, and as directed by the Supervising Professional, for this work. Use of each specific piece of equipment is subject to the approval of the Supervising Professional.

The Contractor shall maintain the base, subbase and subgrade in a smooth, well drained condition at all times.

Sand and aggregate courses shall be placed in uniform layers such that when compacted, they have the thicknesses shown on the Plans, or as directed by the Supervising Professional. The loose measure of any layer shall not be more than 9-inches nor less than 4-inches.

Sand subbase and aggregate base courses shall be compacted to not less than 98% of their respective maximum unit weights, as determined by the AASHTO T-180 test.

All granular materials shall be deposited from trucks or through a spreader in a manner that will minimize segregation of material.

Manholes, valve boxes, inlet structures and curbs shall be protected from damage. Manholes & inlet structures shall be continuously cleaned of construction debris and properly covered at all times during the construction. Upon completion of each days work, manholes, water valve boxes, inlets and catch basins shall be thoroughly cleaned of all extraneous material.

At various times throughout the work, the Supervising Professional may direct the Contractor to use smaller and/or lighter equipment, and to defer certain work tasks, in order to protect the grade and/or adjacent areas. The Contractor shall not be entitled to any additional compensation for the use of smaller equipment, lighter equipment, or work task deferral.

MEASUREMENT AND PAYMENT

Where granular materials are used as base, as subbase, or as fill for undercuts in Machine Grading areas, items of work "Aggregate Base Course 21AA -C.I.P." and "Sand Subbase Course CL II - C.I.P." shall be measured and paid accordingly.

Where granular materials are used as fill for undercuts at locations other than Machine Grading areas, items of work "22A Aggregate - C.I.P.", "CL II Sand - C.I.P." and "21AA Limestone - C.I.P." shall be measured and paid accordingly.

The unit prices for these items of work shall include all labor, material, and equipment costs to perform all the work specified in the Standard Specifications and as modified by this Detailed Specification.

Technical Specification for NATIVE SEEDING

PART 1 – GENERAL

1.01 DESCRIPTION

- A. This work shall consist of preparing the seedbed, seeding, and maintaining the seeded areas as indicated on the plans or as directed by the Engineer.
- B. All work shall be performed in accordance with Section 816 of the 2003 Michigan Department of Transportation Standard Specifications for Construction and the City of Ann Arbor Public Services Department Standard Specifications for Construction (Orange Book), and as specified herein. In the event that these specifications conflict, the more stringent requirements shall govern.
- C. An on-site meeting with the LANDSCAPE CONTRACTOR and the ENGINEER shall be scheduled by the ENGINEER prior to seeding.

1.02 SUBMITTALS

- A. Within thirty (30) days after award of the contract the CONTRACTOR shall provide seed sources and documentation of species availability to the ENGINEER.
- B. The CONTRACTOR shall provide seed certificates containing the following information to the OWNER for review and approval a minimum of one (1) month prior to the time of seeding:
 - 1. Botanical name, including cultivar and genotype, and common name.
 - 2. Net weight.
 - 3. Percentage of seed by weight.
 - 4. Purity of seed.
 - 5. Germination percentage.
 - 6. Amount of undesirable plant seeds present in mixture.
 - 7. Date of production.
 - 8. Date of packaging.
 - 9. Location of packaging.
 - 10. Name, address, phone number and contact name of supplier.
- C. The CONTRACTOR shall provide a small physical sample of the temporary erosion control blanket with the name, address, phone number and contact name of supplier, a minimum of one (1) month prior to the time of seeding.
- D. The CONTRACTOR shall not make substitutions if specified seed is not obtainable. Submit proof of non-availability to ENGINEER together with proposal for use of equivalent material. All substitutions for materials or execution shall be approved by the ENGINEER in writing a minimum of one (1) month prior to construction.
- E. The ENGINEER reserves the right to require a sample of substituted material(s) prior to approval for construction.

1.03 QUALITY ASSURANCE

- A. Installation of seed shall be carried out by LANDSCAPE CONTRACTORS and their employees who are thoroughly experienced and skilled in the work and who are completely familiar with the specified requirements and methods needed for proper performance of the work in this section. The LANDSCAPE CONTRACTOR shall have a minimum of five (5) years of documented experience in comparable work, particularly native wetland seed installation. The contractor must supply documentation of such experience with at least three successful projects completed in the last five years. This documentation shall include at

a minimum, the number of acres planted, year project was completed, along with the project name, contact person, phone number, and address.

B. The CONTRACTOR shall warrant all plant material to be true to botanical name.

C. All seed shall be inspected and approved by the ENGINEER prior to installation. The ENGINEER shall reserve the right to refuse any plant material that is unacceptable upon delivery to the site.

PART 2 – PRODUCTS

2.01 SEED

A. All materials shall meet the requirements of the 2003 Michigan Department of Transportation Standard Specifications for Construction and the City of Ann Arbor Public Services Department Standard Specifications for Construction (Orange Book), and as specified herein.

B. Suppliers shall belong to the “Michigan Native Plant Producers Association,” and seed shall be Michigan Genotype, with the exception of temporary grasses and Elymus species, if Michigan Genotype is unavailable.

C. The Contractor shall provide a fresh, clean, new crop seed along with a guaranteed statement of the composition of the mixture and the percentages of purity and germination of each variety. All seeds shall be packaged and kept dry and cool to ensure adequate protection against damage, and maintain dormancy while in transit, storage or during planting operations. Seed shall be less than one year old. Seed shall be stored as recommended by supplier. Seed exhibiting signs of extended periods of storage, excessive moisture, mold, decay, depredation or other physical damage will be unacceptable.

D. All seed shall be delivered to the site in sealed containers and labeled, in compliance with the Federal Seed Act and Michigan Seed Law (P.A. 329, 1965). Large and small seed shall be delivered in separate containers.

E. Seed shall be free from weeds and undesirable plant species according to industry standards. Seed shall contain no federal or state listed noxious or invasive weeds, as determined by a standard purity test.

G. No aggressive, threatened, endangered, or special concern species shall be in the seed mix.

2.02 TEMPORARY EROSION CONTROL BLANKET

A. The CONTRACTOR shall provide erosion control net material constructed of heavy, woven jute mesh with plain weave of unbleached single jute yarn having openings of ¾-inch or less, with a fabric weight of 20 ounces per square yard or more, having high tensile strength and durability.

B. Plastic poly-netting will not be allowed.

C. Fasteners for jute mesh shall be 11 gauge steel wire, formed into a “U” shaped staple 6 inches long.

2.03 TOPSOIL

A. Quantity: The CONTRACTOR shall be responsible for estimating the quantity of imported topsoil necessary to obtain the necessary depth of topsoil for planting. The approximate in-place quantity estimated on the plans is for information purposes only. The CONTRACTOR shall report any discrepancy between the estimate on the Plans to the ENGINEER.

B. Imported topsoil shall be friable sandy loam capable of supporting optimal plant growth and development. It shall be free of clay lumps, subsoil, invasive weeds and seeds, stones, sticks and other extraneous materials.

D. Analysis for existing and imported topsoil shall be done at the CONTRACTOR'S expense and shall be submitted to ENGINEER for approval prior to use. CONTRACTOR shall supply recommendations for starter fertilizer for both planting and seeding areas.

E. The structural topsoil analysis for the wetland mitigation area shall include the following and be within the listed parameters:

Clay content: 5-10%

pH range: 6.0-7.0

Organic matter content: 5-20%

F. The chemical soil analysis for the wetland mitigation area shall include the following and soils shall be adjusted with starter fertilizer based on the testing agencies recommendations:

Available Phosphorus

Exchangeable Potassium

Magnesium

Calcium

Cation Exchange Capacity

Percent Base Saturation of Cation Elements

Available Nitrogen

G. The structural topsoil analysis for other areas shall include the following and be within the listed parameters:

Clay content: 5-15%

pH range: 6.0-7.5

Organic matter content: 2-5%

H. The chemical soil analysis for other areas shall include the following and soils shall be adjusted with starter fertilizer based on the testing agencies recommendations:

Available Phosphorus

Exchangeable Potassium

Magnesium

Calcium

Cation Exchange Capacity

Percent Base Saturation of Cation Elements

Available Nitrogen

I. Testing and recommendations for starter fertilizer for wetland mitigation area and other area topsoil may be performed through A&L Great Lakes Laboratories, Inc., Fort Wayne Indiana 1.260.483.4759.

2.04 COMPOST

A. Compost shall be used only from City of Ann Arbor, available from WeCare Organics 1.734.477.0334, or approved substitution.

PART 3 – EXECUTION

3.01 GENERAL

A. Avoid soil compaction in seeding areas as much as possible. Equipment access and travel should be routed to limit repeat passes over the same area during all grading, topsoil application, and decompaction work. Equipment having low unit pressure ground contact should be utilized whenever possible. Prior to seeding, repair any ruts, rills or gullies greater than 2 inches in depth to create smooth continuous grades.

B. Damage to restored areas resulting from storms, including major storms, settlement, or erosion shall be repaired by the Contractor, at the Contractor's expense.

C. Temporary Erosion Control Blanket shall be installed by CONTRACTOR as shown on the plans and on

any disturbed area with a slope steeper than 4:1, including access routes, and other areas where the ENGINEER determines it to be necessary for seed establishment. Blanket shall be secured with specified fasteners.

3.02 SEED INSTALLATION

- A. The seeding shall be done from April 1 to June 15 or from September 15 to first frost. Optimal wetland seeding time is October 1 through first frost to allow repeat freeze-thaw cycles to incorporate the seed into the substrate and provide cold stratification to break seed dormancy. The seeding must be complete before June 15 or after September 15 of a given calendar year.
- B. Seeding shall not occur between June 15 and September 15 except with special approval by the Engineer. Seeding that occurs during this time frame may require additional measures to protect seedlings until they are well established, at no additional expense to the City.
- C. Seeding shall not be performed during periods of any snow or ice cover. Winter seeding may be allowed during periods of thaw prior to refreezing, providing that areas of snow are no longer present. Seed shall not be placed in areas of standing or moving water.
- D. Do not apply seeds, seed mixtures, or slurries with seeds when wind conditions are such that materials would be carried beyond designated areas or materials would not be uniformly applied. Do not undertake seeding and planting activities during stormy weather when excessive precipitation may result in washing of seeds and plantings away from location intended. Do not install plant materials during periods of temperature extremes when atmospheric temperature may drop below 36 degrees F or rise above 90 degrees F.
- E. Seed installation method(s) will be approved by the Engineer prior to seed installation. Seed installation method(s) selected shall insure complete coverage of the areas to be seeded. Seed installation methods selected shall be dependent on the season of installation (*i.e.*, spring vs. fall) and shall be appropriate for the type of seed installed. If the seed is installed in the spring, large seed may be installed with a no-till drill or, if one is not available, shall be broadcast followed by pressing the seed with a roller or cultipacker. If the seed is installed in the fall, the large seed may be broadcast without pressing since the frost heave experienced in the following winter will accomplish this.
- F. Seed installation method(s) shall insure good contact between seed and mineral soil. Scarify or loosen topsoil as necessary to bring it to the proper condition. Remove foreign matter larger than 1-inch diameter. Lightly rake or drag the topsoil in the planted area following seed application, resulting in no more than 1/8-inch cover over the seed.
- G. In no event shall the small seed be rolled or cultipacked since this seed requires surface sowing. Small seed shall be installed separately from the large seed and shall be mixed with a seed carrier to ensure proper distribution. A carrying agent such as vermiculite must be pre-approved by the Engineer. Sawdust and sand are inadequate carriers and will not be permitted.
- H. Hydro seeding will not be permitted.
- I. Break bulk seed mix down into smaller quantities for better management to provide even distribution over the site. The areas to be seeded shall be crossed twice, the second time shall be perpendicular to the first pass, to ensure even seed distribution.
- J. Seeding must be coordinated with topsoil placement, turf reinforcing mat, and erosion control blanket installation.
- K. Unless otherwise specified on the plans, on all disturbed areas including access routes to remain, the CONTRACTOR shall install a minimum of 4 inches of topsoil prior to seeding.

3.03 MAINTENANCE

- A. Maintenance shall include all measures necessary to establish and maintain vegetation in a vigorous and healthy growing condition.
- B. Maintenance of seeding shall begin immediately after provisional acceptance is granted and shall continue as required until final acceptance at the end of the warranty period. Maintenance required prior to provisional acceptance shall be included in the contract unit price for each plant.
- C. The Contractor shall promptly perform needed maintenance.
- D. The Contractor shall irrigate all seed adequately to maintain an optimum supply of moisture within the root zone. Reoccurring overly dry or wet conditions shall be grounds for rejection of plant material. Water shall come from a source approved by the Engineer. Water shall not be applied with a force that will displace the seed or mulch blankets or cause soil erosion, and shall not be applied so quickly that the seed or mulch blankets cannot absorb it. Water is to be supplied for plants that is clean, free from toxic amounts of salt, oil, acid alkali, organic matter or other substances harmful to plants.
- E. Watering seed during the establishment period shall be considered as incidental to the seeding work unless a pay item for watering and cultivating has been included in the Bid Form.
- F. The growing season is the period from April 1 to October 15 each year.
- G. Additional watering will be required during the first growing season to obtain the required plant cover, at no additional expense to the City. Soil moisture must be sufficient to stimulate germination and sustain viable plant growth. Once areas have been watered, watering must continue during the growing season to maintain optimal soil moisture. Water shall be applied to moisten the soil to a minimum depth of three inches, in a manner that does not cause erosion. It will be the Contractor's responsibility to furnish adequate equipment for watering and an appropriate source and supply.
- H. Restored areas shall be protected and maintained after seeding by watering correcting all erosion and settlement until acceptance by the Engineer.
- I. Maintenance of the seeding areas shall consist of the following: mowing (or weed-whacking) vegetation to prevent the flowering and seeding of perennial and annual weeds throughout the growing season; removing invasive species via hand pulling; spot seeding with species from the original seed mix; and other practices considered necessary by the Contractor (and approved by Engineer) to achieve the required conditions for final acceptance.
- J. Maintenance visits will include, but not be limited to, at least three times during the growing season, during which activities will be undertaken such as mowing or cutting the plants to 6"-8" when the plantings reach a 12"-18" height, and spot spraying and hand-pulling of undesirable plants. The contractor shall supply projected dates, times, and activities of maintenance visits to the ENGINEER at the beginning of each growing season. The maintenance visit activities shall be approved by the Engineer prior to the work.
- K. Any herbicide or pesticide intended for use on site must be approved by the ENGINEER prior to use.
- L. Herbicide shall have Glyphosate as the primary active ingredient, and shall be labeled for aquatic use. An aquatic-approved surfactant, such as Cygnet Plus, is required to increase adherence of herbicide to plant material.
- M. The applicator must have a certified pesticide applicator license (that includes the category of aquatic pest control) from the State of Michigan. Contractor shall submit previous work experience documentation of applicator and plant specialist for approval to the Engineer.

N. The use of insecticide or fungicide is not recommended and will only be approved under extreme circumstances. Under no circumstance will insecticide application be allowed in areas where the risk of surface water contamination exists.

3.04 FINAL ACCEPTANCE AND WARRANTY

A. The Contractor is responsible for establishing vigorous native plant cover by the end of the three year warrantee period.

B. Provisional Acceptance will be granted upon the successful completion of all seeding and the Engineer’s verification that all work has been installed in accordance with the Plans and Specifications. Final Acceptance will be granted at the end of the third full growing season following the seed installation.

C. The Contractor shall establish a dense cover of specified species in all areas seeded under the contract. These areas shall be maintained until Final Acceptance of the work. For all seeded zones, the Engineer shall conduct warranty field inspections of all seeded areas at the end of the first and second growing seasons following seeding.

D. The Engineer and Contractor shall conduct the final acceptance inspections before the end of the Warranty period. Final acceptance will be granted if the erosion control fence has been removed and the seeded areas achieve 90% total cover.

E. Within all seeded areas after the first full growing season, any bare areas with less than 30% cover by seeded species that are 30 square feet in size or greater shall be reseeded. These areas shall be reseeded as originally specified at no additional cost to the Owner.

F. Within all seeded areas after the Second full growing season, any bare areas with less than 50% cover by seeded species that are 30 square feet in size or greater shall be reseeded. These areas shall be reseeded as originally specified at no additional cost to the Owner.

G. Areas which do not meet the contract requirements for Final acceptance shall be reseeded within acceptable planting dates as directed by the Engineer. No additional payment will be made for reseeded.

H. The final acceptance of the seeding work will be made by the Engineer and the Contractor just before the warranty period expires. All seeding shall be established and the site shall be cleaned-up, prior to the inspection.

- 1. The final acceptance inspection of the seeding areas shall be made during September of the third growing season.
- 2. Areas that do not meet the contract requirements shall be reseeded to the original project specifications and within acceptable seeding dates as directed by the Engineer.

3.05 MEASUREMENT AND PAYMENT

A. The completed work shall be paid for at the contract unit price for the following contract items (pay items):

<u>CONTRACT ITEM</u>	<u>PAY UNIT</u>
Stabilize all disturbed areas with specified seed mixes	Lump Sum

B. Seeding will be estimated in place by percent complete meeting the specified standards, and shall include all labor, equipment, seed, water, Maintenance and Warranty as required to meet the requirements of this specification, providing a uniform, weed-free vegetation of the specified mixes.

C. Payment Schedule for the above items shall be as follows:

<u>Provisional</u>	<u>Second Full</u>	<u>Final</u>
<u>Acceptance</u>	<u>Growing Season</u>	<u>Acceptance</u>
50%	25%	25%

Upland Prairie Seed Mix shall include the following species or approved equals:

<u>Scientific Name</u>	<u>Common Name</u>	<u>LBS/AC</u>
Agropyron trachycaulum	Slender Wheat	1.00
Andropogon gerardii	Big Bluestem	1.50
Andropogon scoparius	Little Bluestem	4.00
Asclepias tuberosa	Butterfly Weed	0.063
Aster laevis	Smooth Blue Aster	0.188
Aster novae-angliae	New England Aster	0.125
Carex bicknellii	Bicknell's Oval Sedge	0.064
Coreopsis tripteris	Tall Coreopsis	0.125
Elymus Canadensis	Canada Wild Rye	1.00
Elymus virginicus	Virginia Wild Rye	1.00
Heliopsis heianthoides	False Sunflower	0.188
Lespedeza capitata	Roundhead Bushclover	0.094
Liatris aspera	Blazing Star	0.125
Lupinus perennis occidentalis	Lupine	0.125
Monarda fistulosa	Bergamot	0.063
Panicum virgatum	Switchgrass	0.250
Penstemon digitalis	Foxglove Beardtongje	0.125
Potentilla arguta	Prairie cinquefoil	0.063
Ratibida pinnata	Yellow Coneflower	0.500
Rudbeckia hirta	Black Eyed Susan	0.250
Silphium terebinthinaceum	Prairie Dock	0.020
Solidago rigida	Stiff Goldenrod	0.125
Solidago speciosa	Showy Goldenrod	0.125
Verbena stricta	Hoary Vervain	0.250
Vernonia fasciculata	Common Ironweed	0.125
Zizia aurea	Golden Alexander	0.063

Wet to Mesic Seed Mix shall include the following species or approved equals:

<u>Scientific Name</u>	<u>Common Name</u>	<u>LBS/AC</u>
Andropogon gerardii	Big Bluestem	3.00
Andropogon scoparius	Little Bluestem	2.00
Asclepias Incarnata	Swamp Milkweed	0.063
Asclepia tuberosa	Lanceleaf Coreosis	0.063
Aster laevis	Smooth Blue Aster	0.016
Aster novae-angliae	New England Aster	0.031
Carex bebbii	Bebb's Sedge	0.500
Elmys canadensis	Canada Wild Rye	1.000
Eupatorium perfoliatum	Boneset	0.015
Eupatorium purpureum	Joe Pye Weed	0.063
Glyceria striata	Fowl Manna Grass	0.063
Hypericum pyramidiatum	Great St. Johns Wort	0.063
Iris virginica	Blueflag Iris	0.031
Juncus tenuis	Path Rush	0.031
Liatris spicata	Spiked Blazing Star	0.188
Lobelia siphilatica	Great Blue Lobelia	0.031
Monarda fistulosa	Bergamot	0.063
Panicum virgatum	Switch Grass	0.031

Poa palustris	Marsh Blue Grass	0.063
Rudbeckia hirta	Black Eyed Susan	0.250
Rudbeckia pinnata	Yellow Coneflower	0.250
Silphium terebinthinaceum	Prairie Dock	0.020
Solidago rigida	Stiff Goldenrod	0.125
Solidago speciosa	Showy Goldenrod	0.125

If certain quantities of plants are not available, substitutions may be requested in writing subject to Parks and Recreation approval.

City of Ann Arbor
Technical Specifications
**THREE YEAR MAINTENANCE PLAN
FOR RAIN GARDEN**

SCOPE OF THE WORK

This specification is to cover a 3-year maintenance plan for the rain garden site (starting from fall, 2012 to fall, 2015). The goal is to have high quality native plant meadows consisting of Michigan native forbs, grasses and wildflowers on site. The contractor is to have experience working with native plant communities, the planting and care of them. References shall be provided. The limits of maintenance shall include all naturalized plantings within rain garden area.

Generally, the maintenance of the new installation shall consist of replacing, weeding, spraying, repairing of gully erosion or washouts and keeping the installation free of insects, diseases and weeds.

The contractor must guarantee that adequate skilled staff is available to achieve each component of the project during the specified time period. The contractor shall not rely on the allocation of City staff to assist in any component of the project in preparing his/her bid. The successful bidder is responsible for his/her own equipment.

Follow-up maintenance shall consist of the following:

- Mowing vegetation to prevent flowering of perennial weeds
- Removing invasive species from all areas through hand pulling and herbicide
- Spot seeding with species from original mix and replacing plugs
- Burning to discourage weed growth
- Collection of seeds for additional spot seeding

The contractor shall provide a written report to the City of all maintenance practices at least twice per season, and shall meet with the City's representative on site at least once per season to report on maintenance progress.

Technical Specification for NATIVE PLANTING

PART 1 – GENERAL

1.01 DESCRIPTION

- A. This work shall consist of planting preparation, bare root tree installation, container shrub installation, disposal of excess and/or unsuitable materials, maintenance and warranty, as indicated on the plans or as directed by the ENGINEER.
- B. All work shall be performed in accordance with Section 815 of the 2003 Michigan Department of Transportation Standard Specifications for Construction and the City of Ann Arbor Public Services Department Standard Specifications for Construction (Orange Book), the best modern practices such as the standards set forth by the American Association of Nurserymen, and as specified herein. In the event that these specifications conflict, the more stringent requirements shall govern.
- C. An on-site meeting with the LANDSCAPE CONTRACTOR and the ENGINEER shall be scheduled by the ENGINEER prior to planting any plant material.

1.02 SUBMITTALS

- A. Within thirty (30) days after award of the contract the CONTRACTOR shall provide nursery sources and documentation of species availability for plant stock to the ENGINEER.
- B. The CONTRACTOR shall provide tree and shrub plant stock certificates containing the following information to the OWNER a minimum of one (1) month prior to the time of planting:
 - 1. Botanical name, including cultivar, and common name.
 - 2. Quantity
 - 3. Size
 - 4. Type (e.g., B&B, container, bare root, live stake)
 - 5. Origin (location grown and genotype)
 - 6. Name, address and phone number of supplier.
- C. The CONTRACTOR shall not make substitutions if specified landscape material is not obtainable. Submit proof of non-availability to ENGINEER together with proposal for use of equivalent material. All substitutions for materials or execution shall be approved by the ENGINEER in writing a minimum of one (1) month prior to construction. The ENGINEER reserves the right to require a sample of substituted material(s) prior to approval for construction.

1.03 QUALITY ASSURANCE

- A. Installation of trees and shrubs shall be carried out by LANDSCAPE CONTRACTORS and their employees who are thoroughly experienced and skilled in the work and who are completely familiar with the specified requirements and methods needed for proper performance of the work in this section. The LANDSCAPE CONTRACTOR shall have a minimum of five (5) years of documented experience in comparable work, particularly bare root and native wetland plant installation. Upon request, the contractor must supply documentation of such experience with at least three successful projects completed in the last five years. This documentation shall include at a minimum, the number and type of plants installed, number of acres planted, year project was completed, along with the project name, contact person, phone number, and address.
- B. The CONTRACTOR shall warrant all plant material to be true to botanical name.
- C. All plant stock shall be inspected and approved by the ENGINEER prior to installation. The ENGINEER shall reserve the right to refuse any plant material that is unacceptable upon delivery to the site.

1.04 DELIVERY, STORAGE, AND HANDLING

- A. Moving and storage of plant materials: CONTRACTOR shall take all precautions customary in good trade practice in preparing plants for moving. Workmanship that fails to meet the highest standards will be rejected.
1. Spray deciduous plants in foliage with an approved antitranspirant immediately after digging to prevent dehydration.
 2. Legibly tag plants with botanical name and size in accordance with the standards of practice of the American Nursery and Landscape Association.
 3. Dig, pack, transport, and handle plants with care to ensure protection against injury. Fully protect plants from damage by sun, wind, drought, water and other injurious conditions during transportation to site and during temporary storage before planting.
 4. Inspection certificates required by law shall accompany each shipment invoice or order to stock and on arrival. The certificate shall be filed with the OWNER.
 5. No plant shall be bound with rope or wire in a manner that could damage or break the branches.
- A. Plant material delivery shall be the same day as planting. No plants shall be stored at the site without permission of the ENGINEER. Plants shall be carefully loaded and unloaded so as not to damage branching or root mass. Dropping of material will not be allowed. Plants in full leaf shall be thoroughly wetted down and completely covered with a wet tarp during transportation.
- B. All roots must be kept in a moist condition.
- C. Digging shall be done in the dormant season. Plant material which is poorly packed, or which arrives with the roots in a dry condition, as a result of improper packing, delay in transit, or from any other cause, will not be accepted. Stock shall be handled in such a manner that the roots shall remain intact, the branches unbroken, and the bark intact and not loosened from the wood. Stock shall be protected from drying and from temperatures below 50 degrees F and in excess of 90 degrees F prior to planting.

PART 2 – PRODUCTS

2.01 TREES AND SHRUBS

- A. Trees and shrubs shall be quality, nursery-grown stock with adequate root growth. Nursery stock shall meet the standards of the current edition of the American Standard for Nursery Stock as published by the American Association of Nurserymen, as well as the standards of Section 917 of the Michigan Department of Transportation Standard Specifications for Construction.
- B. Provide plants typical of their species or variety with normal, densely developed branches and vigorous, fibrous root systems. Provide only sound, healthy, vigorous plants free from insect pests, diseases, and physical injury. All plants shall have a fully developed form without voids and open spaces. Plants shall be in a moist, vigorous condition, free from dead wood, bruises, or other root or branch injuries.
- C. Balled and burlapped plants: dig balled and burlapped plants with firm, natural balls of earth of sufficient diameter and depth to encompass the fibrous and feeding root system necessary for full recovery of plant, provide ball sizes complying with the latest edition of the American Standard for Nursery Stock. Cracked or mushroomed balls are not acceptable.
- D. Container stock: grown in a container for sufficient length of time for the root system to have developed to hold its soil together, firm and whole. No plants shall be loose in container. Container stock shall not be pot bound.
- E. All plants shall be nursery grown under climatic conditions similar to those in the locality of the project, for at least one year.

- F. Stock furnished shall be at least the minimum size indicated on the drawings. Larger stock is acceptable, at no additional cost and providing the larger plants will not be cut back to the size indicated on the drawings.
- G. The height of the tree, measured from the crown of the roots to the average height of the top of the tree, shall not be less than the minimum size designated in the plant list.
- H. No pruning wounds shall be present with a diameter of more than 1 inch and such wounds must show vigorous bark on all edges.
- I. Shrubs and small plants shall meet the requirements for spread and height indicated in the plant list.
 - 1. The measurements for height shall be taken from the ground level to the average height of the top of the plant and not the longest branch.
 - 2. Single stemmed or thin plants will not be accepted.
 - 3. Side branches shall be generous, well-trimmed, and the plant as a whole well-bushed to the ground.

2.02 BARE ROOT TREES

- A. All specified bare-root trees shall be well rooted with a dense, fibrous root system produced by being grown in an air-pruning and fertilization system that stimulates lateral production of an extensive fine root mat. Minimum height and caliper as shown on plans.
- B. Acceptable stock shall be Forrest Keeling Nursery RPM ® stock (1-800-356-2401) or other supplier of equivalent material approved in writing by the ENGINEER.

2.03 WEED BARRIER

- A. Synthetic, non-woven, needle punched fabric weighing 187 gm per m² with a minimum grab tensile strength of 3.5 pound and permeability of 0.1 inch/second.

2.04 METAL FASTENERS

- A. Fasteners shall be 11 gauge steel wire formed into "U" shaped staples, 6 inches long.

2.05 TOPSOIL

- A. Quantity: The CONTRACTOR shall be responsible for estimating the quantity of imported topsoil necessary to obtain the necessary depth of topsoil for planting. The approximate in-place quantity estimated on the plans is for information purposes only. The CONTRACTOR shall report any discrepancy between the estimate on the Plans to the ENGINEER.
- B. Imported topsoil shall be friable sandy loam capable of supporting optimal plant growth and development. It shall be free of clay lumps, subsoil, invasive weeds and seeds, stones, sticks and other extraneous materials.
- D. Analysis for existing and imported topsoil shall be done at the CONTRACTOR'S expense and shall be submitted to ENGINEER for approval prior to use. CONTRACTOR shall supply recommendations for starter fertilizer for both planting and seeding areas.
- E. The structural topsoil analysis for the wetland mitigation area shall include the following and be within the listed parameters:
 - Clay content: 5-10%
 - pH range: 6.0-7.0
 - Organic matter content: 5-20%

- F. The chemical soil analysis for the wetland mitigation area shall include the following and soils shall be adjusted with starter fertilizer based on the testing agencies recommendations:

- Available Phosphorus
- Exchangeable Potassium
- Magnesium
- Calcium
- Cation Exchange Capacity
- Percent Base Saturation of Cation Elements
- Available Nitrogen

- G. The structural topsoil analysis for other areas shall include the following and be within the listed parameters:

- Clay content: 5-15%
- pH range: 6.0-7.5
- Organic matter content: 2-5%

- H. The chemical soil analysis for other areas shall include the following and soils shall be adjusted with starter fertilizer based on the testing agencies recommendations:

- Available Phosphorus
- Exchangeable Potassium
- Magnesium
- Calcium
- Cation Exchange Capacity
- Percent Base Saturation of Cation Elements
- Available Nitrogen

- I. Testing and recommendations for starter fertilizer for wetland mitigation area and other area topsoil may be performed through A&L Great Lakes Laboratories, Inc., Fort Wayne Indiana 1.260.483.4759.

2.06 COMPOST

- A. Compost shall be used only from City of Ann Arbor, available from WeCare Organics 1.734.477.0334, or approved substitution.

PART 3 – EXECUTION

3.01 TOPSOIL PLACEMENT AND FINE GRADING

- A. The Contractor shall be responsible for layout of all topsoil mounds. The contractor shall contact the Engineer after topsoil mound layout is complete for field review. The Engineer reserves the right to adjust topsoil mound locations, without adjusting topsoil quantities, to meet field conditions, at no additional cost to the Owner.
- B. Topsoil mounds shall be placed according to the drawings and maintained until time of tree planting. Contractor is responsible for providing adequate in place topsoil to plant the trees and shrubs as specified.

3.02 PLANT LAYOUT

- A. The Contractor shall be responsible for layout of all plants. The contractor shall contact the Engineer after plant layout is complete for field review. The Engineer reserves the right to adjust plant material locations, without adjusting plant quantities, to meet field conditions, at no additional cost to the Owner.

3.03 PLANTING SCHEDULE

- A. The bare root plants must be installed between March 1 and May 15 or October 15 and November 15, except with written permission of the ENGINEER.
- B. The container plants must be installed between May 1 and June 15 or October 1 and November 15.
- C. At the time of planting wetland areas, it is expected that soil moisture will be at or near saturation. The CONTRACTOR is responsible for planting under favorable weather conditions and recommended season for plant survival and establishment.

3.04 DAMAGED AREAS

- A. The CONTRACTOR must take every precaution to minimize rutting and damage to areas where work is not specified. All damaged areas, as determined by the Engineer, shall be regraded, reseeded and replanted as specified.

3.05 EXCAVATION

- A. If hand-held rotating augers or other mechanical diggers are used to excavate holes, the vertical sides of the pits shall be scarified, fractured, or otherwise broken down to eliminate impervious surfaces. Excavated soil must be consolidated adjacent to the planting pits and not spread over adjacent areas where work is not specified.
- B. Installation of all plant material shall be in accordance with the standards set forth by the American Association of Nurserymen.

3.06 GEOTEXTILE WEED BARRIER

- A. Immediately following planting at the site, install a 3 foot x 3 foot (minimum) section of fabric around all shrubs and anchor with a minimum of 9 metal fasteners (1.5 foot on center) per plant. The fabric shall be one piece and shall only contain one cut to facilitate installation around the plant. Overlap cut edges by 3 inches and anchor with metal fasteners.

3.07 STAKING

- A. Staking shall be as shown on the plans.

3.08 MAINTENANCE

- A. Maintenance shall include all measures necessary to establish and maintain plants in a vigorous and healthy growing condition.
- B. Maintenance of plantings shall begin immediately after provisional acceptance is granted and shall continue as required until final acceptance at the end of the warranty period. Maintenance required prior to provisional acceptance shall be included in the contract unit price for each plant.
- C. The Contractor shall promptly perform needed maintenance.
- D. The Contractor shall irrigate all plants adequately to maintain an optimum supply of moisture within the root zone. Reoccurring overly dry or wet conditions shall be grounds for rejection of plant material. Watering and cultivating shall be performed in accordance with Section 815 of the 2003 MDOT Standard Specifications for Construction. Water shall come from a source approved by the Engineer. Water shall not be applied with a force that will displace mulch or cause soil erosion, and shall not be applied so quickly that the mulch and plants cannot absorb it.
- E. Watering and cultivating trees and shrubs during the establishment period shall be considered as

incidental to the tree and shrub planting work unless a pay item for watering and cultivating has been included in the Bid Form. Water is to be supplied for plants that is clean, free from toxic amounts of salt, oil, acid alkali, organic matter or other substances harmful to plants.

- F. Stakes and guys shall be adjusted or replaced as required during the first year, then removed by the Contractor.
- G. The Contractor shall remove and replace dead and unacceptable plants as their condition becomes apparent at his/her sole expense.
- H. Selective weed control by hand weeding shall be done if competition threatens the establishment of plantings.
- I. Any herbicide or pesticide intended for use on site must be approved by the ENGINEER prior to use.
- J. Herbicide shall have Glyphosate as the primary active ingredient, and shall be labeled for aquatic use.
- K. The applicator must have a certified pesticide applicator license (that includes the category of aquatic pest control) from the State of Michigan. Contractor shall submit previous work experience documentation of applicator and plant specialist for approval to the Engineer.
- L. The use of insecticide or fungicide is not recommended and will only be approved under extreme circumstances. Under no circumstance will insecticide application be allowed in areas where the risk of surface water contamination exists.

3.09 FINAL ACCEPTANCE AND WARRANTY

- A. Provisional Acceptance will be granted upon the successful completion of all tree planting operations and the Engineer's verification that all work has been installed in accordance with the Plans and Specifications. Final Acceptance will be granted at the end of the third full growing season following the tree installation.
- B. After receiving a Notice of Provisional Acceptance, all trees and shrubs shall be maintained in a vigorous condition and warranted against defects including death, improper maintenance, and unsatisfactory growth until:
 - 1. October 15th, of the year which is two years following the plantings, for fall plantings, or
 - 2. June 15th, of the year which is two years following the plantings, for spring plantings.
- C. The plants will be inspected by the Engineer for a two year establishment period following installation. Any plants that did not survive will be replaced by the contractor at no additional cost. Replacement plants and planting operations shall be in accordance with the original specifications. Replacements shall be made no later than the next succeeding planting season. Fully restore areas damaged by replacement operations to their original and specified condition.
- D. The Engineer and Contractor shall conduct the final acceptance inspections before the end of the Warranty period. Final acceptance will be granted when, in the opinion of the Engineer, all trees are growing and are in a healthy condition.
- E. Final Acceptance Inspection. - The final acceptance inspection of the tree work will be made by the Engineer and the Contractor just before the warranty period expires. All trees shall be growing and in a healthy condition. The site shall be cleaned-up, prior to the inspection.
 - 1. The final acceptance inspection of the trees shall be made during September of the third year.

2. Trees that do not meet the contract requirements shall be replanted as originally described in the original project specifications and within acceptable planting dates as directed by the Engineer.
- F. Upon completion of plant installation, remove from the site and legally dispose of all trash and debris including any material removed during construction. Restore existing wetland and upland areas damaged by operations under the contract.

3.10 MEASUREMENT AND PAYMENT

- A. The completed work shall be paid for at the contract unit price for the listed plants.
- B. Trees will be measured in place and paid by each and shall include all labor, equipment, materials, water, maintenance and warranty as required to meet the requirements of this specification.
- C. Payment schedule for each of the above items shall be as follows:
 1. Provisional Acceptance - After the initial installation of the trees, 50% of each unit price shall be certified for payment.
 2. After the Second full growing season, and when all the above referenced criteria have been met, an additional 25% of each unit price shall be certified for payment.
 3. Final Acceptance - After the Third full growing season, and when all the above referenced criteria have been met, an additional 25% of each unit price shall be certified for payment. This payment shall constitute 100% and final payment.

END OF SECTION

CITY OF ANN ARBOR
SPECIAL PROVISION
FOR
REMOVAL OF CURB AND GUTTER, ANY TYPE

AA:CEC

1 of 1

05/31/12

Description

This work shall consist of removing curb, curb and gutter, gutter, and drive openings, of any size, thickness, or amount of reinforcing steel, in accordance with Section 204 of the 2012 Michigan Department of Transportation (MDOT) Standard Specifications for Construction, and as specified herein, and backfilling the resulting void as needed with MDOT Class II granular material.

Materials

Granular Material, Class II

Section 902

Construction Methods

The construction methods shall conform to Section 204.03 of the 2012 MDOT Standard Specifications for Construction, except as modified herein.

All concrete removal items shall be saw-cut full depth at the removal limits. Any over excavation resulting from the removal operations shall be backfilled with MDOT Class II Granular Material and compacted to 95% of its maximum unit weight. This will not be paid for separately, but shall be included in the respective removal items.

All removed materials shall be removed from the project site within seven (7) calendar days of their removal.

Any resulting trench, hole, or pit resulting from the removal operations shall be backfilled with MDOT Class II Granular Material compacted to 95% of its maximum unit weight. This work will not be paid for separately, but shall be included in the respective removal items.

Measurement and Payment

The removal of any type or size, of curb, curb and gutter, gutter, or drive opening will be paid for as "Curb and Gutter, Any Type, Rem".

Pay Item

Pay Unit

Curb and Gutter, Any Type, Rem

Foot

The unit price shall include all labor, material and equipment needed to complete the work as described above.

CITY OF ANN ARBOR
SPECIAL PROVISION
FOR
CURB AND GUTTER, CONC, SPECIAL

AA:CEC

1 of 1

05/31/12

Description

This work shall consist of constructing concrete curb & gutter in accordance with Section 802 of the 2012 Michigan Department of Transportation (MDOT) Standard Specifications for Construction, and as specified herein.

Materials

The materials shall meet the requirements as specified in Section 802.02 of the 2012 MDOT Standard Specifications for Construction, and as specified herein.

The concrete shall be Grade P1 containing 480 lbs/ft³ cement and 72 lbs/ft³ Type C fly ash with 6AA coarse aggregate.

It shall be the Contractor's sole responsibility to propose specific concrete mix designs which meet the requirements of this Special Provision.

Construction Methods

Curb and Gutter, Conc, Special shall be 2 feet wide barrier curb & gutter and constructed as shown in the City of Ann Arbor Standard Plan SD-R-1.

Measurement and Payment

The completed work as measured shall be paid for at the contract unit price for the following contract items (pay items):

Pay Item

Pay Unit

Curb and Gutter, Conc, Special

Foot

Concrete curb and gutter will be paid for as "Curb and Gutter, Conc, Special". The contract unit prices for "Curb and Gutter, Conc, Special" will be measured in length by feet and will be payment in full for all labor, equipment, and material needed to properly complete this work.

CITY OF ANN ARBOR
SPECIAL PROVISION
FOR
TURF ESTABLISHMENT

AA:CEC

1 of 2

05/31/12

Description

This work shall consist of furnishing and placing 4" of Engineer-approved topsoil and hydroseeding the disturbed lawn areas as indicated on the plans. The related work of preparing the earth bed, furnishing, and placing the topsoil, furnishing the seed mixtures, furnishing the fertilizer, sowing the seed, placing mulch or mulch blankets, and watering shall conform to Section 816, Turf Establishment, of the Michigan Department of Transportation (MDOT) 2012 Standard Specifications for Construction, and as specified herein.

Materials

The materials shall meet the requirements specified in the 2012 MDOT Standard Specifications for Construction as designated, as specified herein, and as approved by the Engineer:

- Seed shall be THM seed mixture as described in Table 816-1.
- Fertilizers shall be a Class A. The percentages by weight shall be 10-10-10.
- The seed, fertilizer, and adhesive (mulch binder) shall be mixed together and applied at one time.
- Water used shall be obtained from fresh water sources and shall be free from injurious chemicals and other toxic substances.

Maintenance and Acceptance

It is the responsibility of the Contractor to establish a dense lawn of permanent grasses, free from mounds and depressions prior to final acceptance and payment of this project. Any portion of a sodded area that "browns-out" or does not firmly knit to the soil base, or any portion of a seeded area that fails to show a uniform germination, shall be re-sodded or re-seeded. Such re-sodding or re-seeding shall be at the Contractor's expense and shall continue until a dense lawn is established.

The Contractor shall maintain all lawn areas until they have been accepted by the Engineer. Lawn maintenance shall begin immediately after the grass seed or sod is in place, and shall continue until final acceptance with the following requirements:

- Lawns shall be protected and maintained by watering, mowing, and reseeded as necessary, until the period of time when the final acceptance and payment is made by the Engineer for the project, to establish a uniform, weed-free, stand of the specified grasses. Maintenance includes deposition of additional topsoil, and re-sodding or re-seeding, all as may be required to correct all settlement and erosion until the date of final acceptance.
- Damage to seeded areas resulting from erosion shall be repaired by the Contractor at the Contractor's expense. Scattered bare spots in seeded areas will not be allowed over three (3) percent of the area nor greater than 6"x 6" in size.

When the above requirements have been fulfilled, the Engineer will accept the lawn.

Basis of Payment

The completed work as measured for "Topsoil Surface, 4 inch", and "Hydroseeding" will be paid for at the contract unit prices for the following contract items (pay items):

<u>Pay Item</u>	<u>Pay Unit</u>
Topsoil Surface, 4 inch	Square Yard
Hydroseeding	Square Yard

"Topsoil Surface, 4 inch" and "Hydroseeding" will be measured by area in square yards and will be paid for at the contract unit prices which shall be payment in full for all labor, materials, and equipment needed to accomplish this work.

Topsoil placement shall occur at the locations called for on the plans or, as directed by the Engineer. The unit price of placing the topsoil shall include the grading of the area to receive the topsoil, preparing the earth bed, spreading and raking the topsoil to provide a uniform surface free of large clods, lumps, rocks, brush, roots, or other deleterious materials, as determined by the Engineer.

The hydroseeding shall be placed on all disturbed lawn areas as called for on the plans, and shall include seed, fertilizer, mulch, mulch adhesive, and watering. If the Engineer directs the placement of straw mulch blankets, they will be paid for at the corresponding contract unit price. Watering will **not** be paid for separately. Any damage or soiling to signs shall be repaired and/or cleaned by the Contractor at the Contractor's sole expense.

CITY OF ANN ARBOR
SPECIAL PROVISION
FOR
SOIL EROSION CONTROL INLET FILTER

AA:CEC

1 of 1

05/31/12

Description

This work consists of installing and maintaining inlet filters in accordance with City of Ann Arbor Standards, and as shown on the plans. Filters shall be placed over existing and proposed inlets in order to minimize the erosion of soil and the sedimentation of water courses, and the related work includes the installation, maintenance and removal of the filter cloth, cleaning as required during the project, and replacement of filters if required by the Engineer so as to provide a well drained site.

Materials

The inlet filters shall be in accordance with the REGULAR FLOW SILTSACK® manufactured by ACF Environmental (800) 448-3636, or approved equal.

The Contractor shall submit product data sheets and a sample of the filter material for inlet filters for Engineer approval prior to ordering materials.

Construction Methods

The Contractor shall be install, maintain, and clean inlet filters in accordance with the manufacturer’s specifications and as directed by the Engineer. The Contractor shall dispose of debris off-site.

Measurement and Payment

The completed work of **Soil Erosion Control, Inlet Filter** will be paid for at the contract unit price for the following contract item (pay item):

<u>Pay Item</u>	<u>Pay Unit</u>
Soil Erosion Control, Inlet Filter	Each

Soil Erosion Control, Inlet Filter will be measured by the unit and will be paid for at the contract unit price per each, for which price shall be payment in full for all labor, equipment, and materials needed to furnish, install, maintain, clean and remove the inlet filter.

**DETAILED SPECIFICATION
FOR
ITEM #210 – STABILIZATION GEOTEXTILE**

DESCRIPTION

This work shall consist of furnishing, installing, stabilization geotextile as directed by the Engineer, in accordance with the manufacturer’s installation guidelines and in accordance with the 2012 edition of the MDOT Standard Specifications for Construction and the City Standard Specifications, except as modified herein.

MATERIALS

Materials must meet the requirements of Section 910 of the 2012 edition of the MDOT Standard Specifications for Stabilization Geotextile.

CONSTRUCTION METHODS

Install the stabilization geotextile on prepared grades in accordance with the manufacturer’s recommendations. Do not operate equipment required to place backfill or cover materials directly on the geotextile. Eliminate wrinkles or waves which may develop in the geotextile during placement. Either shingle-lap (minimum of 2 feet) or seam all longitudinal and transverse joints in the geotextile. Field or factory seams, sewn or sealed, must meet specified grab tensile strength. Install seams facing upward to facilitate inspection.

MEASUREMENT AND PAYMENT

The completed work as measured for this item of work will be paid for at the Contract Unit Price for the following Contract (Pay) Item:

PAY ITEM

PAY UNIT

Stabilization Geotextile

Square Yard

Payment for Stabilization Geotextile will be measured in place to the limits specified by the Engineer. Overlap areas are not included in the measurement for payment. The unit price for this item of work shall include all labor, material, and equipment costs to perform all the work specified in the Standard Specifications and as modified by this Detailed Specification.

CITY OF ANN ARBOR
SPECIAL PROVISION
FOR
PROPERTY MARKERS/MONUMENTS

AA:CEC

1 of 1

05/31/12

The Contractor shall take precautions not to move or destroy any monuments or stakes marking the boundaries of property along or near the work. The Contractor shall notify the Engineer in sufficient time so property markers and monuments may be properly protected or witnessed for later replacement by the Engineer. If a property marker, monument, or the like are disturbed or damaged by the Contractor, they shall be re-set by the City at the Contractor's expense.

APPENDIX A

FAIR EMPLOYMENT PRACTICE

The consultant, its agents or sub-contractors, shall comply with all requirements of Chapter 112 of Title IX of the Code of the City of Ann Arbor and in particular the following excerpts there from:

9:161 NONDISCRIMINATION BY CITY CONTRACTORS

- (1) All contractors proposing to do business with the City of Ann Arbor shall satisfy the nondiscrimination administrative policy adopted by the City Administrator in accordance with the guidelines of this section. All contractors shall receive approval from the Director prior to entering into a contract with the City, unless specifically exempted by administrative policy. All City contractors shall take affirmative action to insure that applicants are employed and that employees are treated during employment in a manner which provides equal employment opportunity and tends to eliminate inequality based upon race, national origin or sex.
- (2) Each prospective contractor shall submit to the City data showing current total employment by occupational category, sex and minority group. If, after verifying this data, the Director concludes that it indicates total minority and female employment commensurate with their availability within the contractor's labor recruitment area, i.e., the area from which the contractor can reasonably be expected to recruit, said contractor shall be accepted by the Director as having fulfilled affirmative action requirements for a period of one year at which time the Director shall conduct another review. Other contractors shall develop an affirmative action program in conjunction with the Director. Said program shall include specific goals and timetables for the hiring and promotion of minorities and females. Said goals shall reflect the availability of minorities and females within the contractor's labor recruitment area. In the case of construction contractors, the Director shall use for employment verification the labor recruitment area of the Ann Arbor-Ypsilanti standard metropolitan statistical area. Construction contractors determined to be in compliance shall be accepted by the Director as having fulfilled affirmative action requirements for a period of six (6) months at which time the Director shall conduct another review.
- (3) In hiring for construction projects, contractors shall make good faith efforts to employ local persons, so as to enhance the local economy.
- (4) All contracts shall include provisions through which the contractor agrees, in addition to any other applicable Federal or State labor laws:
 - (a) To set goals, in conference with the Human Resources Director, for each job category or division of the work force used in the completion of the City work;
 - (b) To provide periodic reports concerning the progress the contractor has made in meeting the affirmative action goals it has agreed to;

- (c) To permit the Director access to all books, records and accounts pertaining to its employment practices for the purpose of determining compliance with the affirmative action requirements.
- (5) The Director shall monitor the compliance of each contractor with the nondiscrimination provisions of each contract. The Director shall develop procedures and regulations consistent with the administrative policy adopted by the City Administrator for notice and enforcement of non-compliance. Such procedures and regulations shall include a provision for the posting of contractors not in compliance.
- (6) All City contracts shall provide further that breach of the obligation not to discriminate shall be a material breach of the contract for which the City shall be entitled, at its option, to do any or all of the following:
 - (a) To cancel, terminate, or suspend the contract in whole or part and/or refuse to make any required periodic payments under the contract;
 - (b) Declare the contractor ineligible for the award of any future contracts with the City for a specified length of time;
 - (c) To recover liquidated damages of a specified sum, said sum to be that percentage of the labor expenditure for the time period involved which would have accrued to minority group members had the affirmative action not been breached;
 - (d) Impose for each day of non-compliance, liquidated damages of a specified sum, based upon the following schedule:

Contract Amount	Assessed Damages Per Day of Non-Compliance
\$ 10,000 - 24,999	\$ 25.00
25,000 - 99,999	50.00
100,000 - 199,999	100.00
200,000 - 499,999	150.00
500,000 - 1,499,999	200.00
1,500,000 - 2,999,999	250.00
3,000,000 - 4,999,999	300.00
5,000,000 - and above	500.00

- (e) In addition the contractor shall be liable for any costs or expenses incurred by the City of Ann Arbor in obtaining from other sources the work and services to be rendered or performed or the goods or properties to be furnished or delivered to the City under this contract.

APPENDIX B – LIVING WAGE FORMS

**City of Ann Arbor
LIVING WAGE ORDINANCE
DECLARATION OF COMPLIANCE**

The Ann Arbor Living Wage Ordinance (Section 1:811-1:821 of Chapter 23 of Title I of the Code) requires that employers providing services to the City or recipients of grants for financial assistance (in amounts greater than \$10,000 in a twelve-month period of time) pay their employees who are working on the City project or grant, a minimum level of compensation known as the Living Wage. This wage must be paid to the employees for the length of the contract/project.

Companies employing fewer than 5 persons and non-profits employing fewer than 10 persons are exempt from the Ordinance. If this exemption applies to your firm, please check below:

_____ This **company** is exempt due to the fact that we employ or contract with fewer than 5 individuals.

_____ This **non-profit agency** is exempt due to the fact that we employ or contract with fewer than 10 employees.

The Ordinance requires that all contractors/vendors and/or grantees agree to the following terms:

- a) To pay each of its employees performing work on any covered contract or grant with the City, no less than the living wage, which is defined as \$12.17/hour when health care is provided, or no less than \$13.57/hour for those employers that do *not* provide health care. It is understood that the Living Wage will be adjusted each year on April 30, and covered employers will be required to pay the adjusted amount thereafter. The rates stated above include any adjustment for 2012.
- b) Please check the boxes below which apply to your workforce:
 - Employees who are assigned to *any covered* City project or grant will be paid at or above the applicable living wage without health benefits Yes _____ No _____

OR

 - Employees who are assigned to *any covered* City project or grant will be paid at or above the applicable living wage with health benefits Yes _____ No _____
- c) To post a notice approved by the City regarding the Living Wage Ordinance in every work place or other location in which employees or other persons contracting for employment are working.
- d) To provide the City payroll records or other documentation as requested; and,
- e) To permit access to work sites to City representatives for the purposes of monitoring compliance, investigating complaints or non-compliance.

The undersigned authorized representative hereby obligates the contractor/vendor or grantee to the above stated conditions under penalty of perjury and violation of the Ordinance.

Company Name

Address City State Zip

Signature of Authorized Representative

Phone (area code)

Type or Print Name and Title

Email address

Date signed

Questions about this form? Please contact:
Procurement Office City of Ann Arbor Phone: 734/794-6576

CITY OF ANN ARBOR

RATE EFFECTIVE MAY 1, 2012 - ENDING APRIL 30, 2013

\$12.17 per hour

If the employer provides health care benefits*

\$13.57 per hour

If the employer does **NOT** provide health care benefits*

Employers providing services to or for the City of Ann Arbor or recipients of grants or financial assistance from the City of Ann Arbor for a value of more than \$10,000 in a twelve-month period of time must pay those employees performing work on a City of Ann Arbor contract or grant, the above living wage.

ENFORCEMENT

The City of Ann Arbor may recover back wages either administratively or through court action for the employees that have been underpaid in violation of the law. Persons denied payment of the living wage have the right to bring a civil action for damages in addition to any action taken by the City.

Violation of this Ordinance is punishable by fines of not more than \$500/violation plus costs, with each day being considered a separate violation. Additionally, the City of Ann Arbor has the right to modify, terminate, cancel or suspend a contract in the event of a violation of the Ordinance.

* Health Care benefits include those paid for by the employer or making an employer contribution toward the purchase of health care. The employee contribution must not exceed \$.50 an hour for an average work week; and the employer cost or contribution must equal no less than \$1/hr for the average work week.

For Additional Information or to File a Complaint Contact:

Linda Newton, Procurement Officer
734/794-6576 or Lnewton@a2gov.org.

The Law Requires Employers to Display This Poster Where Employees Can Readily See It.

APPENDIX C - CONTRACT COMPLIANCE FORMS

City of Ann Arbor Procurement Office INSTRUCTIONS FOR CONTRACTORS

For Completing CONTRACT COMPLIANCE FORM

City Policy

The “non discrimination in contracts” provision of the City Code, (Chapter 112, Section 9:161) requires contractors/vendors/grantees doing business with the City not to discriminate on the basis of actual or perceived race, color, religion, national origin, sex, age, condition of pregnancy, marital status, physical or mental limitations, source of income, family responsibilities, educational association, sexual orientation, gender identity or HIV status against any of their employees, any City employee working with them, or any applicant for employment. It also requires that the contractors/vendors/grantees include a similar provision in all subcontracts that they execute for City work or programs.

This Ordinance further requires that each prospective contractor/vendor submit employment data to the City showing current total employee breakdown by occupation, race and gender. This allows the Human Rights Office to determine whether or not the contractor/vendor has a workforce that is reflective of the availability of women and under-represented minorities within the contractor’s labor recruitment area (the area where they can reasonably be expected to recruit employees). *This data is provided to the City on the Human Rights Contract Compliance Forms (attached).*

To complete the form:

1) If a company has more than one location, then that company must complete 2 versions of the form.

- **Form #1** should contain the employment data for the **entire corporation**.
- **Form #2** should contain the employment data for those employees:
 - who will be working on-site;
 - in the office responsible for completing the contract; or,
 - in the case of non-profit grantees, those employees working on the project funded by the City grant(s).

2) If the company has only one location, fill out Form #1 only.

3) Complete all data in the upper section of the form including the name of the person who completes the form and the name of the company/organization’s president.

4) Complete the Employment Data in the remainder of the form. Please be sure to complete all columns including the Total Columns on the far right side of the form, and the Total row and Previous Year Total row at the bottom of the form.

5) Return the completed form(s) to your contact in the City Department for whom you will be conducting the work.

For assistance in completing the form, contact:

Procurement Office of the City of Ann Arbor
(734) 794-6576

If a contractor is determined to be out of compliance, the Procurement Office will work with them to assist them in coming into compliance.

**CITY OF ANN ARBOR HUMAN RIGHTS OFFICE
CONTRACT COMPLIANCE FORM**

Form #1

Entire Organization (Totals for All Locations where applicable)

Name of Company/Organization _____ Date Form Completed _____

Name and Title of Person Completing this Form _____ Name of President _____

Address _____ County _____ Phone # _____
 (Street address) (City) (State) (Zip) (Area Code)

Fax# _____ Email Address _____
 (Area Code)

EMPLOYMENT DATA

Job Categories	Number of Employees (Report employees in only one category)												
	Male						Female						TOTAL COLUMNS A-L
	White	Black or African American	Asian	Hispanic or Latino	Native Hawaiian or Other Pacific Islander	American Indian or Alaska Native	White	Black or African American	Asian	Hispanic or Latino	Native Hawaiian or Other Pacific Islander	American Indian or Alaskan Native	
A	B	C	D	E	F	G	H	I	J	K	L		
Exec/Sr. Level Officials													
Supervisors													
Professionals													
Technicians													
Sales													
Admin. Support													
Craftspeople													
Operatives													
Service Workers													
Laborers/Helper													
Apprentices													
Other													
TOTAL													
PREVIOUS YEAR TOTAL													

**CITY OF ANN ARBOR HUMAN RIGHTS OFFICE
CONTRACT COMPLIANCE FORM**

Form #2

Local Office (Only those employees that will do local or on-site work, if applicable)

Name of Company/Organization _____ Date Form Completed _____

Name and Title of Person Completing this Form _____ Name of President _____

Address _____ County _____ Phone # _____
(Street address) (City) (State) (Zip) (Area Code)

Fax# _____ Email Address _____

(Area Code)

EMPLOYMENT DATA

Job Categories	Number of Employees (Report employees in only one category)												
	Male						Female						
	White	Black or African American	Asian	Hispanic or Latino	Native Hawaiian or Other Pacific Islander	American Indian or Alaska Native	White	Black or African American	Asian	Hispanic or Latino	Native Hawaiian or Other Pacific Islander	American Indian or Alaskan Native	TOTAL COLUMNS A-L
	A	B	C	D	E	F	G	H	I	J	K	L	
Exec/Sr. Level Officials													
Supervisors													
Professionals													
Technicians													
Sales													
Admin. Support													
Craftspeople													
Operatives													
Service Workers													
Laborers/Helper													
Apprentices													
Other													
TOTAL													
PREVIOUS YEAR TOTAL													

**Appendix D
CUB Agreement**

- Effective June 4, 2012-

CITY OF ANN ARBOR RESOLUTION R-12-246
CUB AGREEMENT REQUIREMENT

**NOTICE TO ALL CONTRACTORS AND SUBCONTRACTORS
PERFORMING CONSTRUCTION WORK FOR THE CITY OF ANN
ARBOR ON ANY CITY CONSTRUCTION PROJECT**

Any labor used on City construction projects bid and awarded by the City of Ann Arbor for new construction with a contract amount over \$25,000 must be governed by the current collective bargaining agreement of the appropriate Local Unions of the Washtenaw County Skilled Building Trades Council (SBTC).

All invitations to bid for construction contracts include, as a condition of award, the requirement that all contractors and subcontractors awarded a construction contract for new construction projects where the value of the contract is over \$25,000 execute a CUB agreement with the SBTC. Each contractor and subcontractor at all tiers of a project shall, prior to beginning work on the project, become signatory parties to the respective current collective bargaining agreements of the appropriate Local Unions of the SBTC. Alternately, when no other agreement exists, a Contractor may sign a one-time project agreement for the CUB project, covering that construction project only.

All potential bidders and contractors must contact the current CUB representative, Bart Nickerson at 734-944-5317 (office) or 734-320-2227 (cell) for a complete summary of the procedures and requirements pursuant to the CUB Memorandum of Understanding

**CONTRACTORS SHALL DISPLAY THIS NOTICE WHERE EMPLOYEES CAN
READILY SEE IT.**

Questions Contact

Linda Newton, Procurement Officer
City of Ann Arbor
lnewton@a2gov.org

CITY OF ANN ARBOR PARKS AND RECREATION BLUFFS PARK ENTRY IMPROVEMENTS

BID No. BID NO, FILE No. 1100

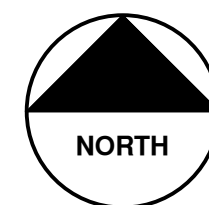

VICINITY MAP

SHEET INDEX

SHEET NO	SHEET TITLE
01	COVER SHEET
02	LEGEND SHEET
03	EXISTING CONDITIONS
04	EROSION CONTROL, DEMO AND GRADING PLAN
05	PLANTING PLAN

S:\Project Management\Design\1100 Bluffs\Plan Production\Primary\1100Cov.dwg Dwg Created: 1-May-12 - _a2 standard bw.stb - Plot Date: 21-Jun-12

	<p>PARKS AND RECREATION CITY OF ANN ARBOR PUBLIC SERVICE 301 EAST HURON STREET, P.O. BOX 8647 ANN ARBOR, MICHIGAN 48107-8647 734-794-6230 www.a2gov.org</p>	
	<p>PREPARED UNDER THE SUPERVISION OF</p> <p>NAME _____ TITLE _____</p> <p>DATE _____</p>	

<p>PARKS AND RECREATION - CITY OF ANN ARBOR</p>	<p>PROJECT DESCRIPTION</p>
	<p>PROJECT DESCRIPTION AND LIMITS</p>
<p>SHEET No.</p>	<p>DRAWING No.</p>
<p>01 TO 05</p>	<p>1100 - 01</p>

PERMITS REQUIRED TO BE OBTAINED BY THE CONTRACTOR PRIOR TO THE BEGINNING OF CONSTRUCTION.

PERMIT	ISSUING AUTHORITY
LANE CLOSURE PERMIT	CITY OF ANN ARBOR PROJECT MANAGEMENT UNIT
"NO PARKING" SIGNS PERMIT	CITY OF ANN ARBOR PROJECT MANAGEMENT UNIT
GRADING/SOIL EROSION & SEDIMENTATION CONTROL PERMIT	CITY OF ANN ARBOR CUSTOMER SERVICE SERVICES UNIT
RIGHT-OF-WAY PERMIT	CITY OF ANN ARBOR PLANNING AND DEVELOPMENT SERVICES UNIT

PERMITS REQUIRED TO BE OBTAINED BY THE CITY OF ANN ARBOR PRIOR TO THE BEGINNING OF CONSTRUCTION.

PERMIT	ISSUING AUTHORITY
M.D.E.Q. WATER MAIN CONSTRUCTION PERMIT	MICHIGAN DEPARTMENT OF ENVIRONMENTAL QUALITY

CONTACT INFORMATION

PUBLIC UTILITIES	OWNER	CONTACT
WATER SEWER STORM	CITY OF ANN ARBOR FIELD OPERATIONS SERVICE UNIT W.R. WHEELER SERVICE CENTER 4251 STONE SCHOOL ROAD ANN ARBOR, MI 48108	DENNY ZINK (734) 794-6350
SIGNS SIGNALS STREET LIGHTS	CITY OF ANN ARBOR FIELD OPERATIONS SERVICE UNIT W.R. WHEELER SERVICE CENTER 4251 STONE SCHOOL ROAD ANN ARBOR, MI 48108	CHUCK FOJTIK (734) 794-6361
PRIVATE UTILITIES	OWNER	CONTACT
GAS	DTE ENERGY 17150 ALLEN ROAD MELVINDALE, MI 48122	JAY WILLIAMS (313) 380-7303
ELECTRIC	DTE ENERGY WESTERN WAYNE SERVICE CENTER 8001 HAGGERTY ROAD BELLEVILLE, MI 48111	CLAY COMBEE (734) 397-4112
CABLE	COMCAST 27800 FRANKLIN ROAD SOUTHFIELD, MI 48034	RON SUTHERLAND (313) 999-8300
PHONE	AT&T 550 S. MAPLE ROAD ANN ARBOR, MI 48103	(734) 996-2135
FIBER OPTIC	MCI 2800 N. GLENFILLE ROAD RICHARDSON, TX 75082	DEAN BOYERS (972) 729-6016

EXISTING LEGEND

	FIRE HYDRANT		WATER MAIN
	GATE VALVE IN BOX		STORM SEWER
	GATE VALVE IN WELL		SANITARY SEWER
	STOP BOX		GAS MAIN
	WATER VAULT		ELECTRICAL OVER HEAD
	WELL		ELECTRICAL UNDER GROUND
	CATCH BASIN (SQ)		BOUNDARY
	CATCH BASIN (RD)		BUILDING
	STORM MANHOLE		CENTERLINE OF DITCH
	NON-CURB CATCH BASIN (SQ)		CENTERLINE/CROWN OF ROAD
	SANITARY MANHOLE		EDGE OF WATER
	CLEAN-OUT		FENCE
	POST		GRAVEL
	PEDESTRIAN SIGNAL		R.O.W.
	SIGN		TREELINE
	HAND HOLE		WETLAND
	ORNAMENTAL LIGHT		TREE (DECIDUOUS)
	FLOOD LIGHT		TREE (CONIFEROUS)
	UNKNOWN MANHOLE		STUMP
	TELEPHONE MANHOLE		SHRUB (DECIDUOUS)
	TELEPHONE RISER		
	GAS VALVE		
	GAS VENT		
	GAS BOX		
	ELECTRICAL RISER		
	TRANSFORMER		
	UTILITY POLE		
	LAMP POLE		
	GUY ANCHOR		
	GUY POLE		
	MONITORING WELL		
	MAILBOX		
	SOIL BORING		
	TRAVERSE POINT		
	BENCH MARK		
	IRON PIPE		
	MON BOX		

PROPOSED LEGEND

	HYDRANT (PLAN)		BUILDING
	WATER GATE WELL		CENTERLINE OF DITCH
	REDUCER		CENTERLINE OF ROAD
	WATER GATE VALVE		FENCE
	WATER STOP BOX		SILT FENCE
	WATER VAULT		LOT/UNIT
	INLET		STAGE LINE
	DOUBLE INLET		CURB
	INLET JUNCTION CHAMBER		TEMPORARY GRADING PERMIT
	ROUND CATCH BASIN		WATER EASMENT
	STORM MANHOLE		STORM EASEMENT
	DRAIN ARROW		SANITARY EASEMENT
	FLARED END SECTION		R.O.W.
	SANITARY MANHOLE		LIMITS OF CONSTRUCTION
	CLEAN-OUT		WATER MAIN
	BARREL		STORM SEWER
	SIGN		SANITARY SEWER
	PUSH BUTTON		DETECTABLE WARNING
			ASPHALT
			CONCRETE
			SIDEWALK
			TREE (DECIDUOUS)
			TREE (CONIFEROUS)

Know what's below.
Call before you dig.

				BY	CHECKED				
				DATE		DATE			
				DRAWN BY	DRAWN				
				ADD DESCRIPTION AND MAKE LAYER PLOT	DESCRIPTION				
				REV.					

PARKS & RECREATION
CITY OF ANN ARBOR

CITY OF ANN ARBOR

PARKS AND RECREATION - CITY OF ANN ARBOR

BLUFFS PARK ENTRY IMPROVEMENTS

###

STA. 00+00 TO STA. 00+00

LEGEND SHEET

SCALE PLAN: N.T.S.

DRAWING No. 1100 - 02

SHEET No. 02 OF 05

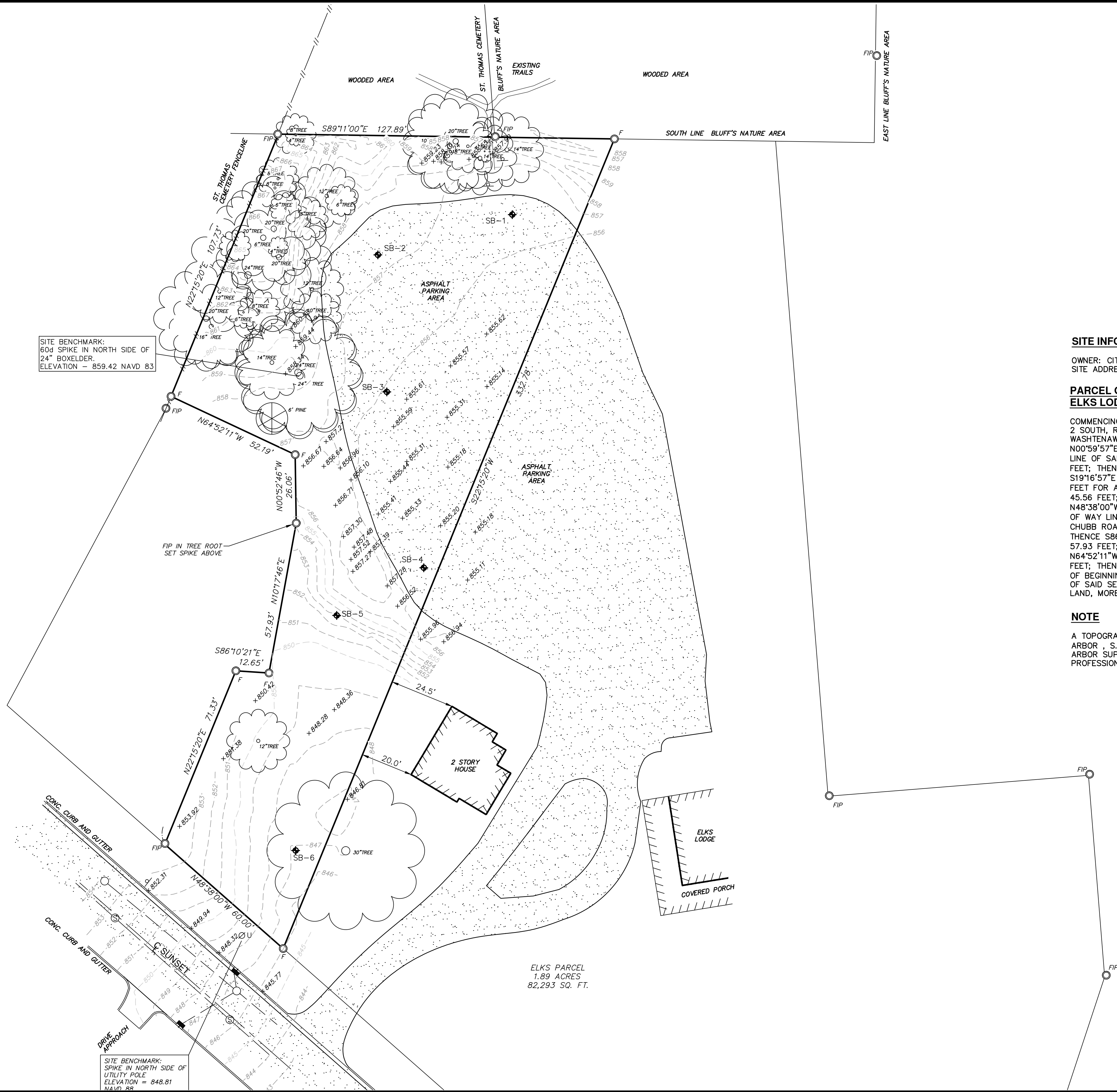

SITE BENCHMARK:
60d SPIKE IN NORTH SIDE OF
24" BOXELDER.
ELEVATION - 859.42 NAVD 83

SITE BENCHMARK:
SPIKE IN NORTH SIDE OF
UTILITY POLE
ELEVATION = 848.81
NAVD 83

ELKS PARCEL
1.89 ACRES
82,293 SQ. FT.

SITE INFORMATION

OWNER: CITY OF ANN ARBOR
SITE ADDRESS: 220 SUNSET ROAD, ANN ARBOR

PARCEL OF LAND TRANSFERRED FROM THE ELKS LODGE TO THE CITY OF ANN ARBOR

COMMENCING AT THE CENTER OF SECTION 20, TOWNSHIP 2 SOUTH, RANGE 6 EAST, CITY OF ANN ARBOR, WASHTENAW COUNTY, STATE OF MICHIGAN; THENCE N00°59'57"E 27.97 FEET ALONG THE NORTH-SOUTH 1/4 LINE OF SAID SECTION; THENCE S79°10'22"E 401.84 FEET; THENCE S66°28'28"E 253.92 FEET; THENCE S19°16'57"E 264.59 FEET; THENCE S04°21'04"E 273.57 FEET FOR A PLACE OF BEGINNING; THENCE S89°11'00"E 45.56 FEET; THENCE S22°15'20"W 332.78 FEET; THENCE N48°38'00"W 60.00 FEET ALONG THE NORTHERLY RIGHT OF WAY LINE OF SUNSET ROAD (FORMERLY CALLED CHUBB ROAD); THENCE N22°15'20"E 71.33 FEET; THENCE S86°10'21"E 12.65 FEET; THENCE N10°17'46"E 57.93 FEET; THENCE N00°52'46"W 26.06 FEET; THENCE N64°52'11"W 52.19 FEET; THENCE N22°15'20"E 107.73 FEET; THENCE S89°11'00"E 82.33 FEET TO THE PLACE OF BEGINNING, BEING A PART OF THE SOUTHEAST 1/4 OF SAID SECTION 20 AND CONTAINING 0.57 ACRES OF LAND, MORE OR LESS.

NOTE

A TOPOGRAPHICAL SURVEY FOR THE CITY OF ANN ARBOR, S.E. 1/4, SECTION 20, T2S, R6E, CITY OF ANN ARBOR SUPPLIED BY: ARBOR LAND CONSULTANTS, INC. PROFESSIONAL LAND SURVEYORS

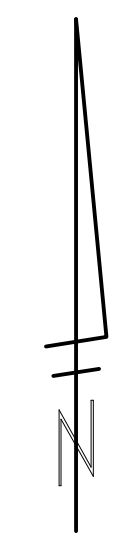

PARKS AND RECREATION - CITY OF ANN ARBOR

BLUFFS PARK ENTRY IMPROVEMENTS

SCALE PLAN: 1" = 20'
PROFILE: 1" = 4'

DRAWING No. 1100 - 03

SHEET No. 03 OF 05

EXISTING CONDITIONS

REV.	DESCRIPTION	DATE	BY	CHECKED
00	ADD DESCRIPTION AN MAKE LAYER PLOT			

811
Know what's below.
Call before you dig.

Parks & Recreation
CITY OF ANN ARBOR

CITY OF ANN ARBOR
MICHIGAN

S:\Project Management\Design\1100 Bluffs\Plan Production\Primary\1100Grading.dwg Dwg Created: 2-May-12 -- a2 standard bw.stb -- Plot Date: 21-Jun-12

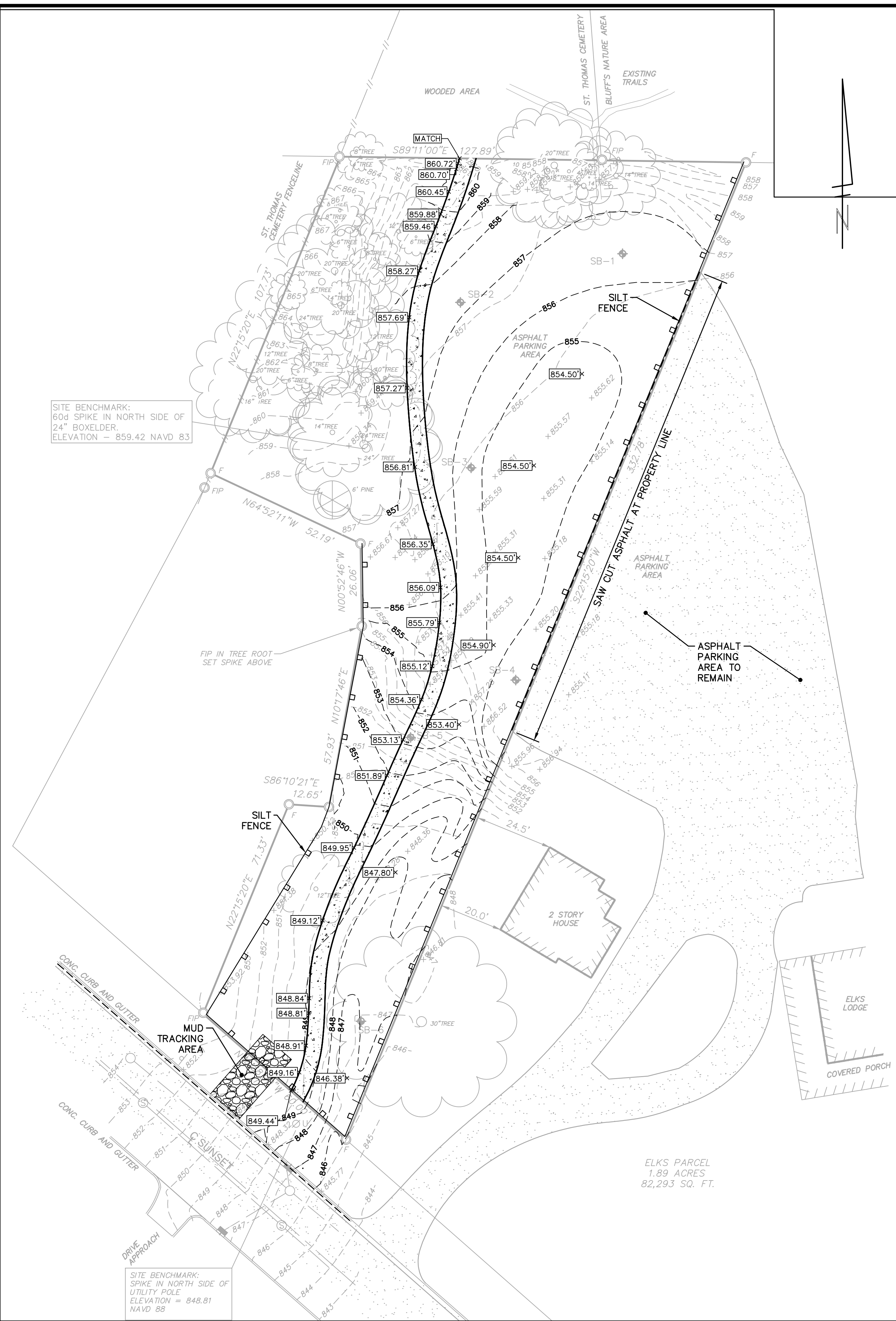

SITE BENCHMARK:
60d SPIKE IN NORTH SIDE OF
24" BOXELDER.
ELEVATION = 859.42 NAVD 83

SITE BENCHMARK:
SPIKE IN NORTH SIDE OF
UTILITY POLE
ELEVATION = 848.81
NAVD 88

ELKS PARCEL
1.89 ACRES
82,293 SQ. FT.

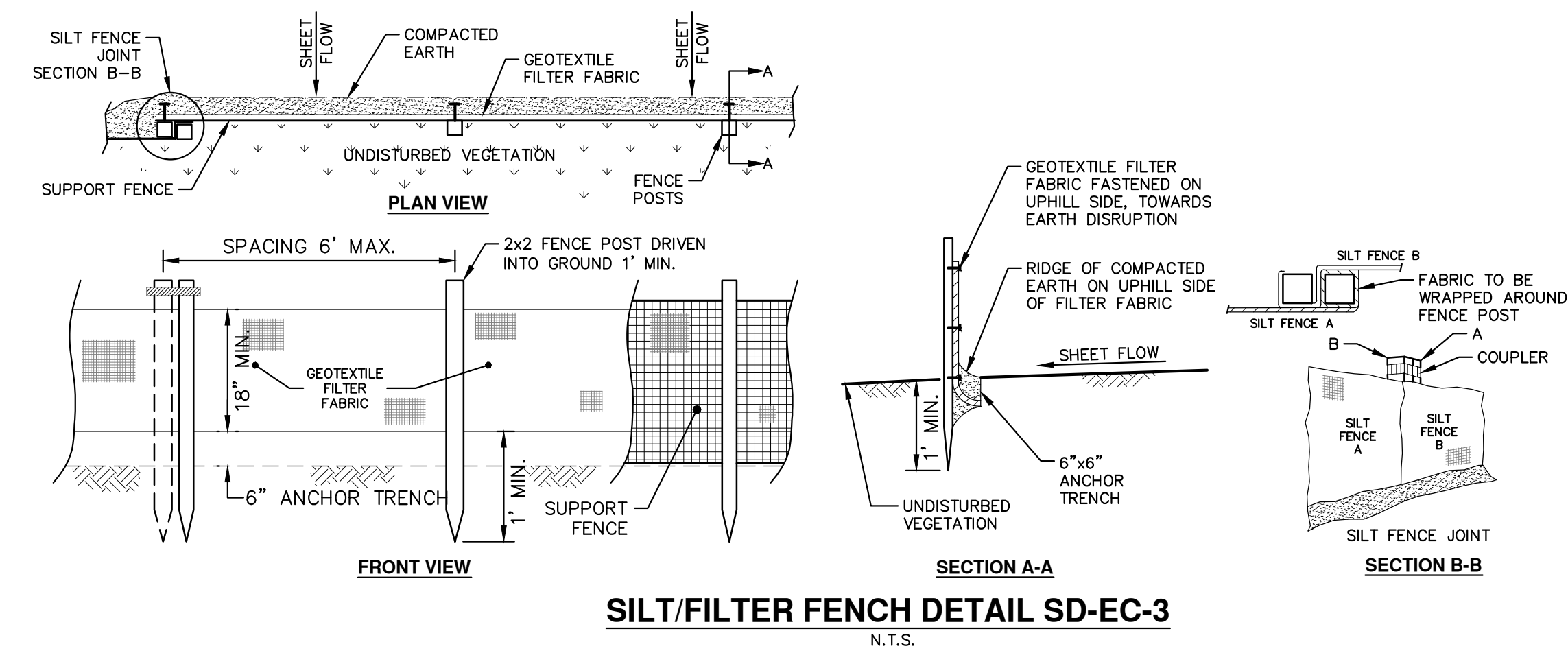

SILT/FILTER FENCE DETAIL SD-EC-3
N.T.S.

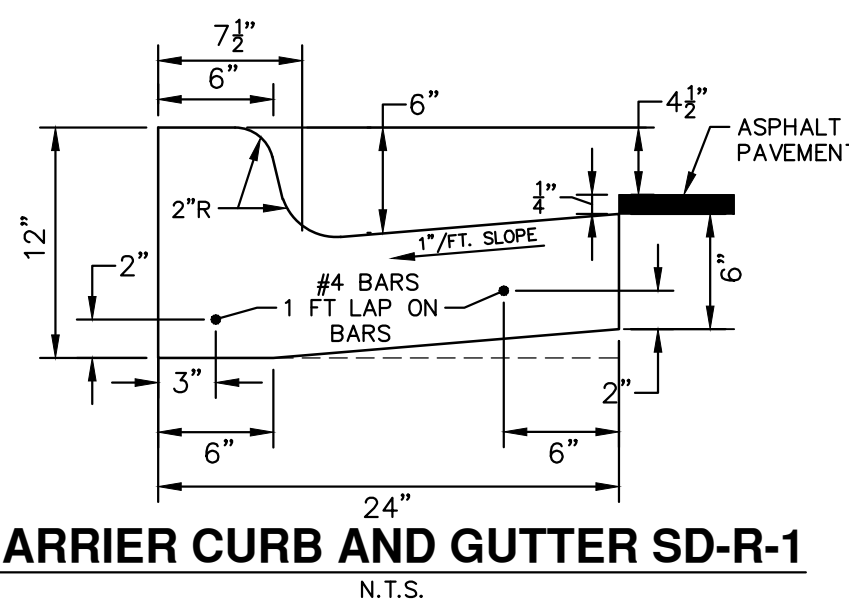

BARRIER CURB AND GUTTER SD-R-1
N.T.S.

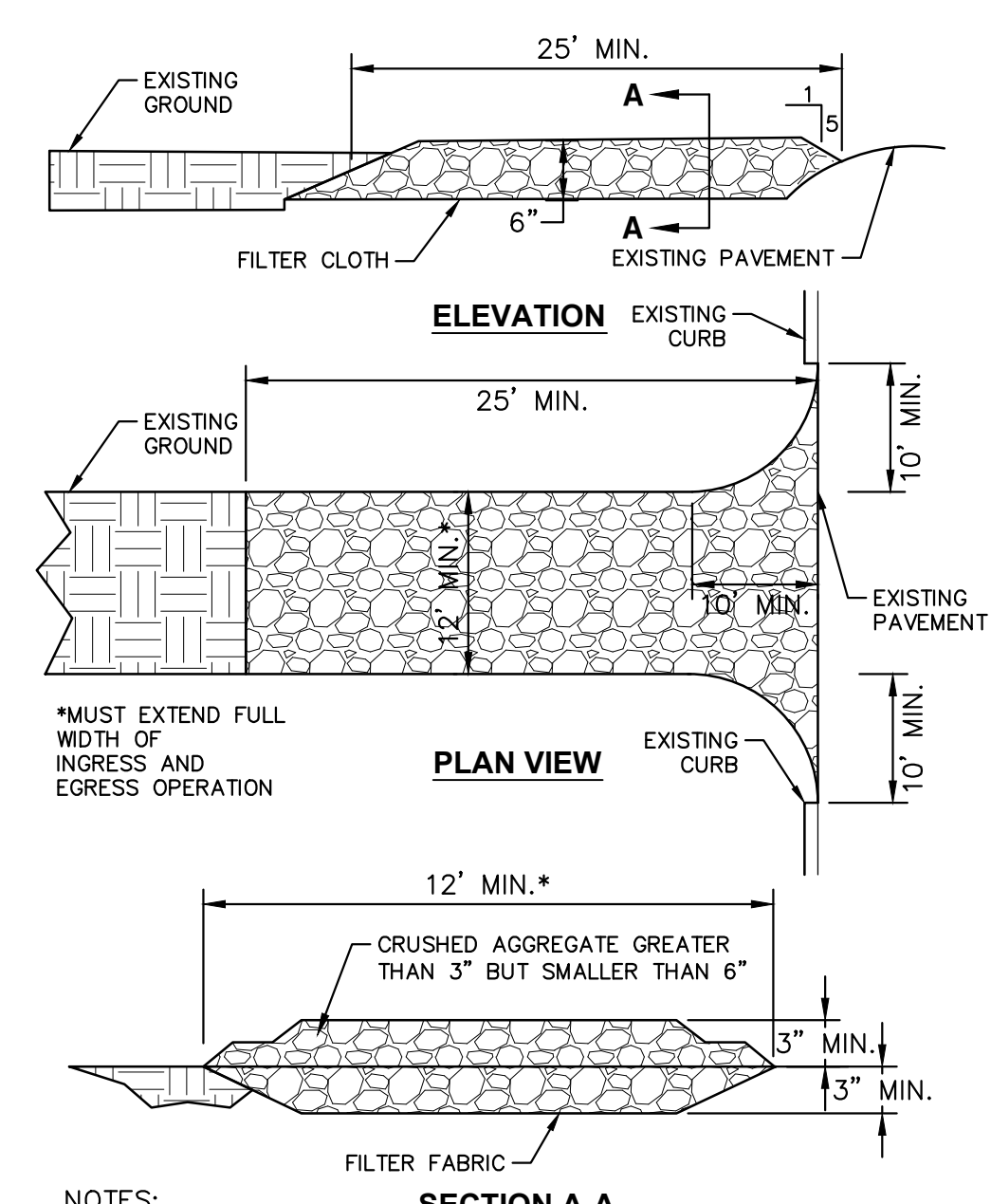

MUD-TRACKING MAT
N.T.S.

GRAVEL PATHWAY
N.T.S.

- SOIL EROSION CONTROL NOTES**
- SILT FENCE TO BE INSTALLED ON ENTIRE EAST SIDE OF PROPERTY, AND ALONG SUNSET. SILT FENCE MUST BE 18" MIN. HEIGHT
 - THE SOIL IN THE REGION CONSISTS PRIMARILY OF MATHERTON SANDY LOAM, FOX SANDY LOAM, NAPPANEE SILTY CLAY LOAM AND HOYTVILLE SILTY CLAY LOAM.
 - EROSION CONTROL AND MUD TRACKING SHALL BE MAINTAINED DURING CONSTRUCTION OPERATIONS AND UNTIL SITE IS STABILIZED.
 - ALL PROTECTIVE FENCING AND INLET FILTERS ARE TO BE INSTALLED ACCORDING TO THE CITY OF ANN ARBOR PUBLIC SERVICES DEPARTMENT STANDARD SPECIFICATIONS.
 - MUD TRACKING SURFACE, MUST BE LONG AND WIDE ENOUGH TO PREVENT VEHICLES ENTERING AND EXISTING THE SITE FROM TRACKING SOILS INTO THE STREET. ANY SOILS TRACKED INTO THE STREET MUST BE REMOVED IMMEDIATELY FOLLOWING EACH TRACKING OCCURRENCE.
 - SHOULD CONSTRUCTION DISCONTINUE, THE COST OF PROTECTING ALL EXPOSED SOIL SURFACES IS ESTIMATED TO BE \$10,000.
 - AS ALL EROSION CONTROL SYSTEMS ARE TEMPORARY, NO MAINTENANCE AGREEMENT IS NECESSARY.
 - LANDMARK TREES ARE TO BE PROTECTED WITH THE PROTECTIVE FENCING.

- DEMO NOTES**
- ASPHALT PARKING LOT TO BE SAWCUT AT PROPERTY LINE, WITH 8" OF ASPHALT AND BASE TO BE REMOVED AND DISPOSED OF OFF SITE.
 - DEBRIS PILES AND MISCELLANEOUS DEBRIS AS NOTED ON PLANS, MARKED IN FIELD, AND DISCUSSED ON SITE TO BE REMOVED AND DISPOSED OF.
 - DURING GRADING OPERATIONS, ANY DEBRIS UNCOVERED SHALL BE REMOVED FROM SITE, INCLUDING ON SLOPE BETWEEN LOW AND HIGH AREAS OF SITE.
 - ALL TREE STUMPS ON SITE TO BE REMOVED. IN AREAS WHERE GRADE IS NOT TO CHANGE, STUMPS SHALL EITHER BE GROUND, OR IF REMOVED MANUALLY, THE VOID REMAINING SHALL BE BACKFILLED WITH CLEAN FILL, AND 4" CLEAN TOPSOIL.

- CONSTRUCTION NOTES**
- ALL DISTURBED AREA SHALL BE BACKFILLED WITH 4" CLEAN FILL AND 4" TOPSOIL, WHICH SHALL BE APPROVED BY CITY PROJECT MANAGER PRIOR TO SPREADING.
 - PLANTS SHALL BE MULCHED IN GROUPS WHERE SHOWN ON PLAN WITH 3" CEDAR MULCH.
 - CONTRACTOR SHALL NOT PARK VEHICLES UNDER DRIPLINE OF ANY TREES. THE LOCATION AND DEPTH OF ALL EXISTING UTILITIES AND SERVICE LEADS ARE TO BE FIELD VERIFIED BY THE CONTRACTOR PRIOR TO CONSTRUCTION.
 - LOCATION AND DEPTH OF UTILITIES AS DEPICTED ON THE PLANS IS APPROXIMATE AND SHOWN ACCORDING TO THE BEST INFORMATION AVAILABLE. IT IS CONTRACTOR'S RESPONSIBILITY TO EXCAVATE AHEAD AND ADJUST DEPTH OF CONFLICT UTILITIES ACCORDINGLY. ANY DAMAGE TO UTILITIES IS THE CONTRACTOR'S RESPONSIBILITY TO AVOID AND/OR REPAIR AS NECESSARY.
 - WHERE STREET CURBS ARE UNDERMINED DUE TO CONSTRUCTION ACTIVITIES, THEY SHALL BE REMOVED AND REPLACED AS DIRECTED BY THE ENGINEER.
 - THE CONTRACTOR SHALL BE RESPONSIBLE FOR THE CONTINUOUS MAINTENANCE OF THE TEMPORARY ROAD SURFACE AND SOIL EROSION CONTROL MEASURES WITHIN THE CONSTRUCTION AREA UNTIL THE FULL COMPLETION OF THE PROJECT. THIS WORK SHALL BE INCLUDED IN THE ITEM OF WORK "GENERAL CONDITIONS".
 - ALL CURB, SIDEWALK, DRIVEWAY APPROACH REMOVALS SHALL BE APPROVED BY ENGINEER BEFORE THE WORK IS DONE.
 - THE LOCATION OF MATERIAL STOCK PILES AND ON-SITE STAGING AREAS TO BE APPROVED BY THE ENGINEER.
 - PAYMENT FOR DRAINAGE STRUCTURE SUMPS, WHERE SPECIFIED, SHALL BE INCLUDED IN THE PAYMENT FOR THE VARIOUS DRAINAGE STRUCTURE SIZES AND OR TYPES.
 - EXISTING STREET NAME, GUIDE, AND REGULATORY SIGNS, AND MAILBOXES WHICH CONFLICT WITH THE PROPOSED CONSTRUCTION SHALL BE REMOVED PRIOR TO CONSTRUCTION, STORED IN A MANNER WHICH WILL PREVENT DAMAGE, AND RE-SET IN LOCATIONS AS DIRECTED BY THE ENGINEER. THIS WORK WILL NOT BE PAID FOR SEPARATELY, BUT SHALL BE INCLUDED IN "MACHINE GRADING, MODIFIED"

DATE	DATE	DATE	DATE	DATE	DATE	DATE	DATE	DATE	DATE
BY	BY	BY	BY	BY	BY	BY	BY	BY	BY
CHECKED	CHECKED	CHECKED	CHECKED	CHECKED	CHECKED	CHECKED	CHECKED	CHECKED	CHECKED
DESCRIPTION	DESCRIPTION	DESCRIPTION	DESCRIPTION	DESCRIPTION	DESCRIPTION	DESCRIPTION	DESCRIPTION	DESCRIPTION	DESCRIPTION
REV.	REV.	REV.	REV.	REV.	REV.	REV.	REV.	REV.	REV.

PARKS AND RECREATION - CITY OF ANN ARBOR

BLUFFS PARK ENTRY IMPROVEMENTS

EROSION CONTROL, DEMO AND GRADING PLAN

SCALE PLAN: 1" = 20'

PROFILE: 1" = 4'

DRAWING No. **1100 - 04**

SHEET No. **04 OF 05**

S:\Project Management\Design\1100 Bluffs\Plan Production\Primary\1100Pint.dwg Dwg Created: 2-May-12 -- a2 standard bw.stb - Plot Date: 21-Jun-12

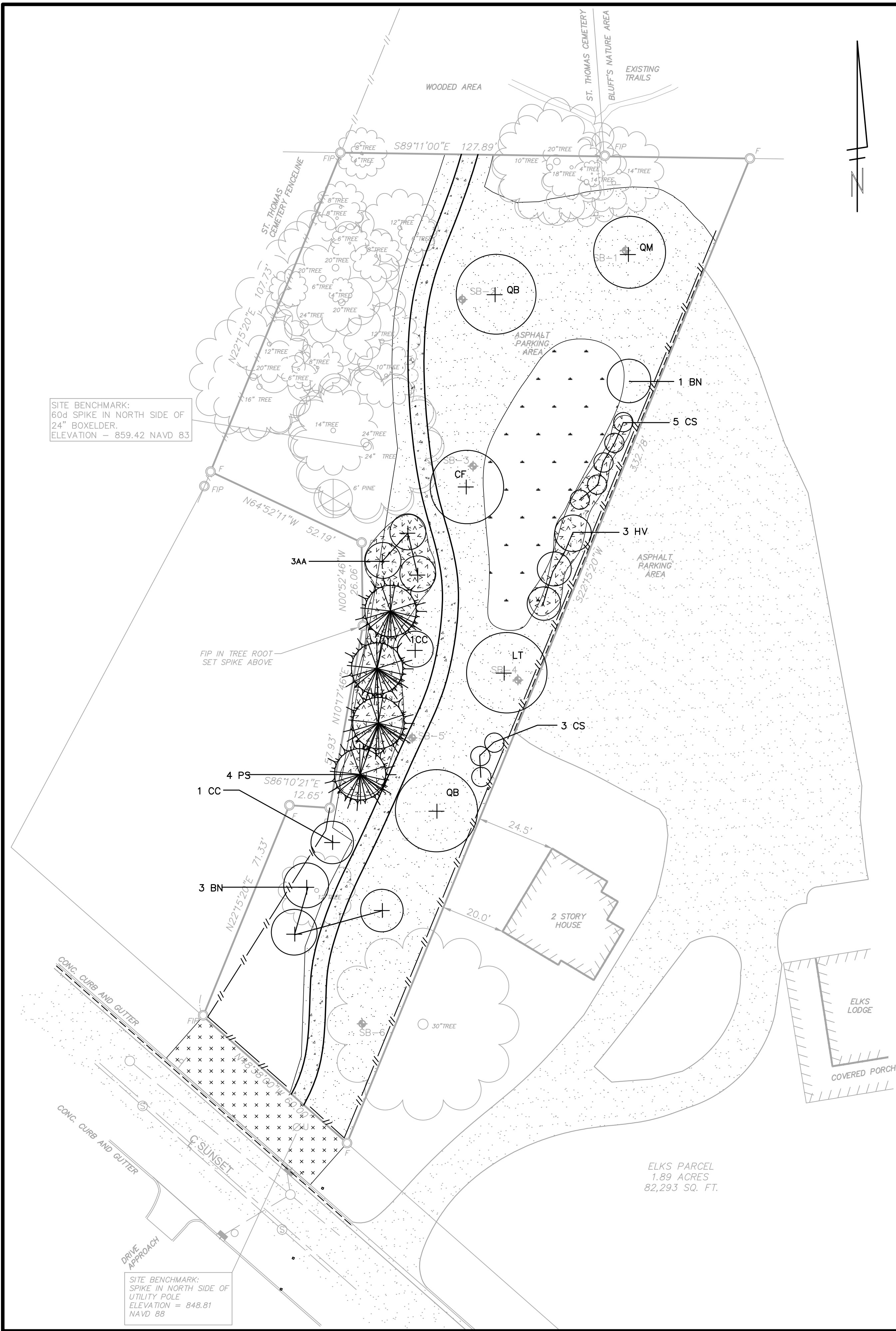

QUANTITY	SCIENTIFIC NAME	COMMON NAME	ABBREVIATION
1	QUERCUS MACROCARPA	BUR OAK	QM
2	QUERCUS BICOLOR	SWAMP WHITE OAK	QB
8	CORNUS STOLONIFERA	RED-OSIER DOGWOOD	CS
1	LIRIODENDRON TULIPIFERA	TULIP TREE	LT
2	CERCIS CANADENSIS	REDBUD	CC
3	AMELANCHIER ARBOREA	DOWNY SERVICEBERRY	AA
4	PINUS STROBUS	WHITE PINE	PS
1	CORNUS FLORIDA	FLOWERING DOGWOOD	CF
3	HAMMELIS VIRGINIANA	COMMON WITCHHAZEL	HV
3	BETULA NIGRA	RIVER BIRCH	BN

- UPLAND NATIVE SEED MIX 0.30AC
- WET-MESIC PLANTING MIX 0.05AC
- GRASS SEED MIX 0.02 AC
- MULCH BED 22 CY

LANDSCAPING NOTES

- PLANTS SHALL BE MULCHED IN GROUPS WHERE SHOWN ON PLAN WITH 3" CEDAR MULCH.
- CONTRACTOR SHALL NOT PARK VEHICLES UNDER DRIPLINE OF ANY TREES.
- WOOD FENCE, TO RUN LENGTH OF EAST PROPERTY LINE, ALONG ENTIRE FRONTAGE, AND UP TO CORNER OF FENCE ON WEST SIDE.

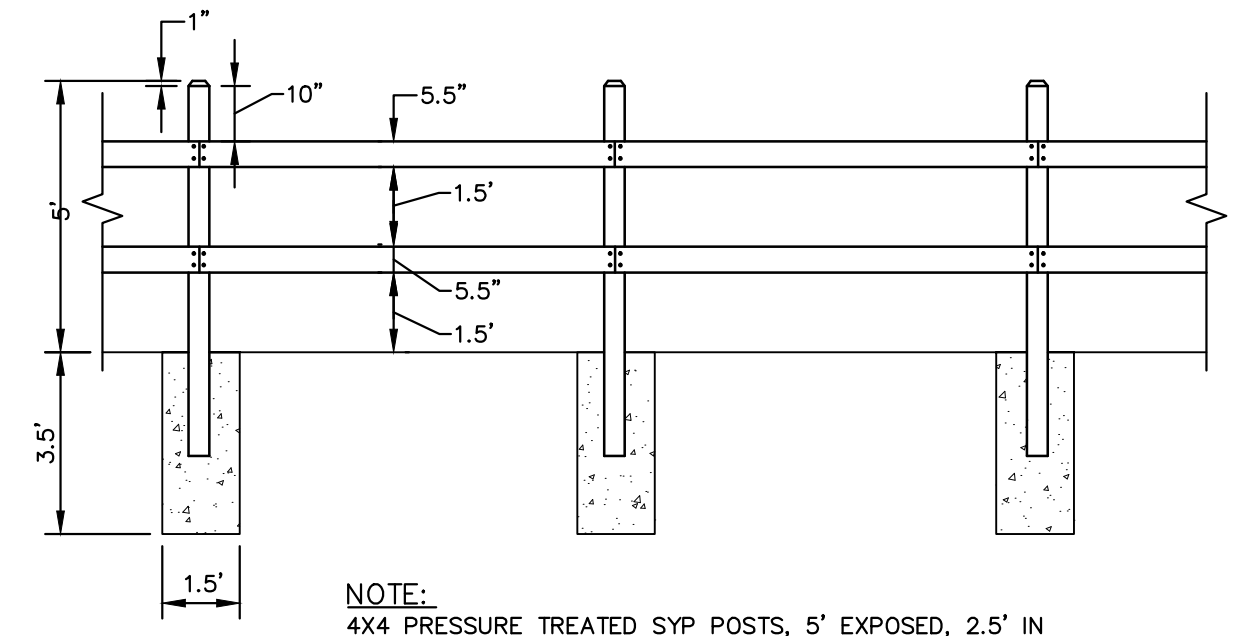

NOTE:
4X4 PRESSURE TREATED SYP POSTS, 5' EXPOSED, 2.5" IN FOOTING. CHAMFER TOP EDGES OF POST. 2 X 6 PRESSURE TREATED SYP RAILS, LAG BOLTED INTO POSTS, 4 PER POST. CONCRETE FOOTING, 1.5' DIAMETER, 3'6" DEPTH

WOOD FENCE DETAIL

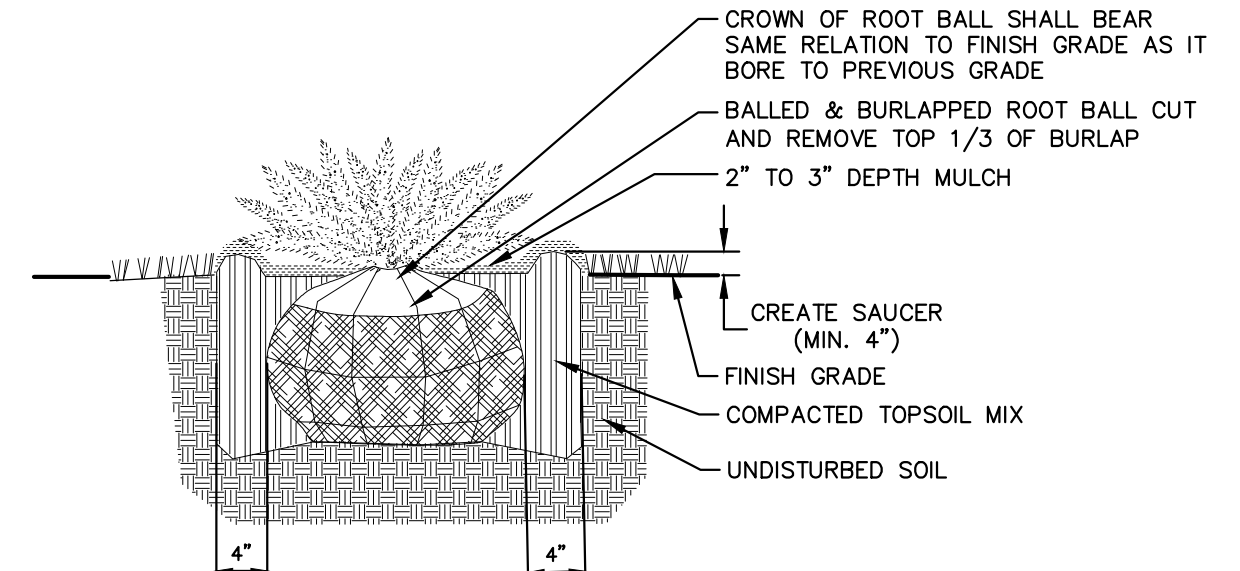

- NOTES:
- DO NOT ALLOW AIR POCKETS TO FORM WHEN BACKFILLING
 - WATER SHRUB THOROUGHLY SUBSEQUENT TO INSTALLATION

SHRUB PLANTING DETAIL

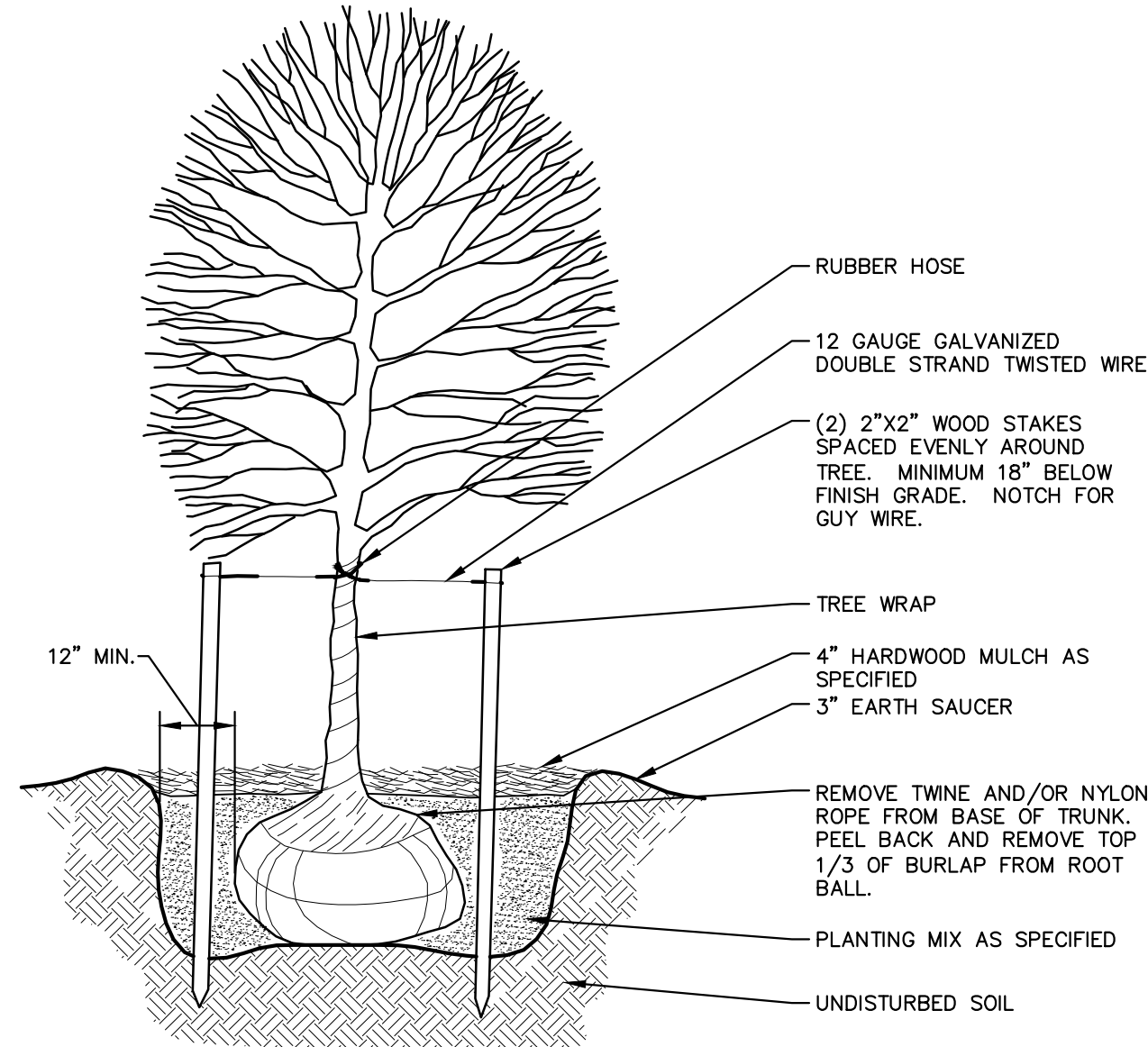

- NOTE:
- DO NOT CUT LEADER. 20% OF BRANCHES MAY BE PRUNED IF NECESSARY, BUT NATURAL SHAPE OF TREE MUST BE RETAINED. TREE TO BE STAKED ONLY IF DIRECTED BY LANDSCAPE ARCHITECT.
 - TREE SHALL BEAR SAME RELATION TO FINISH GRADE AS IT BORE TO PREVIOUSLY EXISTING GRADE

TREE PLANTING DETAIL

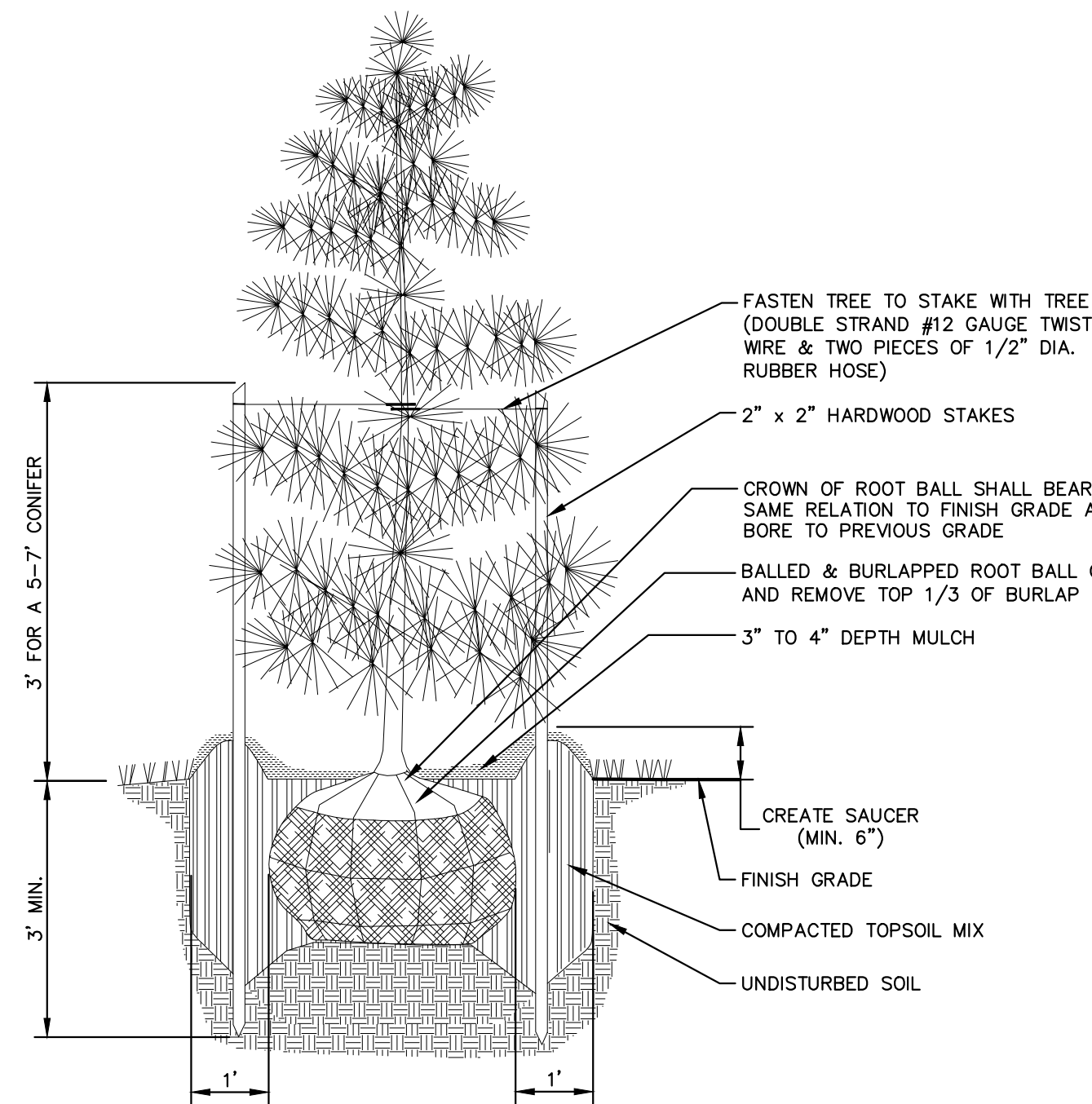

- NOTES:
- DO NOT ALLOW AIR POCKETS TO FORM WHEN BACKFILLING
 - DO NOT DAMAGE MAIN ROOTS OR DESTROY ROOT BALL WHEN INSTALLING TREE STAKE
 - REMOVE TREE RINGS, TREE WRAP AND STAKES TWO YEARS AFTER INSTALLATION
 - WATER TREE THOROUGHLY SUBSEQUENT TO INSTALLATION

CONIFEROUS TREE PLANTING DETAIL BALLED AND BURLAPPED

Know what's below. Call before you dig.

NO.	ADD DESCRIPTION	AN	MAKE LAYER	PLOT	DATE	DATE	BY	CHECKED

PARKS & RECREATION
CITY OF ANN ARBOR

CITY OF ANN ARBOR

PARKS AND RECREATION - CITY OF ANN ARBOR

BLUFFS PARK ENTRY IMPROVEMENTS

SCALE PLAN: 1" = 20' PROFILE: 1" = 4'

DRAWING No. **1100 - 05**

SHEET No. **05 OF 05**