



15200 Century Drive | P.O. Box 217 | Dearborn, MI 48121 | phone 800-837-8020 | fax 313-336-0294 | www.appliedhandling.com

Mike Kennedy  
 Ann Arbor Fire Station # 1  
 111 North Fifth Ave  
 Ann Arbor, MI 48104  
 734-794-6960

Thursday, May 6, 2021

Reference Job:  
 OH Sectional Doors - REV 1

<u>Product Description</u>	<u>Qty</u>	<u>Unit Price</u>	<u>Extended Price</u>
<b>Raynor Insulated Sectional Overhead Door</b>	<b>1</b>	<b>\$36,825.35</b>	<b>\$36,825.35</b>
<ul style="list-style-type: none"> <li>● Raynor are constructed of steel, polyurethane, and steel sandwich type construction, with thermal break and calculated materials "R"-value of 18.3 in accordance to industry guidelines. The exterior skin is hot-dipped G-60 galvanized steel, .022" minimum embossing, factory-finished with baked-on polyester primer and Red Exterior / White Interior finish coats with non-repeating random stucco texture and 1/4" wide pinstriping.</li> <li>● Interior skins are hot-dipped, galvanized steel, factory finished with polyester primer and white finish coat. Interior skin shall have two 1-3/4" roll formed integral struts sealed with polypropylene rib caps per section.</li> <li>● Ends shall be sealed with 18 gauge hot-dipped galvanized steel full height end caps.</li> <li>● Cavity shall be filled with formed-in-placed CFC free polyurethane core separated by a factory extruded thermal break.</li> <li>● Track design shall be, high lift. Vertical mounting angle shall be G-60 galvanized. Track size is 2". Vertical track shall be graduated to provide wedge type weathertight closing with continuous angle mounting for steel or wood jambs, and shall be fully adjustable to seal door at jambs.</li> <li>● Hinges and brackets shall be made from hot-dipped, galvanized steel. Track roller are cased hardened inner steel races with 10 ball 2" rollers. All factory authorized attachments shall be made at locations indicated and reinforced with back up plates.</li> <li>● Counterbalance springs shall be torsion type, low stress, helical wound, oil tempered spring wire provide a minimum 100,000 cycles are recommended for high use doors. Springs are mounted on a continuous steel shaft. Spring fittings and drums made of die cast, high strength aluminum. Pre-formed galvanized steel aircraft cable shall provide a minimum of a 5:1 safety factor.</li> <li>● Locks shall engage the right-hand vertical track and utilize an interior side lock.</li> <li>● Please note that all doors will include track. All doors will be (3) Glass Sections w/ 1/2" Insulated Glass.</li> </ul>			
<b>Manaras Electric Openers</b>	<b>1</b>	<b>\$11,091.96</b>	<b>\$11,091.96</b>
<ul style="list-style-type: none"> <li>(6) OGH-6112 Operators - 1/2 HP</li> <li>(1) OGH-6113 Operator - 3/4 HP</li> <li>(7) Wall Mounting Brackets</li> <li>(14) Sets Photo Eyes - (2) Per Door</li> <li>(14) Single Button Transmitters</li> <li>(1) Special - Open / Close / Stop Master Panel</li> </ul>			
<b>Installation</b>	<b>1</b>	<b>\$19,546.00</b>	<b>\$19,546.00</b>

<b>Freight and Handling</b>	<b>Included</b>
<b>Installation</b>	<b>Included</b>
<b>Contractors Use Tax</b>	<b>Included</b>
<b>Total</b>	<b>\$67,463.31</b>

**Quote Prepared For:**  
Mike Kennedy  
Ann Arbor Fire Station # 1  
111 North Fifth Ave  
Ann Arbor, MI 48104  
734-794-6960

**Please Direct Purchase Order To:**  
Mike Wozniak  
Applied Handling, Inc.  
15200 Century Drive  
Dearborn, MI 48120  
313-336-8020  
313-457-1125 x1225 (direct phone)  
313-220-7851 (cellular phone)  
313-336-0294 (fax)  
MWozniak@appliedhandling.com

#### **OH Sectional Doors - REV 1**

- Freight charges are included. F.O.B. shipping point.
- Freight charges are not included. Freight charges will be collect and the responsibility of the purchaser. F.O.B Shipping Point.
- Above pricing includes installation by factory-trained, non-union technicians.
- Electrical Included: Electrical hook up is included from a properly fused disconnect (*installed and provided by customer*) placed within 10' of the control panel mounting location. This work will include control wiring, conduit, limit switch adjustment and final terminal connections.
- Includes the removal of existing equipment.

#### **Applied Handling, Inc. Standard Terms & Conditions**

**SEND PURCHASE ORDER TO: [mwozniak@appliedhandling.com](mailto:mwozniak@appliedhandling.com)**

**COVID-19 REQUIREMENTS:** This proposal DOES NOT provide for additional project specific, COVID-19 specific, or other health emergency requirements including but not limited to additional PPE, health assessment, decontamination, or designated additional manpower. Any additional requirements must be identified in writing prior and presented to Applied Handling for review. Any additional costs for additional equipment, labor, or logistics will be presented thereafter.

**PRICES** quoted are firm for 30 days from the date of the quotation.

**PERMITS OR BONDS** required by any governmental agency will be secured by the Owner.

**DELIVERY** dates specified, if any, are estimates and seller is not liable for any delays.

**All sales subject to approved credit. In some cases pre-payment, down payment or a credit card may be required.**

**PAYMENTS TERMS:** With approved credit, net 30 days from date of invoice. A finance charge of 1.5% per month will be charged for payments not received within 30 days of the invoice date.

#### **INSTALLATION:**

- Installation prices included in this proposal are based on reasonable access to the installation site. We reserve the right to address any additional costs incurred due to poor or obstructed access. These additional costs could be incurred due to interference by other trades or weather related site conditions.
- Installation pricing is based on normal business hours - Monday through Friday.
- Unless otherwise indicated in this proposal, regular hourly rates will be added for fire watch, attending safety orientation or special client requirements.

**EQUIPMENT** being supplied is subject to improvement design/engineering changes without notice or prior approval.

**CANCELLATION CHARGES:** If purchaser cancels this agreement before accepting the merchandise for any reason, the following cancellation charges expressed as a percent of the purchase price will be paid by the purchaser and constitute liquidated damages.

- Standard equipment cancelled at 20% before manufacturing and 50% plus total freight costs after manufacturing. Standard equipment means any equipment described on current price list as available without modifications which can be easily utilized within a reasonable amount of time by a current Applied Handling Customer.
- Special equipment cancelled at 20% before manufacturing, 70% during manufacturing and 100% after manufacturing plus freight costs.

**USE TAXES** - Some projects include a USE tax as required by the Destination State. USE taxes cannot be broken out as a separate item and CANNOT be excluded from the project. Most State

issued tax exemption certificates DO NOT relieve the USE tax obligation. Exemptions MAY apply to Government contracts, Enterprise Zones, or some Health facilities. Consult your tax professional for additional information.

**RETURNS / RESTOCKING CHARGES** – Material returned for credit may be subject to a 20% or greater restocking charge, depending on each manufacturer's policy. Freight or other costs incurred in restocking will be added. Returns of stocked material and those resulting from errors by the seller will not be subject to this charge. Returned material must be new, unused, and able to be resold to qualify for credit. Return of non-stocked items is subject to manufacturer's acceptance.

**WARRANTY and DISCLAIMER** – Applied Handling provides no warranties beyond those offered by the product manufacturer. The seller will provide repaired or replacement material as directed by the manufacturer. No warranty will apply if its products are in any way altered or modified after delivery by seller, installer, purchaser, purchaser's agent, or any other party on direction of purchaser or purchaser's agent. Since Applied Handling cannot control the manner of use of its products after sale, Applied Handling will not be responsible for consequential or indirect damages. Terms of buyers purchase order shall NOT supersede this disclaimer and no warranty, expressed or implied, other than stated herein, shall be honored without an agreement signed by a representative of Applied Handling.

**LITIGATION** – It is agreed that, should litigation become necessary to recover any debt owing, the debtor shall bear the expense of reasonable attorney fees. Any legal action must be brought exclusively in the district of Michigan, southern division in Detroit, Michigan. The parties accept the exclusive personal jurisdiction of these courts and further waive any objection to venue.

**PREVAILING WAGES** - This Agreement is not subject to prevailing wage requirements unless expressly stated and accompanied by required documentation and the applicable wage determination. Additional charges will apply for prevailing wage projects.

**Purchase Price:** \$ \_\_\_\_\_

**Accepted By:** \_\_\_\_\_ **Title:** \_\_\_\_\_

**P.O. #:** \_\_\_\_\_ **Date:** \_\_\_\_\_

**To ensure efficient order processing, please return entire proposal, complete with signature**

ALL SPRING MOUNTING PADS MUST BE FLUSH WITH JAMBS. FIELD CHECK AND VERIFY ALL DETAILS AND DIMENSIONS. JAMBS, HEADER, JAMB EXTENSIONS AND PADS (AS SHOWN) BY OTHER THAN DOOR CONTRACTOR. THIS DRAWING WAS AS COMPLETE AND FACTUAL AS POSSIBLE AT THE TIME IT WAS PRINTED. WE DO HOWEVER, RESERVE THE RIGHT TO MAKE PRODUCT CHANGES IN SPECIFICATIONS AND AVAILABILITY WITHOUT NOTICE.

DRAWING(S) MUST BE APPROVED AND RETURNED TO DOOR DISTRIBUTOR AND FORWARDED TO RAYNOR GARAGE DOORS BEFORE ORDER WILL BE ENTERED INTO PRODUCTION.  
 SHOP DRAWING FAX NUMBER 800/835-5463.

JOB NAME: Ann Arbor Fire Station  
 DISTRIBUTOR: APPLIED HANDLING INC

CONTRACTOR:

ARCHITECT:

CHECKED BY:

DATE: 3/2/2021

LOCATION:

DRAWING NUMBER  
**1921977 A**

SHEET  
**1 OF 4**

DOOR TAG

RAYNOR ORDER NUMBER	QTY	OPENING		ACTUAL		JAMB			MOUNTING	LOCK	
		WIDTH	HEIGHT	WIDTH	HEIGHT	W	S	M			
	6	12' 1"	12' 7"	12' 3"	12' 7 3/4"				X	X	OML
		3683MM	3835.4MM	3733.8 MM	3854.45MM						

**RAYNOR**  
 PROPOSAL  
 DRAWING

- Doors shall be commercial sectional Thermaseal series as manufactured by Raynor Garage Doors.
- Sections — shall be steel sandwich construction, 1 3/4 inches (44.5mm) thick, roll-formed from commercial quality, hot-dipped galvanized steel per ASTM A-653. Sections shall be insulated with polyurethane foam. Exterior skin shall be 25 gauge steel and interior skin shall be 26 gauge steel. Interior and exterior skins shall have pencil grooves and embossed stucco texture with a finish coat of white polyester paint (unless noted). Section end stiles to be 16 gauge galvanized steel. Section shall have an R-value of 16.4. (Calculated characteristics of core material). Interior and exterior skins to be separated by continuous horizontal thermal break and complete weathereased along section joints. Bottom of door to have a flexible U-shaped vinyl seal retained in an aluminum rail.
- Sherwin Williams finish is required. Specify Color # prior to ordering.
- Locking — Omitted.
- Glazing — 1/8 inch (3.2mm) clear insulated DSB glass.
- Fullview Sections — sections shall be made from 6063-T6 extruded aluminum stile and rail construction. Glass enclosed and held in place with self-aligning rigid vinyl glazing retainer. Finish—to match exterior of door sections.
- Tracks — shall be 2 inches (50.8mm), hot-dipped galvanized steel per ASTM A653, fully adjustable for adequate sealing of door to jamb. Horizontal track to be reinforced with a continuous painted steel angle. Angle Mounting — Angle mount to be galvanized steel. Hardware — hinges and brackets shall be galvanized steel. Counterbalance — to be torsion springs consisting of heavy-duty oil-tempered wire on a continuous ball-bearing cross-header shaft. Provided with alcraft-type, galvanized steel lifting cables with minimum factor of 5.
- Spring cycle life to be 100,000

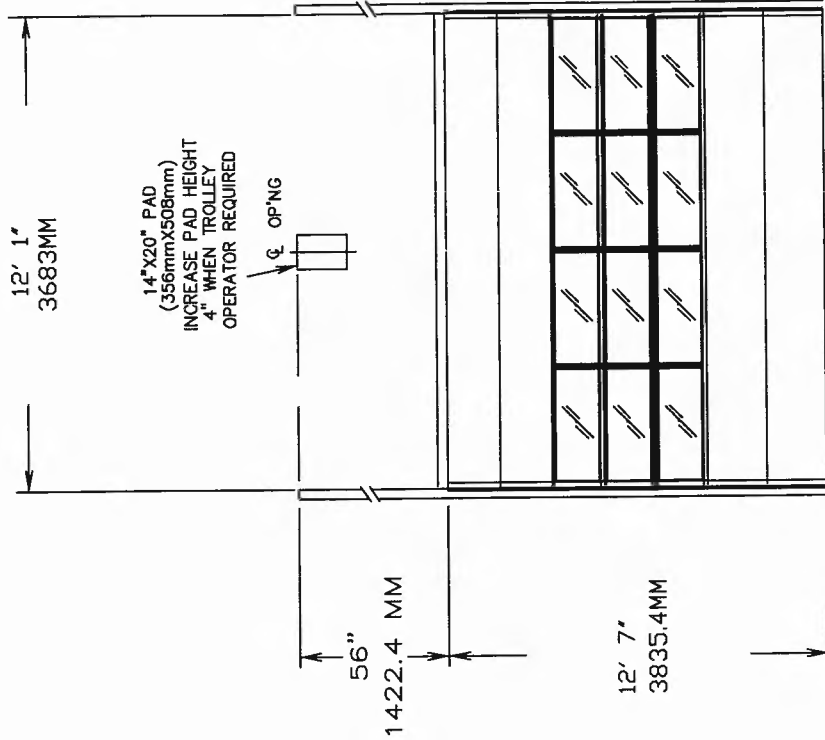

ALL SPRING MOUNTING PADS MUST BE FLUSH WITH JAMBS. FIELD CHECK AND VERIFY ALL DETAILS AND DIMENSIONS: JAMBS; HEADER, JAMB EXTENSIONS AND PADS (AS SHOWN) BY OTHER THAN DOOR CONTRACTOR. THIS DRAWING WAS AS COMPLETE AND FACTUAL AS POSSIBLE AT THE TIME IT WAS PRINTED. WE DO HOWEVER, RESERVE THE RIGHT TO MAKE PRODUCT CHANGES IN SPECIFICATIONS AND AVAILABILITY WITHOUT NOTICE.

DRAWING(S) MUST BE APPROVED AND RETURNED TO DOOR DISTRIBUTOR AND FORWARDED TO RAYNOR GARAGE DOORS BEFORE ORDER WILL BE ENTERED INTO PRODUCTION.  
 SHOP DRAWING FAX NUMBER 800/835-5463.

JOB NAME: Ann Arbor Fire Station  
 DISTRIBUTOR: APPLIED HANDLING INC  
 CONTRACTOR:

LOCATION:

SHEET 2 OF 4  
 DRAWING NUMBER 1921977 A



PROPOSAL DRAWING

ARCHITECT:  
 CHECKED BY:  
 DATE: 3/2/2021

DOOR TAG

RAYNOR ORDER NUMBER	QTY	OPENING		ACTUAL		MODEL	JAMB		MOUNTING	LOCK
		WIDTH	HEIGHT	WIDTH	HEIGHT		W	S		
	6	12' 1"	12' 7"	12' 3"	12' 7 3/4"	TM175	X	X	X	OML
		368.3MM	3835.4MM	3733.8 MM	3854.45MM					

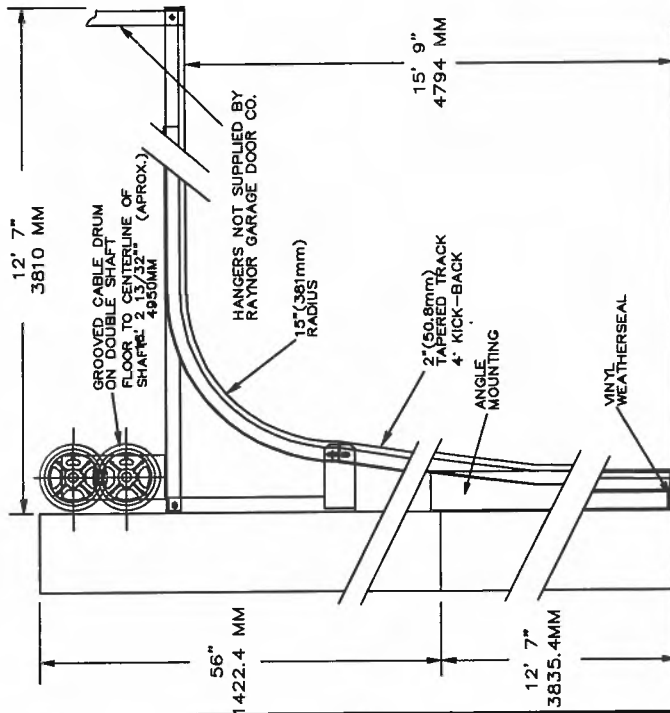

SECTION THRU OPENING

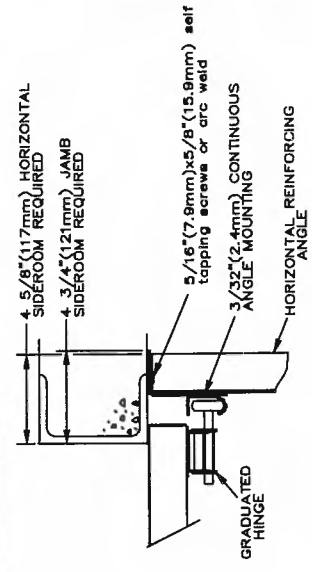

JAMB DETAIL

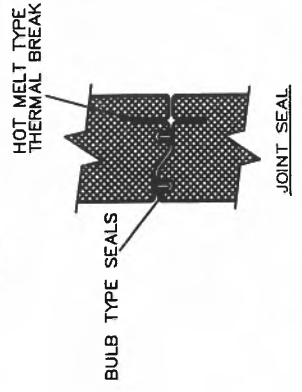

JOB NAME: Ann Arbor Fire Station LOCATION:  
 DISTRIBUTOR: APPLIED HANDLING INC  
 CONTRACTOR:  
 ARCHITECT:  
 CHECKED BY:  
 DATE: 3/2/2021

SHEET 3 OF 4 DRAWING NUMBER 1921977 A  
 RAYNOR. PROPOSAL DRAWING  
 DOOR TAG

ALL SPRING MOUNTING PADS MUST BE FLUSH WITH JAMBS. FIELD CHECK AND VERIFY ALL DETAILS AND DIMENSIONS. JAMBS, HEADER, JAMB EXTENSIONS AND PADS (AS SHOWN) BY OTHER THAN DOOR CONTRACTOR. THIS DRAWING WAS AS COMPLETE AND FACTUAL AS POSSIBLE AT THE TIME IS WAS PRINTED. WE DO HOWEVER, RESERVE THE RIGHT TO MAKE PRODUCT CHANGES IN SPECIFICATIONS AND AVAILABILITY WITHOUT NOTICE.

DRAWING(S) MUST BE APPROVED AND RETURNED TO DOOR DISTRIBUTOR AND FORWARDED TO RAYNOR GARAGE DOORS BEFORE ORDER WILL BE ENTERED INTO PRODUCTION.  
 SHOP DRAWING FAX NUMBER 800/835-5463.

RAYNOR ORDER NUMBER	QTY	OPENING		ACTUAL		JAMB MOUNTING			LOCK	
		WIDTH	HEIGHT	WIDTH	HEIGHT	W	S	M		ANGLE
	1	16' 0"	12' 9"	16' 2"	12' 9 3/4"	X		X		OML
		4876.8MM	3886.2MM	4927.6 MM	3905.25MM					

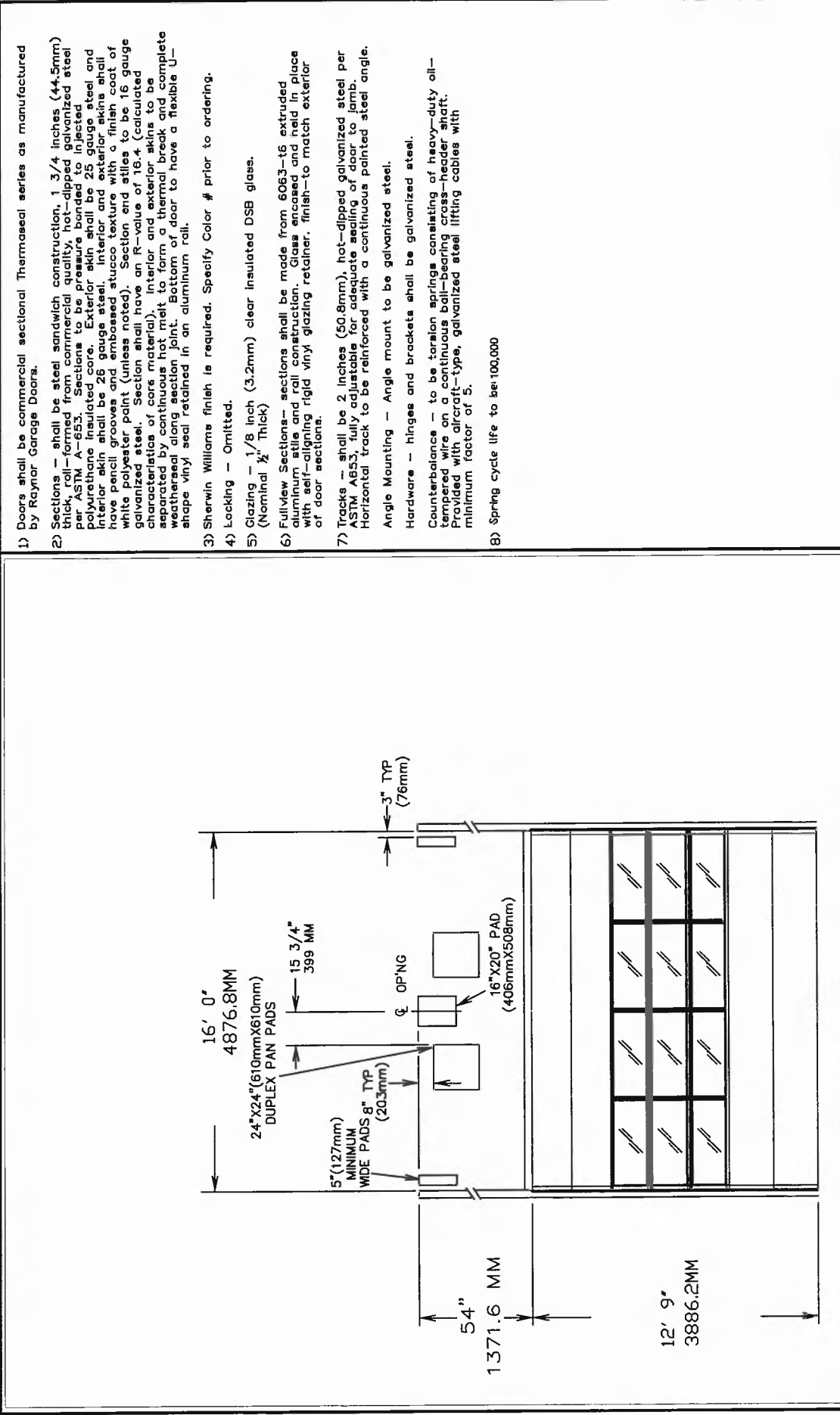

- 1) Doors shall be commercial sectional Thermaseal series as manufactured by Raynor Garage Doors.
- 2) Sections - shall be steel sandwich construction, 1 3/4 inches (44.5mm) thick, roll-formed from commercial quality, hot-dipped galvanized steel per ASTM A-653. Sections to be pressure bonded to injected polyurethane insulated core. Exterior skin shall be 25 gauge steel and interior skin shall be 26 gauge steel. Interior and exterior skins shall have pencil grooves and embossed stucco texture with a finish coat of white polyester paint (unless noted). Section end stiles to be 16 gauge galvanized steel. Section shall have an R-value of 18.4 (calculated characteristics of core material). Interior and exterior skins to be separated by continuous hot melt to form a thermal break and complete weatherseal along section joint. Bottom of door to have a flexible U-shape vinyl seal retained in an aluminum roll.
- 3) Sherwin Williams finish is required. Specify Color # prior to ordering.
- 4) Locking - Omitted.
- 5) Glazing - 1/8 inch (3.2mm) clear insulated DSB glass. (Nominal 1/2" Thick)
- 6) FullView Sections - sections shall be made from 6063-t6 extruded aluminum stile and rail construction. Glass enclosed and held in place with self-aligning rigid vinyl glazing retainer. Finish-to match exterior of door sections.
- 7) Tracks - shall be 2 inches (50.8mm), hot-dipped galvanized steel per ASTM A653, fully adjustable for adequate sealing of door to jamb. Horizontal track to be reinforced with a continuous painted steel angle. Angle Mounting - Angle mount to be galvanized steel. Hardware - hinges and brackets shall be galvanized steel. Counterbalance - to be torsion springs consisting of heavy-duty oil-tempered wire on a continuous ball-bearing cross-header shaft. Provided with aircraft-type, galvanized steel lifting cables with minimum factor of 5.
- 8) Spring cycle life to be 100,000

ALL SPRING MOUNTING PADS MUST BE FLUSH WITH JAMBS. FIELD CHECK AND VERIFY ALL DETAILS AND DIMENSIONS. JAMBS, HEADER, JAMB EXTENSIONS AND PADS (AS SHOWN) BY OTHER THAN DOOR CONTRACTOR. THIS DRAWING WAS AS COMPLETE AND FACTUAL AS POSSIBLE AT THE TIME IT WAS PRINTED. WE DO HOWEVER, RESERVE THE RIGHT TO MAKE PRODUCT CHANGES IN SPECIFICATIONS AND AVAILABILITY WITHOUT NOTICE.

DRAWING(S) MUST BE APPROVED AND RETURNED TO DOOR DISTRIBUTOR AND FORWARDED TO RAYNOR GARAGE DOORS BEFORE ORDER WILL BE ENTERED INTO PRODUCTION.  
SHOP DRAWING FAX NUMBER 800/835-5463.

JOB NAME: Ann Arbor Fire Station LOCATION:  
DISTRIBUTOR: APPLIED HANDLING INC  
CONTRACTOR:

CHECKED BY: SHEET 4 OF 4 DRAWING NUMBER 1921977 A  
DATE: 3/2/2021

RAYNOR  
PROPOSAL DRAWING

RAYNOR ORDER NUMBER	QTY	OPENING		ACTUAL		JAMB MOUNTING			LOCK	
		WIDTH	HEIGHT	WIDTH	HEIGHT	W	S	M		ANGLE
1	1	16' 0"	12' 9"	16'2"	12' 9 3/4"		X		X	OML
		4876.8MM	3886.2MM	4927.6 MM	3905.25MM					

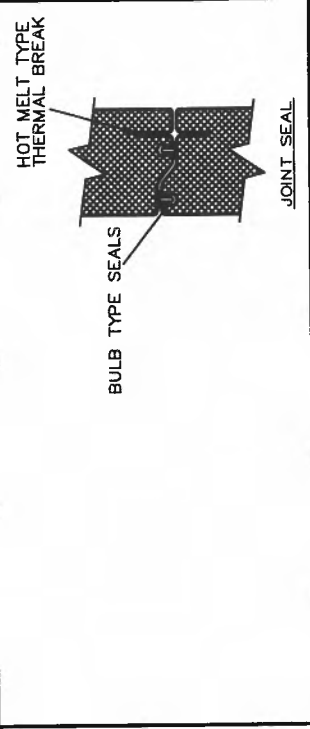
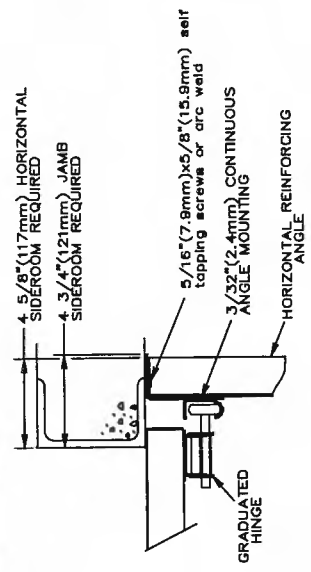
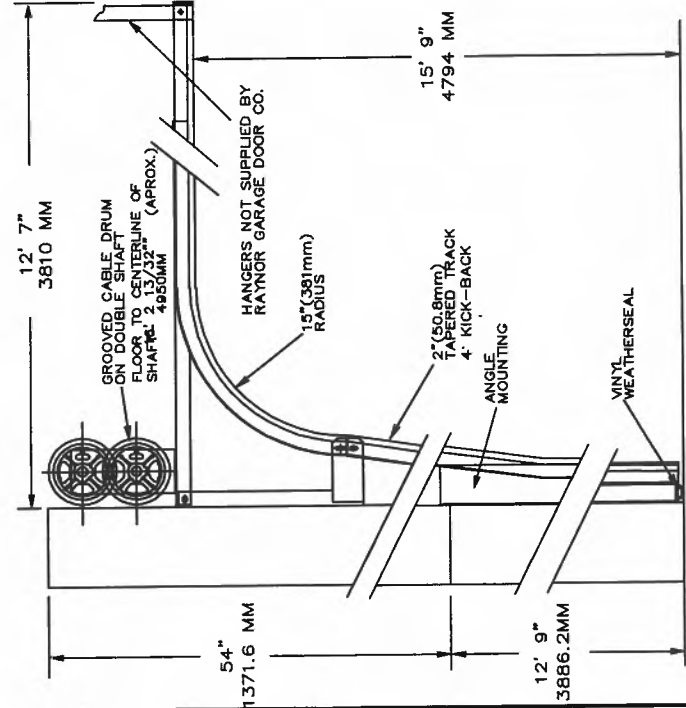

CITY OF ANN ARBOR  
INVITATION TO BID



**NEW GARAGE DOORS AT FIRE STATION 1**

**ITB No. 4681**

**Due Date: May 11, 2021 at 2:00 PM (Local Time)**

Fire Department

Issued By:

City of Ann Arbor  
Procurement Unit  
301 E. Huron Street  
Ann Arbor, MI 48104



## TABLE OF CONTENTS

INSTRUCTIONS TO BIDDERS	3
INVITATION TO BID	8
SPECIFICATIONS	10
BID FORM	12

### **ATTACHMENTS**

<i>City of Ann Arbor Sample Purchase Agreement</i>	
<i>City of Ann Arbor Vendor Conflict of Interest Disclosure Form</i>	
<i>City of Ann Arbor Non-Discrimination Ordinance Declaration Form and Notice</i>	
<i>City of Ann Arbor Living Wage Ordinance Declaration of Compliance and Notice</i>	
<i>City of Ann Arbor Prevailing Wage Declaration of Compliance</i>	

# **INSTRUCTIONS TO BIDDERS**

## **General**

The City of Ann Arbor's Procurement Office is soliciting bids for the purchase and installation of seven new garage doors at Fire Station 1 based on the specifications provided herein. The pricing provided for this ITB shall be firm for one (1) year or upon project completion.

Any Bid which does not conform fully to these instructions may be rejected.

## **Pre-Bid Meeting and Walk Thru**

A recommended pre-bidders meeting and walk thru will be held on May 3, 2021 at 3:00 PM at Fire Station 1, 111 North Fifth Ave, Ann Arbor, MI 48104. The purpose of this meeting is to tour the facility and to answer questions or concerns.

The pre-bid meeting is for information only. Any answers furnished will not be official until verified in writing by the Financial Services Area, Procurement Unit. Answers that change or substantially clarify the bid will be affirmed in writing. Copies will be posted online at the BidNet.com web site and on the City's website.

An agency may not bring more than two persons to the pre-bid meeting. It is strongly suggested that one of the two people in attendance for an agency be the intended primary contact for the agency if the contract is awarded to that agency. Due to COVID, face coverings must be worn, temperatures will be taken, and this will be a standing tour. Access to Fire Station 1 will not be made available at any other time.

## **Preparation of Bids**

Bids should be prepared providing a straight-forward, concise description of the Bidder's ability to meet the requirements of the ITB. Bids shall be written in ink or typewritten. No erasures are permitted. Mistakes may be crossed out and corrected and must be initialed and dated in ink by the person signing the Bid.

Bids must be submitted on the "Bid Forms" provided with each blank properly filled in. If forms are not fully completed it may disqualify the bid. No alternative bid will be considered unless alternative bids are specifically requested. If alternatives are requested, any deviation from the specification must be fully described, in detail on the "Alternate" section of Bid form.

Each person signing the Bid certifies that he/she is the person in the Bidder's firm/organization responsible for the decision as to the fees being offered in the Bid and has not and will not participated in any action contrary to the terms of this provision.

## **Questions or Clarification / Designated City Contacts**

All questions regarding this ITB shall be submitted via email. Emailed questions and inquires will be accepted from any and all prospective Bidders in accordance with the terms and conditions of the ITB.

All questions shall be due on or before **May 4, 2021 @ 3:00 p.m. (local time)** and should be addressed as follows:

Specification/Scope of Work questions emailed to Mike Kennedy, [mkenedy@a2gov.org](mailto:mkenedy@a2gov.org)  
Bid Process and Compliance questions emailed to Colin Spencer, [CSpencer@a2gov.org](mailto:CSpencer@a2gov.org)

Any error, omissions or discrepancies in the specification discovered by a prospective contractor and/or service provider shall be brought to the attention of Colin Spencer at [cspencer@a2gov.org](mailto:cspencer@a2gov.org) after discovery as possible. Further, the contractor and/or service provider shall not be allowed

to take advantage of errors, omissions or discrepancies in the specifications.

## Addenda

If it becomes necessary to revise any part of the ITB, notice of the Addendum will be posted to Michigan Inter-governmental Trade Network (MITN) [www.mitn.info](http://www.mitn.info) and/or City of Ann Arbor web site [www.A2gov.org](http://www.A2gov.org) for all parties to download.

Each Bidder must in its Bid, to avoid any miscommunications, acknowledge all addenda which it has received, but the failure of a Bidder to receive, or acknowledge receipt of; any addenda shall not relieve the Bidder of the responsibility for complying with the terms thereof.

The City will not be bound by oral responses to inquiries or written responses other than written addenda.

## Bid Submission

All Bids are due and must be delivered to the City of Ann Arbor Procurement Unit on or before **May 11, 2021 at 2:00 p.m. (Local time)**. Bids submitted late or via oral, telephonic, telegraphic, electronic mail or facsimile **will not** be considered or accepted.

**Each Bidder must submit one (1) original Bid and one (1) Bid copy in a sealed envelope clearly marked: ITB No. 4681 – New Garage Doors at Fire Station 1.**

### **Bids must be addressed and delivered to:**

City of Ann Arbor  
Procurement Unit,  
c/o Customer Services, 1<sup>st</sup> Floor  
301 East Huron Street  
Ann Arbor, MI 48104

All Bids received on or before the Due Date will be publicly opened and recorded immediately. No immediate decisions are rendered.

**The following forms provided within this ITB Document should be included in submitted bids.**

- **Vendor Conflict of Interest Disclosure Form**
- **City of Ann Arbor Non-Discrimination Ordinance Declaration of Compliance**
- **City of Ann Arbor Living Wage Ordinance Declaration of Compliance**
- **City of Ann Arbor Prevailing Wage Declaration of Compliance**

**Bids that fail to provide these forms listed above upon bid opening may be rejected as non-responsive and may not be considered for award.**

Hand delivered bids may be dropped off in the Purchasing drop box located in the Ann Street (north) vestibule/entrance of City Hall which is open to the public at all hours. The City will not be liable to any Bidder for any unforeseen circumstances, delivery or postal delays. Postmarking to the Due Date will not substitute for receipt of the Bid. Each Bidder is responsible for submission of their Bid.

Additional time for submission of bids past the stated due date and time will not be granted to a single Bidder; however, additional time may be granted to all Bidders when the City determines in its sole discretion that circumstances warrant it

## Award

The City intends to award to the lowest responsive and responsible bidder.

A responsive and responsible bidder means a bid submitted, which conforms in all aspects of the requirements set forth in the invitation to bid. All aspects could include references, past experience, past performance, and qualifications.

Responsible bidder means a bid submitted, which conforms in all aspects of the requirements set forth in the invitation to bid. The City may, at its sole discretion, award line-by-line in the best interest of value to the City.

## Official Documents

The City of Ann Arbor officially distributes bid documents from the Procurement Unit or through the Michigan Intergovernmental Trade Network (MITN). Copies of the bid documents obtained from any other source are not Official copies. Addenda and other bid information will only be posted to these official distribution sites. If you obtained City of Ann Arbor Bid documents from other sources, it is recommended that you register on [www.MITN.info](http://www.MITN.info) and obtain an official Bid.

## Taxes

Municipalities are exempt from Michigan State Sales and Federal Excise taxes. Do not include such taxes in the bid figure(s). The City will furnish the successful bidder with tax exemption certificates when requested.

## Withdrawal of Bids

After the time of opening, no Bid may be withdrawn for the period of one-hundred and twenty (120) days.

## Non-Discrimination Requirements

All contractors proposing to do business with the City shall satisfy the non-discrimination administrative policy adopted by the City Administrator in accordance with the Section 9:158 of the Ann Arbor City Code. Breach of the obligation not to discriminate shall be a material breach of the contract. Contractors are required to post a copy of Ann Arbor's Non-Discrimination Ordinance attached at all work locations where its employees provide services under a contract with the City.

## Wage Requirements

The successful bidder and its subcontractors must comply with all applicable requirements and provide proof of compliance.

Pursuant to Resolution R-16-469 all public improvement contractors are subject to prevailing wage and will be required to provide to the City payroll records sufficient to demonstrate compliance with the prevailing wage requirements. Use of the Certified Payroll Form provided in the Attachment section or a City-approved equivalent will be required.

For laborers whose wage level are subject to federal, state and/or local prevailing wage law the appropriate Davis-Bacon wage rate classification is identified based upon the work including within this contract. **The wage determination(s) current on the date 10 days before bids are due shall apply to this contract.** The U.S. Department of Labor (DOL) has provided explanations to assist with classification in the following resource link: [beta.SAM.gov](http://beta.SAM.gov).

For the purposes of this ITB the Construction Type of Building will apply

## Living Wage Requirements

If the Contractor is a "covered employer" as defined in Chapter 23 of the Ann Arbor City Code, the Contractor agrees to comply with the living wage provisions of Chapter 23 of the Ann Arbor City Code. The Contractor agrees to pay those employees providing Services to the City under this Agreement a "living wage," as defined in Section 1:815 of the Ann Arbor City Code, as adjusted in accordance with Section 1:815(3); to post a notice approved by the City of the applicability of Chapter 23 in every location in which regular or contract employees providing services under this Agreement are working; to maintain records of compliance; if requested by the City, to provide documentation to verify compliance; to take no action that would reduce the compensation, wages, fringe benefits, or leave available to any employee or person contracted for employment in order to pay the living wage required by Section 1:815; and otherwise to comply with the requirements of Chapter 23.

## Conflict Of Interest Disclosure

The City of Ann Arbor Purchasing Policy requires that prospective Vendors complete a Conflict of Interest Disclosure form. A contract may not be awarded to the selected Vendor unless and until the Procurement Unit and the City Administrator have reviewed the Disclosure form and determined that no conflict exists under applicable federal, state, or local law or administrative regulation. Not every relationship or situation disclosed on the Disclosure Form may be a disqualifying conflict. Depending on applicable law and regulations, some contracts may awarded on the recommendation of the City Administrator after full disclosure, where such action is allowed by law, if demonstrated competitive pricing exists and/or it is determined the award is in the best interest of the City. A copy of the Vendor Conflict of Interest Disclosure Form is attached.

## Debarment

Submission of a Bid in response to this ITB is certification that the Bidder is not currently debarred, suspended, proposed for debarment, and declared ineligible or voluntarily excluded from participation in this transaction by any State or Federal departments or agency. Submission is also agreement that the City will be notified of any changes in this status.

## Disclosures

After bids are opened, all information in a submitter's bid is subjected to disclosure under the provisions of Michigan Public Act No. 442 of 1976, as amended (MCL 15.231 et seq.) known as the "Freedom of Information Act." The Freedom of Information Act also provides for the complete disclosure of contracts and attachments thereto except where specifically exempted.

## Bid Protest

All Bid protests must be in writing and filed with the Purchasing Agent within five (5) business days of the award action. The bidder must clearly state the reasons for the protest. If a bidder contacts a City Service Area/Unit and indicates a desire to protest an award, the Service Area/Unit shall refer the bidder to the Purchasing Agent. The Purchasing Agent will provide the bidder with the appropriate instructions for filing the protest. The protest shall be reviewed by the City Administrator or designee whose decision shall be final.

Any inquiries or requests regarding this procurement should be only submitted in writing to the Designated City Contacts provided herein. Attempts by a bidder to initiate contact with anyone other than the Designated City Contacts provided herein that the prospective bidder believes can influence the procurement decision, e.g., Elected Officials, City Administrator, Selection Committee Members, Appointed Committee Members, etc., may lead to immediate elimination from further consideration.

## Cost Liability

The City of Ann Arbor assumes no responsibility or liability for costs incurred by the Bidder prior

to the execution of a contract with the City. By submitting a bid, a bidder agrees to bear all costs incurred or related to the preparation, submission and selection process for the bid.

### **Reservation of Rights**

The City of Ann Arbor reserves the right to accept any bid or alternative bid proposed in whole or in part, to reject any or all bids or alternatives bids in whole or in part and to waive irregularity and/or informalities in any bid and to make the award in any manner deemed in the best interest of the City.

### **Environmental Commitment**

The City of Ann Arbor recognizes its responsibility to minimize negative impacts on human health and the environment while supporting a vibrant community and economy. The City further recognizes that the products and services the City buys have inherent environmental and economic impacts and that the City should make procurement decisions that embody, promote, and encourage the City's commitment to the environment.

The City encourages potential vendors to bring forward emerging and progressive products and services that are best suited to the City's environmental principles

**INVITATION TO BID**

City of Ann Arbor  
Guy C. Larcom Municipal Building  
Ann Arbor, Michigan 48107

Ladies and Gentlemen:

The undersigned, as Bidder, declares that this Bid is made in good faith, without fraud or collusion with any person or persons bidding on the same Contract; that this Bidder has carefully read and examined the bid documents, including City Nondiscrimination requirements, Vendor Conflict of Interest Form, Living Wage requirements, Instructions to Bidders, Bid Forms, Purchase Order Terms and Conditions, General Conditions, Detailed Specifications, and all Addenda, and understands them. The Bidder declares that it conducted a full investigation of the work proposed and is fully informed as to the nature of the work and the conditions relating to the work's performance.

The Bidder acknowledges that it has not received or relied upon any representations or warrants of any nature whatsoever from the City of Ann Arbor, its agents or employees, and that this Bid is based solely upon the Bidder's own independent business judgment.

*In accordance with these bid documents, and Addenda numbered \_\_\_\_\_, the undersigned, as Bidder, proposes to deliver to the City all product/services herein described for the amounts set forth in the Bid Forms.*

The Bidder declares that it has become fully familiar with the liquidated damage clauses for completion times and for compliance with City Code Chapter 112, understands and agrees that the liquidated damages are for the non-quantifiable aspects of non-compliance and do not cover actual damages that may be shown and agrees that if awarded the Contract, all liquidated damage clauses form part of the Contract.

Bidder further agrees that the cited provisions of Chapter 14 and Chapter 23 form a part of this Contract.

The Bidder declares that it has become familiar with the City Conflict of Interest Disclosure Form and certifies that the statement contained therein is true and correct.

In submitting this Bid, it is understood that the right is reserved by the City to accept any Bid, to reject any or all Bids, to waive irregularities and/or informalities in any Bid, and to make the award in any manner the City believes to be in its best interest.

SIGNED THIS 6th DAY OF May, 2021.

Applied Handling  
Bidder's Name

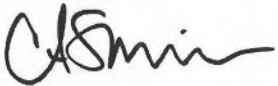
  
Authorized Signature of Bidder

15200 Century Dr  
Dearborn, MI 48120  
Official Address

Craig Sturgis  
(Print Name of Signer Above)

313-336-8020  
Telephone Number

mwozniak@appliedhandling.com  
Email Address for Award Notice

**LEGAL STATUS OF BIDDER**

(The Bidder shall fill out the appropriate form and strike out the other three.)

Bidder declares that it is:

\* A corporation organized and doing business under the laws of the State of Wisconsin \_\_\_\_\_, for whom Craig Sturgis \_\_\_\_\_, bearing the office title of Executive V.P. \_\_\_\_\_, whose signature is affixed to this Bid, is authorized to execute contracts.

**NOTE: If not incorporated in Michigan, please attach the corporation's Certificate of Authority**

• ~~A limited liability company doing business under the laws of the State of \_\_\_\_\_, whom \_\_\_\_\_ bearing the title of \_\_\_\_\_ whose signature is affixed to this proposal, is authorized to execute contract on behalf of the LLC.~~

\* A partnership, organized under the laws of the state of \_\_\_\_\_ and filed in the county of \_\_\_\_\_, whose members are (list all members and the street and mailing address of each) (attach separate sheet if necessary):

\_\_\_\_\_  
\_\_\_\_\_  
\_\_\_\_\_  
\_\_\_\_\_

\* An individual, whose signature with address, is affixed to this Bid: \_\_\_\_\_ (initial here)

**Authorized Official**

\_\_\_\_\_ **Date** \_\_\_\_\_, 2021

(Print) Name Craig Sturgis \_\_\_\_\_ Title Executive V.P. \_\_\_\_\_

Company: Applied Handling \_\_\_\_\_

Address: 15200 Century Dr Dearborn, MI 48120 \_\_\_\_\_

Contact Phone (313) 336-8020 \_\_\_\_\_ Fax ( ) \_\_\_\_\_

Email csturgis@appliedhandling.com \_\_\_\_\_



## SPECIFICATIONS

In order to be considered for award the bid must be 100% compliant with the minimum specifications below. Any bids that state exceptions or alternates that do not meet the minimum specifications provided herein will be rejected as non-responsive and will not be considered for award.

### Scope of Work

- A. The vendor shall provide all supervision, equipment, and labor to supply; deliver and install seven (7) garage doors with red colored panels and three rows of insulated glass windows, seven (7) new openers (carriers), all of the necessary track, seven (7) door safety systems, all of the necessary weather stripping, and all of the associated (necessary) hardware at City of Ann Arbor Fire Station 1, 111 North Fifth Avenue, Ann Arbor, MI 48104.
- B. Vendor shall coordinate all work sequences with City Facilities and Fire Department staff to minimize disruption of Fire Department activities.
- C. Vendor shall make every effort to remove existing and install new door on same day. If new door cannot be installed on same day, Vendor shall provide temporary opening protection.
- D. Vendor shall be responsible for removal and disposal of all demolished materials, trash, and other construction debris off site.
- E. At no time shall more than two apparatus bay garage doors shall be unavailable at any one time.
- F. The total installation process shall not exceed seven continuous calendar days.

Does Your Bid Comply With All Aspects of This Section? Yes  No

### Garage Doors

- No existing doors, track, sensors, or any other hardware be may reused.
- The vendor shall measure the door size to ensure properly sized door for each of the of seven (7) openings. Our measurements are showing six (6) 12' 3¼" wide x 12' 7" tall and one (1) 16'-2" wide x 12'-9" tall
- All doors shall have at minimum: 100,000 cycle springs and 3" tracks mounting to steel jambs.
- The bottom row of each door shall be panels.
- The second, third and fourth rows from the bottom shall be insulated glass. The windows of the second, third and fourth row shall be full view glass that is minimum ½" insulated tempered glass.
- All remaining rows above the three rows of glass shall panels.
- Non-glass panels shall be at minimum 16.0 R-value.
- Full weather brush type seals on the bottom, top, and sides of all new doors.
- The exterior color of all the panels and door frame shall be red. Preference shall be given to factory paint versus paint applied after installation.
- All bids should include color specification and samples.
- Shop drawings of the doors should be provided with each bid.

Does Your Bid Comply With All Aspects Of This Section? Yes  No

### Door Openers

- No existing motors shall be re-used.
- All seven (7) door openers shall be at minimum commercial grade, high-speed gearhead style hoist motors.
- All openers shall have emergency release, brake, safety photocells, two (2) single hand-held transmitters for each opener, and a 3-button wall station for each door.

- Each door shall have two sets of safety photocells: one at the standard 6" floor height and another at 5'. Only bottom safety photocell needs to be monitored.
- Door opener voltage: 120 VAC 1 PH
- Door opener horse power: ½ HP (minimum)
- The base price quote shall include a 3-button wall station for each door mounted in the current location of the 3-button wall station for each door. The location of the wall station for door 7 shall be relocated to the south side of the door.
- Add separate cost line item for all openers to connect to a new main control panel mounted on the outside of the office area next to bay 2.
- Doors shall not have a reversing edge.

Does Your Bid Comply With All Aspects Of This Section? Yes  X  No \_\_\_\_\_

### Maintenance and Warranty Program

- The vendor shall guarantee and warrant the overhead garage doors and door tracks for a period of at least one (1) year against all manufacturer's and/or installation defects including the glazing.
- The vendor shall guarantee and warrant the overhead garage door opener, including the remotes, for a period of at least two (2) years against all manufacturer's and/or installation defects.
- The vendor shall provide two years of onsite annual preventative maintenance to all installed garage doors, tracks, openers, and installed components at no additional cost.
- This guarantee/warranty period shall commence following the possession of the specific unit by the City of Ann Arbor.

Does Your Bid Comply With All Aspects Of This Section? Yes  X  No \_\_\_\_\_

**BID FORM - PRICING**

**VENDOR NAME:** Applied Handling

The bidder further agrees and understands that the City of Ann Arbor reserves the right to accept any Bid, to reject any or all Bids, to waive irregularities and/or informalities in any Bid, to make the award in any manner the City believes to be in its best interest, and to reduce or eliminate this purchase agreement without prior notice. Unit Prices must be firm for the entire term of the Contract.

**For the entire work outlined in these documents for the bidder to provide all equipment, hardware and installation for a fully functioning and complete New Garage Doors for Fire Station 1 as described herein:**

Sixty Seven Thousand Four Hundred Sixty Three Dollars 31/100 (\$ 67,463.31 )

**Delivery time after receipt of PO:** Lead Time is 6-8 weeks after approval drawings

**ALTERNATES**

**Alternate items may be selected for award at the discretion of the City.  
All Alternates listed below should be bid.**

ALTERNATE #1 – may be ADDED to the Base Bid.  
All openers to connect to a new main control panel mounted on the outside of the office area next to bay 2.

ADD COST \$ \_\_\_\_\_ (\$ \_\_\_\_\_ )

## BID FORM – REFERENCES

Please list at least three references with whom you have had similar contracts during the past three years.

1.    Company or City   Brivar Construction/ Brighton Fire Station  
      Contact Name       Jon Schwartz  
      Telephone Number   248-446-8000  
      E-mail               jon@brivar.com
  
2.    Company or City   \_\_\_\_\_
- Contact Name       \_\_\_\_\_
- Telephone Number   \_\_\_\_\_
- E-mail               \_\_\_\_\_
  
3.    Company or City   \_\_\_\_\_
- Contact Name       \_\_\_\_\_
- Telephone Number   \_\_\_\_\_
- E-mail               \_\_\_\_\_

# BID FORM

## CONTRACTOR INFORMATION AND RESPONSIBLE CONTRACTOR CRITERIA

*Backup documentation may be requested at the sole discretion of the City to validate all of the responses provided herein by bidders. False statements by bidders to any of the criteria provided herein will result in the bid being considered non-responsive and will not be considered for award.*

*Failure to provide responses to all questions may result in being deemed non-responsive.*

*Attach additional pages as needed if space below is insufficient.*

Pursuant to Sec 1:312(20) of the City Code which sets forth requirements of a responsible bidder, Bidder is required to submit the following:

1. Organization Name: Applied Handling

Social Security or Federal Employer I.D. #: 37-1937656

Address: 15200 Century Dr

City: Dearborn State: MI Zip: 48120

Type of Organization (circle one below):

Individual          Partnership          Corporation          Joint Venture          Other

If "Other" please provide details on the organization:

\_\_\_\_\_

Year organization established: 1952

2. Current owners/principals/members/managing members/partners of the organization:

Scott Murray / Craig Sturgis

3. Assumed Names, "doing business as" d/b/a, and/or former organization names(s), if applicable: \_\_\_\_\_

Explanation of any business name changes:

\_\_\_\_\_

4. If applicable, please provide a list of all bidder's litigation and arbitrations currently pending and within the past five years, including an explanation of each (parties, court/forum, legal claims, damages sought, and resolution).

N/A

---

5. Qualifications of management and supervisory personnel to be assigned by the bidder:

---

6. List the state and local licenses and license numbers held by the bidder:

---

7. Will all subcontractors, employees and other individuals working on the construction project maintain current applicable licenses required by law for all licensed occupations and professions?

Yes

No

8. Will contractors, subcontractors, employees, and other individuals working on the construction project be misclassified by bidder as independent contractors in violation of state or federal law?

Yes

No

9. Submit a statement as to what percentage of your work force resides within the City of Ann Arbor, and what percentage resides in Washtenaw County, Michigan, and the same information for any major subcontractors.

---

10. Submit documentation as to bidder's employee pay rates (e.g., certified payroll without SSN or personal identifying information, or chart of job titles and pay rates, or other evidence).

11. State whether bidder provides health insurance, pension or other retirement benefits, paid leave (vacation, personal time, sick leave, etc), or other benefits to its employees, and if so, state whether each benefit is provided directly to employees, by payments or contributions to a third-party administered plan, in cash (e.g., fringe benefit portion of prevailing wages), or other manner.

*Yes*

---

12. State whether bidder is an equal opportunity employer and does not discriminate in its hiring on the basis of race, sex, pregnancy, age, religion, national origin, marital status, sexual orientation or gender identity, height, weight, or disability.

Yes

No

13. State whether bidder has Equal Employment Opportunity Programs for minorities, women, veterans, returning citizens, and small businesses, and if so, submit supporting documentation or other evidence of such program(s).

Yes

---

14. Has bidder had any violations of state, federal, or local laws or regulations, including OSHA or MIOSHA violations, state or federal prevailing wage laws, wage and hour laws, worker's compensation or unemployment compensation laws, rules or regulations, issued to or against the bidder within the past five years?

Yes

No

If you answered "yes" to the question above, for each violation provide an explanation of the nature of the violation, the agency involved, a violation or reference number, any other individual(s) or party(ies) involved, and the status or outcome and resolution.

15. Does bidder have an existing Fitness for Duty Program (drugs and alcohol testing) of each employee working on the proposed jobsite?

Yes

No

If you answered "Yes", please submit documentation of the Fitness for Duty Program and what it entails.

16. Submit documents or evidence of any debarment by any federal, state or local governmental unit and/or findings of non-responsibility or non-compliance with respect to any public or private construction project performed by the bidder.

17. Proof of insurance, including certificates of insurance, confirming existence and amount of coverage for liability, property damage, workers compensation, and any other insurances required by the proposed contract documents

## **GENERAL CONDITIONS**

### **DOWN PAYMENTS**

Any bid proposal submitted which requires a down payment or prepayment of any kind prior to delivery and acceptance of the item, as being in conformance with the specifications will not be considered for award.

### **CONTRACT TERM**

The pricing provided for this ITB shall be firm for one (1) year or until project completion



# APPENDIX A: SAMPLE PURCHASE AGREEMENT

*If a contract is awarded, the selected Firm(s) will be required to adhere to a set of general contract provisions which will become a part of any formal agreement. These provisions are general principles which apply to all contractors/service providers to the City of Ann Arbor. The required provisions are:*

## GENERAL SERVICES AGREEMENT BETWEEN

\_\_\_\_\_

AND THE CITY OF ANN ARBOR

FOR \_\_\_\_\_

ITB NO. \_\_\_\_\_

This agreement ("Agreement") is between the City of Ann Arbor, a Michigan municipal corporation, having its offices at 301 E. Huron St. Ann Arbor, Michigan 48104 ("City"), and \_\_\_\_\_ Applied Handling \_\_\_\_\_ Contractor"), a State of Michigan limited liability company, with its address at \_\_\_\_\_. City and Contractor are referred to collectively herein as the "Parties." The Parties agree as follows:

### I. DEFINITIONS

Administering Service Area/Unit means \_\_\_\_\_

Contract Administrator means \_\_\_\_\_, acting personally or through any assistants authorized by the Administrator/Manager of the Administering Service Area/Unit.

Deliverables means all Plans, Specifications, Reports, Recommendations, and other materials developed for and delivered to City by Contractor under this Agreement.

Project means \_\_\_\_\_ ITB No. \_\_\_\_\_ and all Addendum.

### II. DURATION

Contractor shall commence performance on \_\_\_\_\_, 2020 ("Commencement Date"). This Agreement shall remain in effect until satisfactory completion of the Services specified below unless terminated as provided for in Article XII. The terms and conditions of this Agreement shall apply to the earlier of the Effective Date or Commencement Date.

### III. SERVICES

- A. The Contractor agrees to provide scope of services as described in City of Ann Arbor ITB \_\_\_\_\_ as amended ("Services") and to furnish all materials, equipment and labor necessary and to abide by all the duties and responsibilities applicable to it for the Project in accordance with the requirements and provisions of the following documents ("Contract Documents"), including all written modifications incorporated into any of the documents, which are incorporated as part of this Agreement:

This Agreement and Exhibits

Invitation to Bid No. 4681 and all Addendum thereto (if any)

Bid Proposal of Contractor, dated May 6, 2021, and restated and attached as Exhibit A.

The Contract Documents are complementary and what is called for by any one shall be binding. The intention of the documents is to include all labor and materials, equipment, and transportation necessary for the proper execution of the Project. Materials or work described in words that so applied have a well-known technical or trade meaning have the meaning of those recognized standards.

In case of a conflict among the Contract Documents, the requirement(s) of the document listed first above shall prevail over any conflicting requirement(s) of a document listed later.

The City retains the right to make changes to the quantities of service within the general scope of the Agreement at any time by a written order. If the changes add to or deduct from the extent of the services, the compensation shall be adjusted accordingly. All such changes shall be executed under the conditions of the original Agreement.

- B. Quality of Services under this Agreement shall be of the level of quality performed by persons regularly rendering this type of service. Determination of acceptable quality shall be made solely by the Contract Administrator.
- C. The Contractor shall perform its Services for the Project in compliance with all statutory, regulatory and contractual requirements now or hereafter in effect as may be applicable to the rights and obligations set forth in the Agreement. The Contractor shall also comply with and be subject to the City of Ann Arbor policies applicable to independent contractors
- D. The Contractor may rely upon the accuracy of reports and surveys provided to it by the City (if any) except when defects should have been apparent to a reasonably competent professional or when it has actual notice of any defects in the reports and surveys.

#### **IV. INDEPENDENT CONTRACTOR**

The Parties agree that at all times and for all purposes under the terms of this Agreement each Party's relationship to any other Party shall be that of an independent contractor. Each Party will be solely responsible for the acts of its own employees, agents, and servants. No liability, right, or benefit arising out of any employer/employee relationship, either express or implied, shall arise or accrue to any Party as a result of this Agreement.

Contractor does not have any authority to execute any contract or agreement on behalf of the City, and is not granted any authority to assume or create any obligation or liability on the City's behalf, or to bind the City in any way.

## V. COMPENSATION OF CONTRACTOR

- A. The Contractor shall be paid on the basis of the bid price restated in Exhibit B The total fee to be paid the Contractor for the Services shall not exceed \_\_\_\_\_ (\$\_\_\_\_\_). Payment shall be made monthly, unless another payment term is specified in Exhibit B, following receipt of invoices submitted by the Contractor, and approved by the Contract Administrator.
- B. The Contractor will be compensated for Services performed in addition to the Services described in Article III, only when the scope of and compensation for those additional Services have received prior written approval of the Contract Administrator.
- C. The Contractor shall keep complete records of work performed (e.g. tasks performed/hours allocated) so that the City may verify invoices submitted by the Contractor. Such records shall be made available to the City upon request and submitted in summary form with each invoice.

## VI. INSURANCE/INDEMNIFICATION

- A. The Contractor shall procure and maintain from the Effective Date or Commencement Date of this Agreement (whichever is earlier) through the conclusion of this Agreement, such insurance policies, including those set forth in Exhibit C, as will protect itself and the City from all claims for bodily injuries, death, or property damage which may arise under this Agreement; whether the act(s) or omission(s) giving rise to the claim were made by the Contractor, any subcontractor, or anyone employed by them directly or indirectly. Prior to commencement of work under this Agreement, Contractor shall provide to the City documentation satisfactory to the City, through City-approved means (currently myCOI), demonstrating it has obtained the policies and endorsements required by Exhibit C. Contractor shall add registration@mycoitracking.com to its safe sender's list so that it will receive necessary communication from myCOI. When requested, Contractor shall provide the same documentation for its subcontractor(s) (if any).
- B. Any insurance provider of Contractor shall be authorized to do business in the State of Michigan and shall carry and maintain a minimum rating assigned by A.M. Best & Company's Key Rating Guide of "A-" Overall and a minimum Financial Size Category of "V". Insurance policies and certificates issued by non-admitted insurance companies are not acceptable unless approved in writing by the City.
- C. To the fullest extent permitted by law, Contractor shall indemnify, defend and hold the City, its officers, employees and agents harmless from all suits, claims, judgments and expenses, including attorney's fees, resulting or alleged to result, from any acts or omissions by Contractor or its employees and agents occurring in the performance of or breach in this Agreement, except to the extent that any suit, claim, judgment or expense are finally judicially determined to have resulted from the City's negligence or willful misconduct or its failure to comply with any of its material obligations set forth in this Agreement

## **VII. WAGE REQUIREMENTS**

Under this Agreement, the Contractor shall conform to Chapter 14 of Title I of the Code of the City of Ann Arbor as amended; which in part states "...that all craftsmen, mechanics and laborers employed directly on the site in connection with said improvements, including said employees of subcontractors, shall receive the prevailing wage for the corresponding classes of craftsmen, mechanics and laborers, as determined by statistics for the Ann Arbor area compiled by the United States Department of Labor. At the request of the City, any contractor or subcontractor shall provide satisfactory proof of compliance with the contract provisions required by the Section."

Where the Agreement and the Ann Arbor City Code of Ordinance are silent as to definitions of terms required in determining compliance with regard to prevailing wages, the definitions provided in the Davis-Bacon Act as amended (40 U.S.C. 278-a to 276-a-7) for the terms shall be used.

If the Contractor is a "covered employer" as defined in Chapter 23 of the Ann Arbor City Code, the Contractor agrees to comply with the living wage provisions of Chapter 23 of the Ann Arbor City Code. The Contractor agrees to pay those employees providing Services to the City under this Agreement a "living wage," as defined in Section 1:815 of the Ann Arbor City Code, as adjusted in accordance with Section 1:815(3); to post a notice approved by the City of the applicability of Chapter 23 in every location in which regular or contract employees providing services under this Agreement are working; to maintain records of compliance; if requested by the City, to provide documentation to verify compliance; to take no action that would reduce the compensation, wages, fringe benefits, or leave available to any employee or person contracted for employment in order to pay the living wage required by Section 1:815; and otherwise to comply with the requirements of Chapter 23.

Contractor agrees that all subcontracts entered into by the Contractor shall contain similar wage provision covering subcontractor's employees who perform work on this Agreement.

## **VIII. NON-DISCRIMINATION**

The Contractor agrees to comply, and to require its subcontractor(s) to comply, with the nondiscrimination provisions of MCL 37.2209. The Contractor further agrees to comply with the provisions of Section 9:158 of Chapter 112 of Title IX of the Ann Arbor City Code, and to assure that applicants are employed and that employees are treated during employment in a manner which provides equal employment opportunity.

## **IX. REPRESENTATIONS AND WARRANTIES BY THE CONTRACTOR**

- A. The Contractor warrants that the quality of its Services under this Agreement shall conform to the level of quality performed by persons regularly rendering this type of service.
- B. The Contractor warrants that it has all the skills, experience and licenses (if applicable) necessary to perform the Services it is to provide pursuant to this Agreement.
- C. The Contractor warrants that it has available, or will engage, at its own expense, sufficient trained employees to provide the Services it is to provide pursuant to this Agreement.
- D. The Contractor certifies that it has no personal or financial interest in the Project other than the fee it is to receive under this Agreement. The Contractor further certifies that it shall not acquire any such interest, direct or indirect, which would

conflict in any manner with the performance of the Services it is to provide pursuant to this Agreement. Further Contractor agrees and certifies that it does not and will not employ or engage any person with a personal or financial interest in this Agreement.

- E. The Contractor certifies that it is not, and shall not become overdue or in default to the City for any contract, debt, or any other obligation to the City including real and personal property taxes. Further Contractor agrees that the City shall have the right to set off any such debt against compensation awarded for Services under this Agreement.
- F. The Contractor warrants that its bid was made in good faith, it arrived at the costs of its bid independently, without consultation, communication or agreement, for the purpose of restricting completion as to any matter relating to such fees with any competitor for these Services; and no attempt has been made or shall be made by the Contractor to induce any other person or firm to submit or not to submit a bid for the purpose of restricting competition.
- G. The person signing this Agreement on behalf of Contractor represents and warrants that she/he has express authority to sign this Agreement for Contractor and agrees to hold the City harmless for any costs or consequences of the absence of actual authority to sign.

#### **X. OBLIGATIONS OF THE CITY**

- A. The City agrees to give the Contractor access to the Project area and other City-owned properties as required to perform the necessary Services under this Agreement.
- B. The City shall notify the Contractor of any defects in the Services of which the Contract Administrator has actual notice.

#### **XI. ASSIGNMENT**

- A. The Contractor shall not subcontract or assign any portion of any right or obligation under this Agreement without prior written consent from the City. Notwithstanding any consent by the City to any assignment, Contractor shall at all times remain bound to all warranties, certifications, indemnifications, promises and performances, however described, as are required of it under the Agreement unless specifically released from the requirement, in writing, by the City.
- B. The Contractor shall retain the right to pledge payment(s) due and payable under this Agreement to third parties.

#### **XII. TERMINATION OF AGREEMENT**

- A. If either party is in breach of this Agreement for a period of fifteen (15) days following receipt of notice from the non-breaching party with respect to a breach, the non-breaching party may pursue any remedies available to it against the breaching party under applicable law, including but not limited to, the right to terminate this Agreement without further notice. The waiver of any breach by any party to this Agreement shall not waive any subsequent breach by any party.
- B. The City may terminate this Agreement, on at least thirty (30) days advance notice,

for any reason, including convenience, without incurring any penalty, expense or liability to Contractor, except the obligation to pay for Services actually performed under the Agreement before the termination date.

- C. Contractor acknowledges that, if this Agreement extends for several fiscal years, continuation of this Agreement is subject to appropriation of funds for this Project. If funds to enable the City to effect continued payment under this Agreement are not appropriated or otherwise made available, the City shall have the right to terminate this Agreement without penalty at the end of the last period for which funds have been appropriated or otherwise made available by giving written notice of termination to Contractor. The Contract Administrator shall give Contractor written notice of such non-appropriation within thirty (30) days after it receives notice of such non-appropriation.
- D. The provisions of Articles VI and IX shall survive the expiration or earlier termination of this Agreement for any reason. The expiration or termination of this Agreement, for any reason, shall not release either party from any obligation or liability to the other party, including any payment obligation that has already accrued and Contractor's obligation to deliver all Deliverables due as of the date of termination of the Agreement.

### **XIII. REMEDIES**

- A. This Agreement does not, and is not intended to, impair, divest, delegate or contravene any constitutional, statutory and/or other legal right, privilege, power, obligation, duty or immunity of the Parties.
- B. All rights and remedies provided in this Agreement are cumulative and not exclusive, and the exercise by either party of any right or remedy does not preclude the exercise of any other rights or remedies that may now or subsequently be available at law, in equity, by statute, in any agreement between the parties or otherwise.
- C. Absent a written waiver, no act, failure, or delay by a Party to pursue or enforce any rights or remedies under this Agreement shall constitute a waiver of those rights with regard to any existing or subsequent breach of this Agreement. No waiver of any term, condition, or provision of this Agreement, whether by conduct or otherwise, in one or more instances, shall be deemed or construed as a continuing waiver of any term, condition, or provision of this Agreement. No waiver by either Party shall subsequently effect its right to require strict performance of this Agreement.

### **XIV. NOTICE**

All notices and submissions required under this Agreement shall be delivered to the respective party in the manner described herein to the address stated below or such other address as either party may designate by prior written notice to the other. Notices given under this Agreement shall be in writing and shall be personally delivered, sent by next day express delivery service, certified mail, or first class U.S. mail postage prepaid, and addressed to the person listed below. Notice will be deemed given on the date when one of the following first occur: (1) the date of actual receipt; (2) the next business day when notice is sent next day express delivery service or personal delivery; or (3) three days after mailing first class or certified U.S. mai

If Notice is sent to the CONTRACTOR, it shall be addressed and sent to:

If Notice is sent to the CITY, it shall be addressed and sent to:

City of Ann Arbor  
ATTN: Fire Chief  
301 E. Huron St.  
Ann Arbor, Michigan 48104

With a copy to: The City of Ann Arbor  
ATTN: Office of the City Attorney  
301 East Huron Street, 3<sup>rd</sup> Floor  
Ann Arbor, Michigan 48104

#### **XV. CHOICE OF LAW AND FORUM**

This Agreement will be governed and controlled in all respects by the laws of the State of Michigan, including interpretation, enforceability, validity and construction, excepting the principles of conflicts of law. The parties submit to the jurisdiction and venue of the Circuit Court for Washtenaw County, State of Michigan, or, if original jurisdiction can be established, the United States District Court for the Eastern District of Michigan, Southern Division, with respect to any action arising, directly or indirectly, out of this Agreement or the performance or breach of this Agreement. The parties stipulate that the venues referenced in this Agreement are convenient and waive any claim of non-convenience.

#### **XVI. OWNERSHIP OF DOCUMENTS**

Upon completion or termination of this Agreement, all documents (i.e., Deliverables) prepared by or obtained by the Contractor as provided under the terms of this Agreement shall be delivered to and become the property of the City. Original basic survey notes, sketches, charts, drawings, partially completed drawings, computations, quantities and other data shall remain in the possession of the Contractor as instruments of service unless specifically incorporated in a deliverable, but shall be made available, upon request, to the City without restriction or limitation on their use.

#### **XVII. SEVERABILITY OF PROVISIONS**

Whenever possible, each provision of this Agreement will be interpreted in a manner as to be effective and valid under applicable law. However, if any provision of this Agreement or the application of any provision to any party or circumstance will be prohibited by or invalid under applicable law, that provision will be ineffective to the extent of the prohibition or invalidity without invalidating the remainder of the provisions of this Agreement or the application of the provision to other parties and circumstances

## **XVIII. EXTENT OF AGREEMENT**

This Agreement, together Exhibits A, B, and C, and the other Contract Documents, constitutes the entire understanding between the City and the Contractor with respect to the subject matter of the Agreement and it supersedes, unless otherwise incorporated by reference herein, all prior representations, negotiations, agreements or understandings whether written or oral. Neither party has relied on any prior representations, of any kind or nature, in entering into this Agreement. No terms or conditions of either party's invoice, purchase order or other administrative document shall modify the terms and conditions of this Agreement, regardless of the other party's failure to object to such form. This Agreement shall be binding on and shall inure to the benefit of the parties to this Agreement and their permitted successors and permitted assigns and nothing in this Agreement, express or implied, is intended to or shall confer on any other person or entity any legal or equitable right, benefit, or remedy of any nature whatsoever under or by reason of this Agreement. This Agreement may only be altered, amended or modified by written amendment signed by the Contractor and the City. This Agreement may be executed in counterparts, each of which shall be deemed an original, but all of which together shall be deemed to be one and the same agreement.

## **XIX. ELECTRONIC TRANSACTION**

The parties agree that signatures on this Agreement may be delivered electronically in lieu of an original signature and agree to treat electronic signatures as original signatures that bind them to this Agreement. This Agreement may be executed and delivered by facsimile and upon such delivery, the facsimile signature will be deemed to have the same effect as if the original signature had been delivered to the other party.

## **XX. EFFECTIVE DATE**

This Agreement will become effective when all parties have signed it. The Effective Date of this Agreement will be the date this Agreement is signed by the last party to sign it.

**[REMAINDER OF PAGE LEFT BLANK; SIGNATURE PAGE FOLLOWS]**



**FOR CONTRACTOR**

By Applied Handling  
Type Name

Its \_\_\_\_\_

This 6 day of May, 2021

**FOR THE CITY OF ANN ARBOR**

By \_\_\_\_\_  
Christopher Taylor, Mayor

By \_\_\_\_\_  
Jacqueline Beaudry, City Clerk

This \_\_\_ day of \_\_\_\_\_, 20\_\_\_

**Approved as to substance**

By \_\_\_\_\_  
Tom Crawford, City Administrator

\_\_\_\_\_  
Mike Kennedy, Fire Chief

**Approved as to form and content**

\_\_\_\_\_  
Stephen K. Postema, City Attorney

**EXHIBIT A  
SCOPE OF SERVICES**

**EXHIBIT B  
COMPENSATION**

General

Contractor shall be paid for those Services performed pursuant to this Agreement inclusive of all reimbursable expenses (if applicable), in accordance with the terms and conditions herein. The Compensation Schedule below/attached states nature and amount of compensation the Contractor may charge the City:

Shall not exceed \_\_\_\_\_ (\$ \_\_\_\_\_)

**EXHIBIT C  
INSURANCE REQUIREMENTS**

From the earlier of the Effective Date or the Commencement Date of this Agreement, and continuing without interruption during the term of this Agreement, Contractor shall provide certificates of insurance to the City on behalf of itself, and when requested any subcontractor(s).

(1) The certificates of insurance and required endorsements shall meet the following minimum requirements:

(a) Worker's Compensation Insurance in accordance with all applicable state and federal statutes. Further, Employers Liability Coverage shall be obtained in the following minimum amounts:

Bodily Injury by Accident - \$500,000 each accident  
Bodily Injury by Disease - \$500,000 each employee  
Bodily Injury by Disease - \$500,000 each policy limit

(b) Commercial General Liability Insurance equivalent to, as a minimum, Insurance Services Office form CG 00 01 04 13 or current equivalent. The City of Ann Arbor shall be named as an additional insured. There shall be no added exclusions or limiting endorsements specifically for the following coverages: Products and Completed Operations, Explosion, Collapse and Underground coverage or Pollution. Further there shall be no added exclusions or limiting endorsements that diminish the City's protections as an additional insured under the policy. The following minimum limits of liability are required:

\$1,000,000	Each occurrence as respect Bodily Injury Liability or Property Damage Liability, or both combined.
\$2,000,000	Per Project General Aggregate
\$1,000,000	Personal and Advertising Injury
\$2,000,000	Products and Completed Operations Aggregate

(c) Motor Vehicle Liability Insurance, including Michigan No-Fault Coverages, equivalent to, as a minimum, Insurance Services Office form CA 00 01 10 13 or current equivalent. Coverage shall include all owned vehicles, all non-owned vehicles and all hired vehicles. The City of Ann Arbor shall be named as an additional insured. There shall be no added exclusions or limiting endorsements that diminish the City's protections as an additional insured under the policy. Further, the limits of liability shall be \$1,000,000 for each occurrence as respects Bodily Injury Liability or Property Damage Liability, or both combined.

(d) Umbrella/Excess Liability Insurance shall be provided to apply excess of the Commercial General Liability, Employers Liability and the Motor Vehicle coverage enumerated above, for each occurrence and for aggregate in the amount of \$1,000,000.

(2) Insurance required under subsection (1)(b) and (1)(c) above shall be considered primary as respects any other valid or collectible insurance that the City may possess, including any self-insured retentions the City may have; and any other insurance the City does possess shall be considered excess insurance only and shall not be required to contribute with this insurance. Further, the Contractor agrees to waive any right of recovery by its insurer against the City for any insurance listed herein

- (3) Insurance companies and policy forms are subject to approval of the City Attorney, which approval shall not be unreasonably withheld. Documentation must provide and demonstrate an unconditional and un-qualified 30-day written notice of cancellation in favor of the City of Ann Arbor. Further, the documentation must explicitly state the following: (a) the policy number(s); name of insurance company(s); name and address of the agent(s) or authorized representative(s); name(s), email address(es), and address of insured; project name; policy expiration date; and specific coverage amounts; (b) any deductibles or self-insured retentions which may be approved by the City, in its sole discretion; (c) that the policy conforms to the requirements specified Contractor shall furnish the City with satisfactory certificates of insurance and endorsements prior to commencement of any work. Upon request, the Contractor shall provide within 30 days a copy of the policy(ies) and all required endorsements to the City. If any of the above coverages expire by their terms during the term of this Contract, the Contractor shall deliver proof of renewal and/or new policies and endorsements to the Administering Service Area/Unit at least ten days prior to the expiration date.
- (4) Any Insurance provider of Contractor shall be authorized to do business in the State of Michigan and shall carry and maintain a minimum rating assigned by A.M. Best & Company's Key Rating Guide of "A-" Overall and a minimum Financial Size Category of "V". Insurance policies and certificates issued by non-authorized insurance companies are not acceptable unless approved in writing by the City.
- (5) City reserves the right to require additional coverage and/or coverage amounts as may be included from time to time in the Detailed Specifications for the Project.
- (6) The provisions of this Exhibit C shall survive the expiration or earlier termination of this contract for any reason



## Vendor Conflict of Interest Disclosure Form

All vendors interested in conducting business with the City of Ann Arbor must complete and return the Vendor Conflict of Interest Disclosure Form in order to be eligible to be awarded a contract. Please note that all vendors are subject to comply with the City of Ann Arbor's conflict of interest policies as stated within the certification section below.

If a vendor has a relationship with a City of Ann Arbor official or employee, an immediate family member of a City of Ann Arbor official or employee, the vendor shall disclose the information required below.

1. No City official or employee or City employee's immediate family member has an ownership interest in vendor's company or is deriving personal financial gain from this contract.
2. No retired or separated City official or employee who has been retired or separated from the City for less than one (1) year has an ownership interest in vendor's Company.
3. No City employee is contemporaneously employed or prospectively to be employed with the vendor.
4. Vendor hereby declares it has not and will not provide gifts or hospitality of any dollar value or any other gratuities to any City employee or elected official to obtain or maintain a contract.
5. Please note any exceptions below:

<b>Conflict of Interest Disclosure*</b>	
Name of City of Ann Arbor employees, elected officials or immediate family members with whom there may be a potential conflict of interest.	<input type="checkbox"/> Relationship to employee <input type="checkbox"/> Interest in vendor's company <input type="checkbox"/> Other (please describe in box below)

\*Disclosing a potential conflict of interest does not disqualify vendors. In the event vendors do not disclose potential conflicts of interest and they are detected by the City, vendor will be exempt from doing business with the City.

<b>I certify that this Conflict of Interest Disclosure has been examined by me and that its contents are true and correct to my knowledge and belief and I have the authority to so certify on behalf of the Vendor by my signature below:</b>		
<b>Vendor Name</b>	<b>Vendor Phone Number</b>	
<b>Signature of Vendor Authorized Representative</b>	<b>Date</b>	<b>Printed Name of Vendor Authorized Representative</b>

Questions about this form? Contact Procurement Office City of Ann Arbor Phone: 734/794-6500, [procurement@a2gov.org](mailto:procurement@a2gov.org)

**CITY OF ANN ARBOR  
DECLARATION OF COMPLIANCE**

Non-Discrimination Ordinance

The "non discrimination by city contractors" provision of the City of Ann Arbor Non-Discrimination Ordinance (Ann Arbor City Code Chapter 112, Section 9:158) requires all contractors proposing to do business with the City to treat employees in a manner which provides equal employment opportunity and does not discriminate against any of their employees, any City employee working with them, or any applicant for employment on the basis of actual or perceived age, arrest record, color, disability, educational association, familial status, family responsibilities, gender expression, gender identity, genetic information, height, HIV status, marital status, national origin, political beliefs, race, religion, sex, sexual orientation, source of income, veteran status, victim of domestic violence or stalking, or weight. It also requires that the contractors include a similar provision in all subcontracts that they execute for City work or programs.

In addition the City Non-Discrimination Ordinance requires that all contractors proposing to do business with the City of Ann Arbor must satisfy the contract compliance administrative policy adopted by the City Administrator. A copy of that policy may be obtained from the Purchasing Manager

The Contractor agrees:

- (a) To comply with the terms of the City of Ann Arbor's Non-Discrimination Ordinance and contract compliance administrative policy, including but not limited to an acceptable affirmative action program if applicable.
- (b) To post the City of Ann Arbor's Non-Discrimination Ordinance Notice in every work place or other location in which employees or other persons are contracted to provide services under a contract with the City.
- (c) To provide documentation within the specified time frame in connection with any workforce verification, compliance review or complaint investigation.
- (d) To permit access to employees and work sites to City representatives for the purposes of monitoring compliance, or investigating complaints of non-compliance.

The undersigned states that he/she has the requisite authority to act on behalf of his/her employer in these matters and has offered to provide the services in accordance with the terms of the Ann Arbor Non-Discrimination Ordinance. The undersigned certifies that he/she has read and is familiar with the terms of the Non-Discrimination Ordinance, obligates the Contractor to those terms and acknowledges that if his/her employer is found to be in violation of Ordinance it may be subject to civil penalties and termination of the awarded contract.

Applied Handling Inc  
Company Name

Marianne DePoole      5/7/2021  
Signature of Authorized Representative      Date

MARIANNE DEPOOLE, General Mgr  
Print Name and Title

15200 Century Dr., DBN, MI 48120  
Address, City, State, Zip

313-457-1114  
Phone/Email Address

**Questions about the Notice or the City Administrative Policy, Please contact:**  
Procurement Office of the City of Ann Arbor  
(734) 794-6500

## CITY OF ANN ARBOR NON-DISCRIMINATION ORDINANCE

Relevant provisions of Chapter 112, Nondiscrimination, of the Ann Arbor City Code are included below.  
You can review the entire ordinance at [www.a2gov.org/humanrights](http://www.a2gov.org/humanrights).

**Intent:** It is the intent of the city that no individual be denied equal protection of the laws; nor shall any individual be denied the enjoyment of his or her civil or political rights or be discriminated against because of actual or perceived age, arrest record, color, disability, educational association, familial status, family responsibilities, gender expression, gender identity, genetic information, height, HIV status, marital status, national origin, political beliefs, race, religion, sex, sexual orientation, source of income, veteran status, victim of domestic violence or stalking, or weight.

**Discriminatory Employment Practices:** No person shall discriminate in the hire, employment, compensation, work classifications, conditions or terms, promotion or demotion, or termination of employment of any individual. No person shall discriminate in limiting membership, conditions of membership or termination of membership in any labor union or apprenticeship program.

**Discriminatory Effects:** No person shall adopt, enforce or employ any policy or requirement which has the effect of creating unequal opportunities according to actual or perceived age, arrest record, color, disability, educational association, familial status, family responsibilities, gender expression, gender identity, genetic information, height, HIV status, marital status, national origin, political beliefs, race, religion, sex, sexual orientation, source of income, veteran status, victim of domestic violence or stalking, or weight for an individual to obtain housing, employment or public accommodation, except for a bona fide business necessity. Such a necessity does not arise due to a mere inconvenience or because of suspected objection to such a person by neighbors, customers or other persons.

**Nondiscrimination by City Contractors:** All contractors proposing to do business with the City of Ann Arbor shall satisfy the contract compliance administrative policy adopted by the City Administrator in accordance with the guidelines of this section. All city contractors shall ensure that applicants are employed and that employees are treated during employment in a manner which provides equal employment opportunity and tends to eliminate inequality based upon any classification protected by this chapter. All contractors shall agree not to discriminate against an employee or applicant for employment with respect to hire, tenure, terms, conditions, or privileges of employment, or a matter directly or indirectly related to employment, because of any applicable protected classification. All contractors shall be required to post a copy of Ann Arbor's Non-Discrimination Ordinance at all work locations where its employees provide services under a contract with the city.

**Complaint Procedure:** If any individual believes there has been a violation of this chapter, he/she may file a complaint with the City's Human Rights Commission. The complaint must be filed within 180 calendar days from the date of the individual's knowledge of the allegedly discriminatory action or 180 calendar days from the date when the individual should have known of the allegedly discriminatory action. A complaint that is not filed within this timeframe cannot be considered by the Human Rights Commission. To file a complaint, first complete the complaint form, which is available at [www.a2gov.org/humanrights](http://www.a2gov.org/humanrights). Then submit it to the Human Rights Commission by e-mail ([hrc@a2gov.org](mailto:hrc@a2gov.org)), by mail (Ann Arbor Human Rights Commission, PO Box 8647, Ann Arbor, MI 48107), or in person (City Clerk's Office). For further information, please call the commission at 734-794-6141 or e-mail the commission at [hrc@a2gov.org](mailto:hrc@a2gov.org).

**Private Actions For Damages or Injunctive Relief:** To the extent allowed by law, an individual who is the victim of discriminatory action in violation of this chapter may bring a civil action for appropriate injunctive relief or damages or both against the person(s) who acted in violation of this chapter

THIS IS AN OFFICIAL GOVERNMENT NOTICE AND  
MUST BE DISPLAYED WHERE EMPLOYEES CAN READILY SEE IT.



**CITY OF ANN ARBOR  
PREVAILING WAGE DECLARATION OF COMPLIANCE**

The "wage and employment requirements" of Section 1:320 of Chapter 14 of Title I of the Ann Arbor City Code mandates that the city not enter any contract, understanding or other arrangement for a public improvement for or on behalf of the city unless the contract provides that all craftsmen, mechanics and laborers employed directly on the site in connection with said improvements, including said employees of subcontractors, shall receive the prevailing wage for the corresponding classes of craftsmen, mechanics and laborers, as determined by statistics for the Ann Arbor area compiled by the United States Department of Labor. Where the contract and the Ann Arbor City Code are silent as to definitions of terms required in determining contract compliance with regard to prevailing wages, the definitions provided in the Davis-Bacon Act as amended (40 U.S.C. 278-a to 276-a-7) for the terms shall be used. Further, to the extent that any employees of the contractor providing services under this contract are not part of the class of craftsmen, mechanics and laborers who receive a prevailing wage in conformance with section 1:320 of Chapter 14 of Title I of the Code of the City of Ann Arbor, employees shall be paid a prescribed minimum level of compensation (i.e. Living Wage) for the time those employees perform work on the contract in conformance with section 1:815 of Chapter 23 of Title I of the Code of the City of Ann Arbor.

At the request of the city, any contractor or subcontractor shall provide satisfactory proof of compliance with this provision.

The Contractor agrees:

- (a) To pay each of its employees whose wage level is required to comply with federal, state or local prevailing wage law, for work covered or funded by this contract with the City,
- (b) To require each subcontractor performing work covered or funded by this contract with the City to pay each of its employees the applicable prescribed wage level under the conditions stated in subsection (a) or (b) above.
- (c) To provide to the City payroll records or other documentation within ten (10) business days from the receipt of a request by the City.
- (d) To permit access to work sites to City representatives for the purposes of monitoring compliance, and investigating complaints or non-compliance.

The undersigned states that he/she has the requisite authority to act on behalf of his/her employer in these matters and has offered to provide the services in accordance with the terms of the wage and employment provisions of the Chapter 14 of the Ann Arbor City Code. The undersigned certifies that he/she has read and is familiar with the terms of Section 1:320 of Chapter 14 of the Ann Arbor City Code and by executing this Declaration of Compliance obligates his/her employer and any subcontractor employed by it to perform work on the contract to the wage and employment requirements stated herein. The undersigned further acknowledges and agrees that if it is found to be in violation of the wage and employment requirements of Section 1:320 of the Chapter 14 of the Ann Arbor City Code it shall be deemed a material breach of the terms of the contract and grounds for termination of same by the City.

Applied Handling Inc  
Company Name  
Marianne DePoole 5/7/2021  
Signature of Authorized Representative Date  
MARIANNE DePOOLE, Gen Mgr  
Print Name and Title  
15200 Century Dr DBN MI 48120  
Address, City, State, Zip  
313-457-1114  
Phone/Email address

Questions about this form? Contact Procurement Office City of Ann Arbor Phone: 734/794-6500

**CITY OF ANN ARBOR  
LIVING WAGE ORDINANCE**

**RATE EFFECTIVE APRIL 30, 2021 - ENDING APRIL 29, 2022**

**\$14.05 per hour**

If the employer provides health care benefits\*

**\$15.66 per hour**

If the employer does **NOT** provide health care benefits\*

Employers providing services to or for the City of Ann Arbor or recipients of grants or financial assistance from the City of Ann Arbor for a value of more than \$10,000 in a twelve-month period of time must pay those employees performing work on a City of Ann Arbor contract or grant, the above living wage.

## **ENFORCEMENT**

The City of Ann Arbor may recover back wages either administratively or through court action for the employees that have been underpaid in violation of the law. Persons denied payment of the living wage have the right to bring a civil action for damages in addition to any action taken by the City.

Violation of this Ordinance is punishable by fines of not more than \$500/violation plus costs, with each day being considered a separate violation. Additionally, the City of Ann Arbor has the right to modify, terminate, cancel or suspend a contract in the event of a violation of the Ordinance.

\* Health Care benefits include those paid for by the employer or making an employer contribution toward the purchase of health care. The employee contribution must not exceed \$.50 an hour for an average work week; and the employer cost or contribution must equal no less than \$1/hr for the average work week.

**The Law Requires Employers to Display This Poster Where Employees Can Readily See It.**

**For Additional Information or to File a Complaint contact  
Colin Spencer at 734/794-6500 or [cspencer@a2gov.org](mailto:cspencer@a2gov.org)**

**CITY OF ANN ARBOR  
LIVING WAGE ORDINANCE DECLARATION OF COMPLIANCE**

The Ann Arbor Living Wage Ordinance (Section 1:811-1:821 of Chapter 23 of Title I of the Code) requires that an employer who is (a) a contractor providing services to or for the City for a value greater than \$10,000 for any twelve-month contract term, or (b) a recipient of federal, state, or local grant funding administered by the City for a value greater than \$10,000, or (c) a recipient of financial assistance awarded by the City for a value greater than \$10,000, shall pay its employees a prescribed minimum level of compensation (i.e., Living Wage) for the time those employees perform work on the contract or in connection with the grant or financial assistance. The Living Wage must be paid to these employees for the length of the contract/program.

*Companies employing fewer than 5 persons and non-profits employing fewer than 10 persons are exempt from compliance with the Living Wage Ordinance. If this exemption applies to your company/non-profit agency please check here  No. of employees \_\_\_*

The Contractor or Grantee agrees:

- (a) To pay each of its employees whose wage level is not required to comply with federal, state or local prevailing wage law, for work covered or funded by a contract with or grant from the City, no less than the Living Wage. The current Living Wage is defined as \$14.05/hour for those employers that provide employee health care (as defined in the Ordinance at Section 1:815 Sec. 1 (a)), or no less than \$15.66/hour for those employers that do not provide health care. The Contractor or Grantor understands that the Living Wage is adjusted and established annually on April 30 in accordance with the Ordinance and covered employers shall be required to pay the adjusted amount thereafter to be in compliance with Section 1:815(3).

<b>Check the applicable box below which applies to your workforce</b>	
<input type="checkbox"/>	Employees who are assigned to any covered City contract/grant will be paid at or above the applicable living wage without health benefits
<input type="checkbox"/>	Employees who are assigned to any covered City contract/grant will be paid at or above the applicable living wage with health benefits

- (b) To post a notice approved by the City regarding the applicability of the Living Wage Ordinance in every work place or other location in which employees or other persons contracting for employment are working.
- (c) To provide to the City payroll records or other documentation within ten (10) business days from the receipt of a request by the City.
- (d) To permit access to work sites to City representatives for the purposes of monitoring compliance, and investigating complaints or non-compliance.
- (e) To take no action that would reduce the compensation, wages, fringe benefits, or leave available to any employee covered by the Living Wage Ordinance or any person contracted for employment and covered by the Living Wage Ordinance in order to pay the living wage required by the Living Wage Ordinance.

The undersigned states that he/she has the requisite authority to act on behalf of his/her employer in these matters and has offered to provide the services or agrees to accept financial assistance in accordance with the terms of the Living Wage Ordinance. The undersigned certifies that he/she has read and is familiar with the terms of the Living Wage Ordinance, obligates the Employer/Grantee to those terms and acknowledges that if his/her employer is found to be in violation of Ordinance it may be subject to civil penalties and termination of the awarded contract or grant of financial assistance.

\_\_\_\_\_  
Company Name

\_\_\_\_\_  
Street Address

\_\_\_\_\_  
Signature of Authorized Representative      Date

\_\_\_\_\_  
City, State, Zip

\_\_\_\_\_  
Print Name and Title

\_\_\_\_\_  
Phone/Email address



Date \_\_\_\_\_

\_\_\_\_\_  
(Name of Signatory Party) (Title)

do hereby state:

(1) That I pay or supervise the payment of the persons employed by \_\_\_\_\_ on the

(Contractor or Subcontractor) \_\_\_\_\_ that during the payroll period commencing on the

\_\_\_\_\_  
(Building or Work) \_\_\_\_\_ and ending the \_\_\_\_\_ day of \_\_\_\_\_

all persons employed on said project have been paid the full weekly wages earned, that no rebates have been or will be made either directly or indirectly to or on behalf of said \_\_\_\_\_ from the full

(Contractor or Subcontractor)

weekly wages earned by any person and that no deductions have been made either directly or indirectly from the full wages earned by any person, other than permissible deductions as defined in Regulations, Part 3, (29 C.F.R. Subtitle A), issued by the Secretary of Labor under the Copeland Act, as amended (49 Stat. 949, 63 Stat. 108, 72 Stat. 397; 76 Stat. 357; 40 U.S.C. § 3145), and described below:

\_\_\_\_\_  
\_\_\_\_\_  
\_\_\_\_\_  
\_\_\_\_\_

(2) That any payrolls otherwise under this contract required to be submitted for the above period are correct and complete; that the wage rates for laborers or mechanics contained therein are not less than the applicable wage rates contained in any wage determination incorporated into the contract; that the classifications set forth therein for each laborer or mechanic conform with the work he performed.

(3) That any apprentices employed in the above period are duly registered in a bona fide apprenticeship program registered with a State apprenticeship agency recognized by the Bureau of Apprenticeship and Training, United States Department of Labor, or if no such recognized agency exists in a State, are registered with the Bureau of Apprenticeship and Training, United States Department of Labor.

(4) That:

(a) WHERE FRINGE BENEFITS ARE PAID TO APPROVED PLANS, FUNDS, OR PROGRAMS

— In addition to the basic hourly wage rates paid to each laborer or mechanic listed in the above referenced payroll, payments of fringe benefits as listed in the contract have been or will be made to appropriate programs for the benefit of such employees, except as noted in section 4(c) below.

(b) WHERE FRINGE BENEFITS ARE PAID IN CASH

— Each laborer or mechanic listed in the above referenced payroll has been paid, as indicated on the payroll, an amount not less than the sum of the applicable basic hourly wage rate plus the amount of the required fringe benefits as listed in the contract, except as noted in section 4(c) below.

(c) EXCEPTIONS

EXCEPTION (CRAF7)	EXPLANATION

REMARKS

--

NAME AND TITLE	SIGNATURE
THE WILLFUL FALSIFICATION OF ANY OF THE ABOVE STATEMENTS MAY SUBJECT THE CONTRACTOR OR SUBCONTRACTOR TO CIVIL OR CRIMINAL PROSECUTION SEE SECTION 1007 OF TITLE 18 AND SECTION 231 OF TITLE 31 OF THE UNITED STATES CODE.	