

PLANNING AND DEVELOPMENT SERVICES STAFF REPORT

For Planning Commission Meeting of February 18, 2015

**SUBJECT: Pittsfield Retail Site Plan for City Council Approval
(3510 Washtenaw Avenue)
File No. SP14-043**

PROPOSED CITY PLANNING COMMISSION MOTION

The Ann Arbor City Planning Commission hereby recommends that the Mayor and City Council approve the Pittsfield Retail Site Plan and development agreement, subject to combination of the parcels prior to the issuance of permits.

STAFF RECOMMENDATION

Staff recommends that this petition be **approved** because it complies with all the applicable local, state, and federal laws, ordinances, standards, and regulations; the development would limit the disturbance of natural features to the minimum necessary to allow a reasonable use of the land; would not cause a public or private nuisance; and would not have a detrimental effect on public health, safety, or welfare.

STAFF REPORT

The Pittsfield Retail Site Plan was postponed by the Planning Commission at the November 5, 2014 meeting to allow the petitioner to revise plans to address concerns noted by staff regarding the Landscape and Engineering plans.

The petitioner has submitted revised plans in response to the comments received. All plan revisions deal with the proposed construction of utilities and required landscaping. The petitioner's landscape architect modified the plan to save two additional landmark trees and locate all required mitigation landscaping on the site. The dimensions and details of the bioretention islands have added to the plan and have been approved. Utility connections have been revised and approved. There have been no changes to the buildings or overall site layout.

City staff has confirmed revisions to the plan help address these concerns, as described below.

Washtenaw County Water Resources Commissioner (WCWRC) – Plan approval has been granted from the WCWRC.

Urban Forest and Natural Resources Planning Coordinator – A street tree escrow of \$1,886 is required. Petitioner is still proposing to remove a street tree for the realigned curb cut onto Pittsfield Boulevard. However, two additional landmark trees on the site have been saved with plan revisions. The petitioner's landscape architect has worked with City staff to redesign the plan, satisfy all landscaping requirements, and minimize impact to the existing vegetation on the site. Staff now supports the plan as proposed.

Systems Planning – Sanitary sewer data has been reviewed and approved. The footing drains of one home, or flow equivalent to 4.77 GPM, will need to be removed from the sanitary sewer system in order to mitigate new flow from this proposed development.

Project Management – A development agreement has been drafted in order to clear up easement language and bring the existing easements into conformance with the easement language currently used. Staff is requesting the re-dedication of the 22 foot wide existing front right-of-way easement along Washtenaw Avenue as City right-of-way. Staff is also requesting the re-dedication of easements along the alley in the rear in order to cover maintenance of public utilities and solid waste removal.

AAATA – The AAATA is considering expanding the Superstop in the Washtenaw Avenue right-of-way adjacent to this location. The petitioners and their engineer have discussed the plan with representatives of the AAATA. Any proposed improvements as the result of the Superstop will be constructed within the public right-of-way north of the site.

Prepared by Matt Kowalski
Reviewed by Wendy Rampson

Attachments: 11/5/14 Planning Staff Report
Revised Landscape Plan
Draft Development Agreement

c: Petitioner: A.F Jonna Development
4036 Telegraph, Suite 201
Bloomfield Hills, MI 48302

Petitioner's Representative: Jason Van Ryn
Nederveld
3025 Miller Road
Ann Arbor, MI 48103

City Attorney
Systems Planning
File No. SP14-043

PLANNING AND DEVELOPMENT SERVICES STAFF REPORT

For Planning Commission Meeting of November 5, 2014

**SUBJECT: Pittsfield Retail Site Plan for City Council Approval
3510 Washtenaw Avenue
File No. SP14-043**

PROPOSED CITY PLANNING COMMISSION MOTION

The Ann Arbor City Planning Commission hereby recommends that the Mayor and City Council approve the Pittsfield Retail Site Plan, subject to preliminary approval from the Washtenaw County Water Resources Commissioner prior to City Council approval, and subject to combination of the parcels prior to the issuance of permits.

STAFF RECOMMENDATION

Staff recommends that this petition be **postponed** in order to allow time for staff to review and comment on revised plans that address concerns regarding dedication and ownership of the right of way along Washtenaw Avenue and the rear alley, proposed landscape modifications, solid waste, street tree and utility engineering comments.

LOCATION

The site is located on the south side of Washtenaw Avenue, just west of Yost Street and east of Pittsfield Boulevard (South Area, Malletts Creek Watershed).

DESCRIPTION OF PETITION

The petitioner seeks to demolish the former bank building adjacent to Pittsfield Boulevard and construct single-story additions totaling 12,209 sf to connect the remaining 4 retail buildings on the site. The existing buildings total 55,285 square feet and are located on 5 separate parcels that will be combined as a condition of site plan approval. The building additions will add retail tenants and facilitate a complete façade and site upgrade.

The parking lot will be reconstructed and reconfigured, incorporating a relocated central drive aligned with the Washtenaw Avenue curb cut. Perimeter and interior landscaping will be added, as will new lighting. A total of 257 parking spaces (including 54 compact and 6 barrier-free) will be provided on the site in front of the stores and along the alley behind the stores; the site currently contains 269 parking spaces. The petitioner will install 14 Class B (covered) and 12 Class C (uncovered) bicycle parking spaces. There currently is no bicycle parking provided on site.

The plan includes adding a consistent sidewalk and some landscaping along the front of the building and two sidewalk links along the central drive, connecting the stores directly to the AAATA transit stop on Washtenaw Avenue. Sidewalk links to both Pittsfield Boulevard and Yost also will be added. A new public sidewalk will be constructed along Yost, connecting the neighborhood to the south with the sidewalk along Washtenaw Avenue.

The petitioner is proposing to convert the existing 22-foot wide service drive on the north part of the site from pavement to turf. The city is requesting that this area be re-dedicated to the City as right-of-way replacing an existing access easement. This area is directly adjacent to the Washtenaw Avenue right-of-way, which is under control of the Michigan Department of Transportation (MDOT) and currently is used as a parking lot aisle. There are no plans for right-of-way improvements along Washtenaw as part of this project. The existing curb cut onto Washtenaw will remain in the same location.

There are currently three curb cuts to Pittsfield Boulevard. One curb cut, which serviced the former bank drive-thru, will be removed and one curb cut near Washtenaw will be moved south (away from the intersection) along Pittsfield to line up with the aisle along the front of the retail center. The existing curb cut to the alley will remain. There are two curb cuts on the east side of the site leading to Yost; both will remain in their current locations.

There is a 24-foot wide easement for public right-of-way on the south part of this site, to the rear of the existing building. Due to the location of this alley easement between the commercial buildings and adjacent residential uses, a conflicting land use buffer is not required. However, the petitioner has agreed to remove the existing deteriorated fence and replace it with a new privacy fence between the adjacent residential properties and this site.

The stormwater treatment system is under the jurisdiction of the Washtenaw County Water Resources Commissioner (WCWRC). This treatment will be provided using a series of underground pipes and bioswales located within the parking lot. First flush, bankfull and 100-year storm detention are all provided onsite as required by City Code. The approval of the WCWRC will be required before this plan will be placed on a City Council agenda. New bioswales will be added to the parking lot and planted with native vegetation, including trees, and will also act as the required interior parking lot landscaping. There currently is no stormwater treatment for the site.

There are eight landmark trees on the site; seven will be removed and one will be impacted by proposed construction. The proposed mitigation plan is still under review by City Staff.

As required by the Citizen Participation Ordinance, the petitioner mailed out postcard notification to owners and occupants within 500 feet of the site. Staff has received a letter from the adjacent Pittsfield Village complex, which is included in the packet. No other feedback was received from the public in regards to this petition.

SURROUNDING LAND USES AND ZONING

	LAND USE	ZONING
NORTH	Commercial	C3 (Fringe Commercial District)
EAST	Commercial	C3 (Fringe Commercial District)
SOUTH	Single-Family Residential	R1C (Single-Family Dwelling District)
WEST	Commercial	C3 (Fringe Commercial District)

COMPARISON CHART

		EXISTING	PROPOSED	REQUIRED
Zoning		C3 Fringe Commercial District	C3 Fringe Commercial District	C3 Fringe Commercial District
Gross Lot Area		241,437 sq ft (5.5 acres)	241,437 sq ft (5.5 acres)	6,000 sq ft MIN
Floor Area in % of Lot Area		23% (55,285 sf)	30% (71,494 sf)	200% (159,824 sf) MAX
Setbacks	Front	172 ft (Washtenaw) 62 ft (Yost) 49ft (Pittsfield)	172 ft (Washtenaw) 10 ft (Yost) 10 ft(Pittsfield)	10 ft MIN 25ft MAX (at least one frontage on corner lot)
	Side(s)	N/A	N/A	0 ft MIN
	Rear	34 ft	34 ft	0 ft MIN
Height		26 ft 2 in/1 story	27 ft 6 in/1 story	55 ft/4 stories MAX
Parking - Automobiles		269 spaces	257 total spaces: <ul style="list-style-type: none"> • 197 regular • 54 compact • 6 barrier-free 	237 MIN; 277 MAX
Parking – Bicycles		None	14 spaces – Class B 12 spaces – Class C	12 spaces – Class B MIN 12 spaces – Class C MIN

HISTORY

The existing retail center was constructed in the 1950's before site plans were required. A small addition at the rear of the easternmost building was approved and constructed in 1979. A site plan was approved in 1999 for a 2,790 square foot greenhouse addition in the area of the current canopy. This greenhouse was never constructed. In 2011, a site plan was approved to demolish the existing canopy on the east site of the site and construct a 9,500 building addition. The addition was never constructed and the site plan expired October 3, 2014.

PLANNING BACKGROUND

The Master Plan: Land Use Element identifies this parcel as part of the South Area and recommends continued commercial uses. The Land Use Element also includes design recommendations for retail centers, including the use of masonry, building awnings, extensive landscaping, minimized vehicular parking, non-motorized connections and amenities, reduced setbacks along the street, and the opportunity for mixed uses (flex space).

The Non-motorized Plan recommends bicycle lanes and a sidewalk/walkway along this segment of Washtenaw Avenue, in addition to non-motorized facilities underneath the US-23 overpass, connecting to Pittsfield Township. The MDOT non-motorized improvement project to provide a

connection under US-23 was constructed in 2012. The petitioner will provide new public sidewalks along the Yost Boulevard and Washtenaw Avenue frontages as part of this project.

The Washtenaw Avenue Corridor Redevelopment Strategy recommends pedestrian and transit-friendly redevelopment along this segment of Washtenaw Avenue. An AAATA “SuperStop” was installed in the MDOT right-of-way at the northwest corner of the shopping center, near Pittsfield Boulevard.

The recently completed Reimagine Washtenaw Corridor Improvement Study recommends a 144 foot right-of-way in this segment to accommodate a variety of transportation facilities and services. Future facilities should include 6 foot wide sidewalks, 8 foot wide landscape buffers and a 8 foot wide dedicated bike lane. The study also recommends wider landscaped medians at key priority intersections, such as Yost and Pittsfield.

STAFF COMMENTS

Ann Arbor Area Transportation Authority - The AATA is considering expanding the Superstop on Washtenaw in front of this site. The additional right-of-way along Washtenaw could be used for expansion and the provision of passenger amenities.

Systems Planning – Sanitary sewer calculations are still under review. Staff is requesting the dedication of the 22 foot wide existing front right-of-way easement as City right-of-way along Washtenaw Avenue. The City Attorney’s Office is evaluating the existing right-of-way agreement for the rear alley with respect to utilities and boundaries.

Urban Forest and Natural Resources Planning Coordinator – A street tree escrow of \$1,886 is required. Petitioner is proposing to remove a street tree for the realigned curb cut onto Pittsfield Boulevard. Forestry does not support the removal of this tree. Revisions are needed to the landmark tree mitigation plans.

Washtenaw County Water Resources Commissioner (WCWRC) – Plans have been re-submitted to the WCWRC for review. Preliminary plan approval is required from the WCWRC before City Council approval.

Planning – The petition is consistent with Master Plan recommendations for the redevelopment of retail centers along transit routes, minimizing excess parking and increasing pedestrian connections with existing neighborhoods and transit stops. The site plan will be a significant upgrade to the site, providing stormwater treatment, bicycle parking, increased landscaping and architectural improvements to the existing buildings. In coordination with the Reimagine Washtenaw Corridor Improvement Study, the rededication of the right-of-way along Washtenaw can be used to assist in achieving the goals of this planning process. The conditions of the existing right-of-way over the property are insufficient to address the current requirements of the City and future corridor plans.

Prepared by Matt Kowalski
Reviewed by Wendy Rampson
10/31/14

Attachments: Parcel/Zoning Map
Aerial Photo
Site Plan
Landscape Plan
Elevations

c: Petitioner: A.F Jonna Development
4036 Telegraph, Suite 201
Bloomfield Hills, MI 48302

Petitioner's Representative: Jason Van Ryn
Nederveld
3025 Miller Road
Ann Arbor, MI 48103

City Attorney
Systems Planning
File No. SP14-043

Pittsfield Retail Center -Zoning Map-

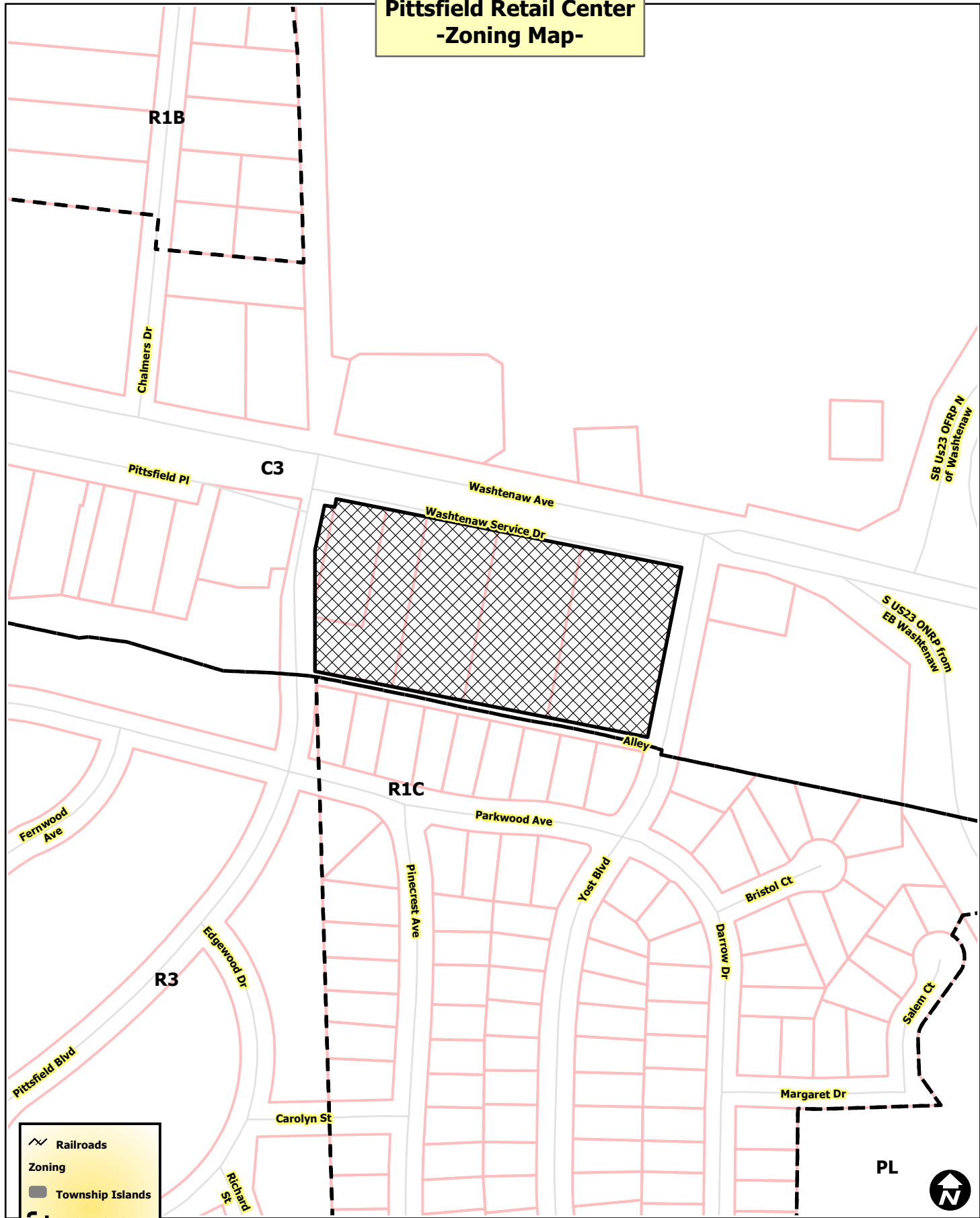



	Railroads
Zoning	
	Township Islands
	Zoning Districts
	Parcels
	Huron River



City of Ann Arbor Map Disclaimer:
 No part of this product shall be reproduced or transmitted in any form or by any means, electronic or mechanical, for any purpose, without prior written permission from the City of Ann Arbor.
 This map complies with National Map Accuracy Standards for mapping at 1 Inch = 100 Feet. The City of Ann Arbor and its mapping contractors assume no legal representation for the content and/or inappropriate use of information on this map.
 Map Created: 7/25/2014

Pittsfield Retail Center -Aerial Map-





-  Railroads
-  Parcels
-  Huron River



City of Ann Arbor Map Disclaimer:
 No part of this product shall be reproduced or transmitted in any form or by any means, electronic or mechanical, for any purpose, without prior written permission from the City of Ann Arbor.
 This map complies with National Map Accuracy Standards for mapping at 1 Inch = 100 Feet. The City of Ann Arbor and its mapping contractors assume no legal representation for the content and/or inappropriate use of information on this map.
 Map Created: 7/25/2014

Pittsfield Retail Center -Aerial Map-



-  Railroads
-  Parcels
-  Huron River



City of Ann Arbor Map Disclaimer:
 No part of this product shall be reproduced or transmitted in any form or by any means, electronic or mechanical, for any purpose, without prior written permission from the City of Ann Arbor.
 This map complies with National Map Accuracy Standards for mapping at 1 Inch = 100 Feet. The City of Ann Arbor and its mapping contractors assume no legal representation for the content and/or inappropriate use of information on this map.
 Map Created: 7/25/2014

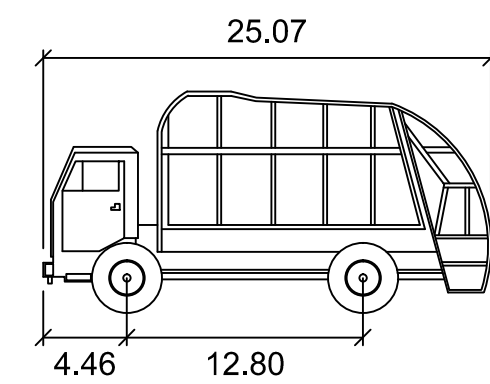

2MU feet
 Width : 8.20
 Track : 8.20
 Lock to Lock Time : 6.0
 Steering Angle : 40.8

LEGEND

- EX. BITUMINOUS
- PROP. BITUMINOUS
- PROP. CONCRETE
- EX. CONCRETE

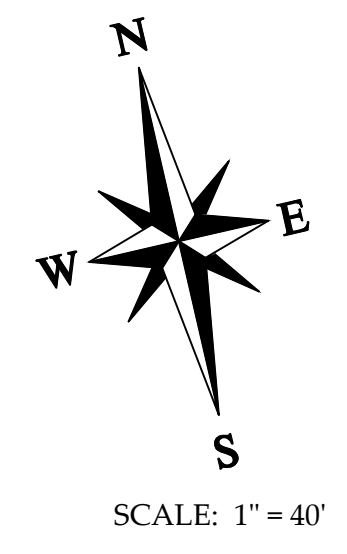

- ### SITE PLAN NOTES
- BUILDING ADDRESS SHALL BE CLEARLY VISIBLE WHEN APPROACHING THE BUILDING. ADDRESS NUMBERS SHALL BE PROVIDED ON ALL SOUTH ALLEY DOORS.
 - THE OWNER WILL CONTINUE A PRIVATE SERVICE FOR SOLID WASTE COLLECTION. GARBAGE AND RECYCLING BINS WILL BE LOCATED WITHIN THE NEW DUMPSTER ENCLOSURE LOCATED AT THE CENTER REAR OF THE PROPOSED BUILDING.
 - SIDEWALKS ARE TO BE KEPT AND MAINTAINED IN GOOD REPAIR BY THE OWNER OF THE LAND ADJACENT TO AND ABUTTING THE SAME, PRIOR TO ISSUANCE OF THE FINAL CERTIFICATE OF OCCUPANCY FOR THIS SITE. ALL EXISTING SIDEWALKS IN NEED OF REPAIR MUST BE REPAIRED IN ACCORDANCE WITH THE CITY STANDARDS.
 - ANY SIDEWALK OR RAMP CONSTRUCTED WITHIN THE PUBLIC RIGHT-OF-WAY SHALL MEET ALL REQUIREMENTS AS SET FORTH IN THE ADA STANDARDS FOR ACCESSIBLE DESIGN.
 - SITE DIMENSIONS ARE TO FACE OF CURB OR FACE OF WALK, UNLESS OTHERWISE NOTED.
 - THE CONSTRUCTION OF THE SITE WILL BEGIN IMMEDIATELY PENDING CITY APPROVALS AND PERMITS. THE PROJECT WILL BE COMPLETED IN 2015.
 - THE PROJECT WILL BE COMPLETED IN 1 PHASE.
 - THE PROPOSED PROJECT IS NOT LOCATED WITHIN THE 100 YEAR FLOOD PLAIN.

- ### CONSTRUCTION NOTES
- ALL CONSTRUCTION AND MATERIAL SPECIFICATIONS INCLUDING FOR THIS PROJECT SHALL BE IN ACCORDANCE WITH THE MOST CONSTRUCTION AND MATERIALS SPECIFICATIONS (LATEST EDITION) AND THE ORDINANCES OF THE CITY. WHERE CONFLICTS OCCUR IN THE ABOVE, THE CITY SHALL BE THE GOVERNING AUTHORITY.
 - SOIL BORINGS HAVE BEEN PERFORMED BY THE DEVELOPER AND SHALL BE PROVIDED TO THE CONTRACTOR. VARIATION IN EXISTING SOIL CONDITIONS MAY IMPACT THE EARTHWORK QUANTITIES IF UNSATISFACTORY SOILS ARE ENCOUNTERED DURING CONSTRUCTION.
 - THE CONTRACTOR SHALL BE RESPONSIBLE FOR ALL DAMAGES TO THE EXISTING WATER AND SEWERAGE SYSTEM RESULTING FROM NON-COMFORMANCE WITH THE APPLICABLE STANDARDS OR THROUGH GENERAL NEGLIGENCE.
 - ALL WORK, INCLUDING INSPECTIONS AND TESTING COST REQUIRED FOR REMOVAL, RELOCATION OR NEW CONSTRUCTION FOR PRIVATE OR PUBLIC UTILITIES, WILL BE DONE BY AND AT THE EXPENSE OF THE CONTRACTOR AND INCLUDED IN THE BID PRICE FOR THE VARIOUS WORK ITEMS UNLESS OTHERWISE NOTED. THE CONTRACTOR SHALL BE RESPONSIBLE FOR OBTAINING AND PAYING FOR ALL NECESSARY PERMITS FROM THE CITY AND ANY OTHER AGENCY FOR ALL WORK DONE BY THE CONTRACTOR.
 - ANY DEFECTS IN THE CONSTRUCTION, INCLUDING MATERIALS OR WORKMANSHIP, SHALL BE REPLACED OR CORRECTED BY REMOVAL AND REPLACEMENT OR OTHER APPROVED METHODS PRIOR TO ACCEPTANCE BY THE CITY OR OWNER WITHOUT ANY ADDITIONAL COST TO THE CITY OR OWNER.
 - ALL LAWN AREAS REMOVED OR DISTURBED SHALL BE REPLACED WITH TOPSOIL AND SOIL WHERE RESEED AND MULCH IS RESEED AND MULCH IS SATISFACTORY RE-ESTABLISHMENT OF LAWN DOES NOT OCCUR.
 - ALL PUNCH LIST AND DEFICIENCY WORK SHALL BE COMPLETED WITHIN 1 YEAR OF THE END OF CONSTRUCTION.
 - THE CONTRACTOR SHALL OBTAIN A STREET OPENING PERMIT FROM THE CITY BEFORE BEGINNING WORK WITHIN ANY PUBLIC STREET RIGHT-OF-WAY.
 - THE CONTRACTOR SHALL MAINTAIN A CURRENT SET OF CONSTRUCTION DRAWINGS ON SITE AT ALL TIMES.
 - THESE PLANS HAVE BEEN DEVELOPED FOR ELECTRONIC FIELD LAYOUT. DIMENSIONS SHOWN ARE FOR GRAPHIC REPRESENTATION ONLY AND SHOULD NOT BE USED FOR LAYOUT. CONTACT THE ENGINEER IF ANY DISCREPANCIES BETWEEN THE PLAN AND ELECTRONIC DATA ARE DISCOVERED.
 - THE WORK LIMITS SHOWN ON THESE PLANS ARE FOR PHYSICAL CONSTRUCTION ONLY. THE CONTRACTOR SHALL PROVIDE ALL NECESSARY LIGHTS, BARRICADES, FLAGMEN, ETC. AS REQUIRED TO PERFORM THE REQUIRED WORK. THE INSTALLATION AND OPERATION OF ALL TEMPORARY TRAFFIC CONTROL AND TEMPORARY TRAFFIC CONTROL DEVICES AS REQUIRED SHALL BE PROVIDED BY THE CONTRACTOR WHETHER INSIDE OR OUTSIDE THESE WORK LIMITS. THE CONTRACTOR SHALL FURNISH, ERECT, MAINTAIN AND SUBSEQUENTLY REMOVE SUCH ADDITIONAL TRAFFIC CONTROL DEVICES LOCATED OUTSIDE THE LIMITS OF CONSTRUCTION AS ARE REQUIRED ON AREAS WHICH ARE USED AS DETOURS, INCLUDING "ROAD CLOSED" SIGNS AND BARRICADES AT THE POINT WHERE THE ROAD IS CLOSED TO THROUGH TRAFFIC.
 - THE CONTRACTOR SHALL PROTECT LOCATION OF ALL PROPERTY PINS AND BENCHMARKS.
 - ALL WORK CONTEMPLATED SHALL AT ALL TIMES BE SUBJECT TO THE DIRECT INSPECTION OF THE CITY, OWNER AND THEIR REPRESENTATIVES. THE CITY AND OWNER RESERVES THE RIGHT TO HALT ALL CONSTRUCTION ACTIVITY FOR NON-COMFORMANCE OF PLANS, SPECIFICATIONS AND OTHER APPLICABLE STANDARDS OR REGULATIONS.
 - PRICES BID PER FOOT FOR ALL PIPES IS COMPACTED IN PLACE REGARDLESS OF SOIL OR ROCK CONDITIONS.
 - CONTRACTOR IS RESPONSIBLE FOR ALL SIGNS, BARRICADES AND SAFETY FENCES TO DETER PLEOPLE FROM THE WORK AREA AND FOR MAINTAINING AND PROTECTING THE FLOW OF VEHICULAR AND PEDESTRIAN TRAFFIC AROUND THE JOB SITE. TRAFFIC CONTROLS SHALL BE COORDINATED WITH THE POLICE DEPARTMENT AND THE CITY.
 - PRIOR TO ANY CONSTRUCTION OR GRADING, A PROTECTIVE BARRIER, FENCE, POST AND/OR SIGNS CLEARLY INDICATING LIMITS OF WORK/DISTURBANCE SHALL BE INSTALLED INDICATING NO REPAIRS, REMOVAL OR DISTURBANCES OUTSIDE LIMITS. THE CITY AND OWNER SHALL BE CONTACTED UPON DETERMINATION OF LIMITS IN THE FIELD.
 - ALL ROAD SURFACES, EASEMENTS OR RIGHT-OF-WAYS DISTURBED BY CONSTRUCTION OF ANY PART OF THIS IMPROVEMENT ARE TO BE RESTORED COMPLETELY TO THE SATISFACTION OF THE CITY AND THE OWNER.
 - NO PARKING OF CONTRACTOR OR CONTRACTOR EMPLOYEE'S VEHICLES ON ANY PUBLIC STREETS SHALL BE PERMITTED.
 - ALL DISTURBED SIGNS, GUARDRAILS, MAIL BOXES, AND DRIVEWAYS SHALL BE REPAIRED OR REPLACED AS DIRECTED BY THE CITY AND THE OWNER.
 - DUST CONTROL: THE CONTRACTOR SHALL SUPPLY ALL LABOR, MATERIALS, AND EQUIPMENT NECESSARY SUCH AS CALCIUM CHLORIDE, WATER OR A MOTORIZED DUST-FREE STREET SWEEPING DEVICE TO MAINTAIN ALL ROADWAYS USED FOR ACCESS TO THE CONSTRUCTION SITE AND SHALL ADHERE TO ALL ORDINANCES OF THE CITY, COUNTY, MDIRE OR ANY OTHER GOVERNING AUTHORITY.
 - ALL SEWERS, MANHOLES, JUNCTION CHAMBERS AND INLET BASINS MUST BE CLEANED BEFORE ACCEPTANCE BY THE CITY AND THE OWNER.
 - IF MUD, SOIL OR OTHER DEBRIS IS DEPOSITED ON ADJACENT STREETS, ROADS OR OTHER PROPERTY, THE CONTRACTOR SHALL BE RESPONSIBLE FOR THE REMOVAL OF SUCH AT THE END OF EACH WORK DAY OR AS REQUIRED DURING THE WORK DAY.
 - ADJUST TO GRADE OR RECONSTRUCT TO GRADE WORK SHALL INCLUDE THE REMOVAL AND REPLACEMENT OF ANY EXISTING CONCRETE BLOCKOUT PAVEMENT, DAMAGED PAVEMENT DOWNELS OR OTHER SUCH LOAD TRANSFERS DEVICES SHALL BE REPLACED AS DIRECTED BY THE CITY AND THE ENGINEER.
 - ALL EXISTING CASTINGS FOR STRUCTURES TO BE ADJUSTED OR RECONSTRUCTED TO GRADE SHALL BE FIELD CHECKED AT THE TIME OF CONSTRUCTION AND MARKED SUITABLE FOR SALVAGE AND REUSE OR REPLACED.
 - COMPACTED PREMIUM BACKFILL (MOT CLASS II SAND) WILL BE REQUIRED AT ALL FILL AREAS OR ANY STREETS WHERE REMOVAL AND REPLACEMENT OF PAVEMENT IS REQUIRED AND FOR ALL UNDERGROUND CONSTRUCTION UNDER ANY DRIVEWAY OR PAVEMENT INCLUDING THE 45 DEGREE ANGLE OF INFLUENCE FROM THE OUTSIDE EDGE OF PAVEMENT OR TOP OF CURB. COMPACTION TESTS SHALL BE REQUIRED EVERY 50 FEET UNDER PAVEMENT. PAVEMENT INCLUDES, BUT NOT LIMITED TO, ROADWAY SURFACES, SIDEWALKS, BIKE WAYS, DRIVEWAYS, SHOULDERS, BUILDINGS, ETC.
 - NO BUILDING MATERIAL, EQUIPMENT, VEHICLES OR CHEMICALS SHALL BE STORED OR PLACED OUTSIDE LIMITS OF WORK/DISTURBANCE.
 - STORMWATER POLLUTION PREVENTION ITEMS SHALL BE IN PLACE PRIOR TO COMMENCING CLEARING OPERATIONS, EARTHWORK GRADING, OR ANY OTHER TYPE OF CONSTRUCTION ACTIVITY.
 - ROOF DRAINS, FOUNDATION DRAINS AND OTHER CLEAN WATER CONNECTIONS TO THE SANITARY SEWER ARE PROHIBITED.

www.nederveld.com
800.222.1868

ANN ARBOR
3025 Miller Road
Ann Arbor, MI 48103
PHONE: 734.928.6963

CHICAGO
1082 National Parkway
Schaumburg, IL 60173
PHONE: 312.578.3897

COLUMBUS
6355 Old Avery Road, Suite A
Dublin, OH 43016
PHONE: 614.899.1127

GRAND RAPIDS
217 Grandville Ave., Suite 302
Grand Rapids, MI 49503
PHONE: 616.575.5190

HOLLAND
347 Hoover Boulevard
Holland, MI 49423
PHONE: 616.358.0949

INDIANAPOLIS
8459 Castlewood Dr., Suite B
Indianapolis, IN 46250
PHONE: 317.286.3762

Site Layout Plan

PITTSFIELD RETAIL

PART OF THE NE 1/4 OF SECTION 2, T3S, R6E,
CITY OF ANN ARBOR, WASHTENAW COUNTY, MICHIGAN

A.F. JONNA DEVELOPMENT

Attention: A.F. Jonna

4036 Telegraph Road, STE 201
Bloomfield Hills, MI
Phone: (248) 593-6200

no.	date	checked	comment
1	07/28/14	JYR	SITE PLAN SUBMITTAL TO CITY OF ANN ARBOR AND WCVRC
2	09/24/14	JYR	SITE PLAN RE-SUBMITTAL TO CITY OF ANN ARBOR AND WCVRC
3	10/29/14	JYR	SITE PLAN RE-SUBMITTAL TO CITY OF ANN ARBOR AND WCVRC
4			
5			
6			
7			
8			

date: 07/28/14
drawn by: BK
checked by: JYR

project no.: 14500104

C-205

sheet no.: 4 OF 21

© 2014 Nederveld, Inc.

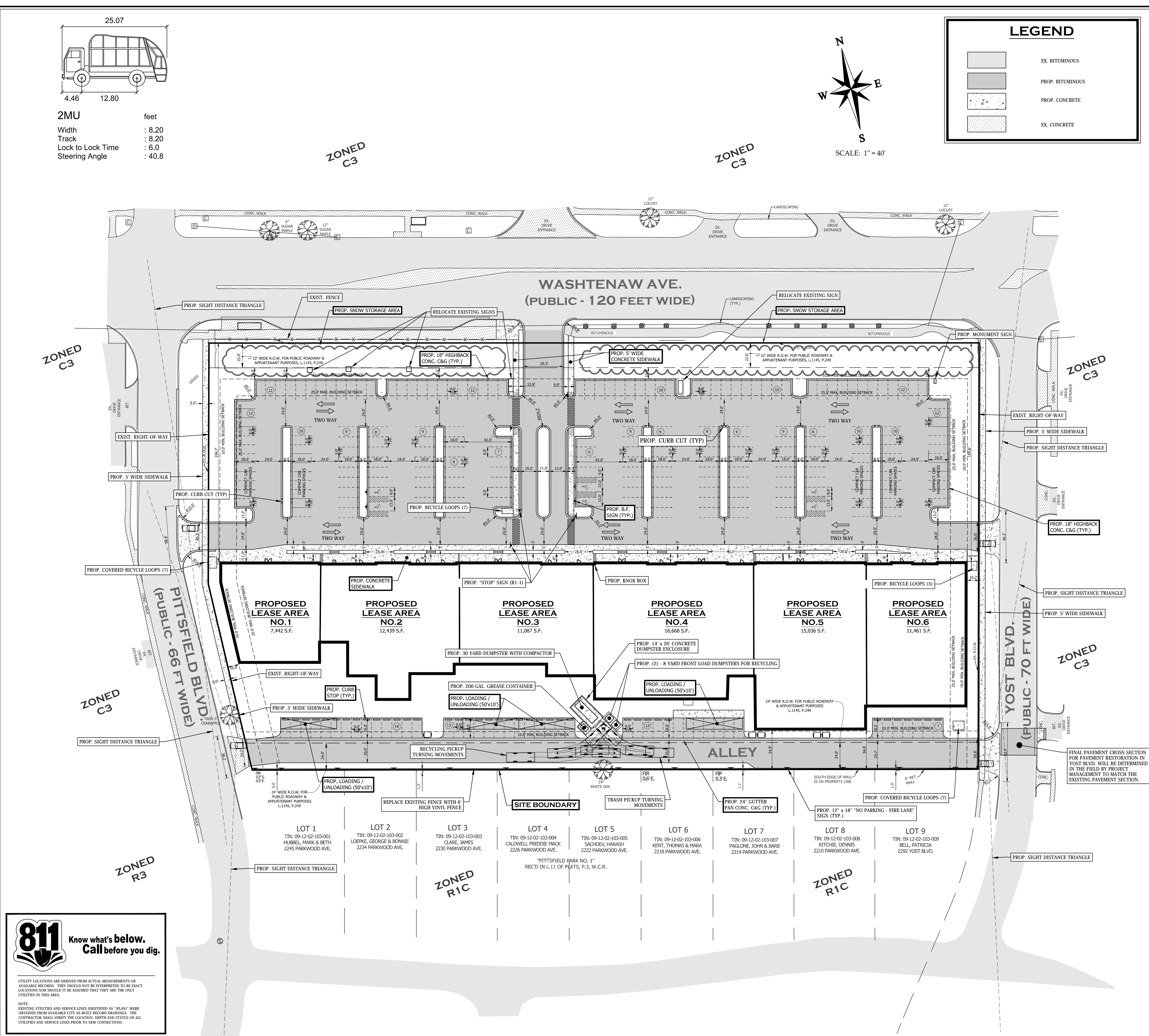

Know what's below.
Call before you dig.

UTILITY LOCATIONS ARE DERIVED FROM ACTUAL MEASUREMENTS OR AVAILABLE RECORDS. THEY SHOULD NOT BE INTERPRETED TO BE EXACT LOCATIONS NOR SHOULD IT BE ASSUMED THAT THEY ARE THE ONLY UTILITIES IN THIS AREA.

NOTE: EXISTING UTILITIES AND SERVICE LINES IDENTIFIED AS "PLANS" WERE OBTAINED FROM AVAILABLE CITY AS-BUILT RECORD DRAWINGS. THE CONTRACTOR SHALL VERIFY THE LOCATION, DEPTH AND STATUS OF ALL UTILITIES AND SERVICE LINES PRIOR TO NEW CONNECTIONS.

seal:

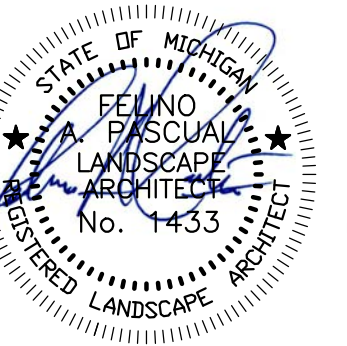

client:
A.F. JONNA
Development and Management Co.
 4036 Telegraph Road, suite 201
 Bloomfield Hills, Michigan 48302
 ph. (248) 593-6200

project:
PITTSFIELD
RETAIL

project location:
 Washtenaw Ave., Yost
 Blvd. & Pittsfield Blvd.

City of Ann Arbor,
 Michigan

sheet title:
Landscape Plan

job no. / issue / revision date:
 LS14.070.07/SPA/7-27-2014
 LS14.070.09/SPA/9-24-2014
 LS14.070.10/SPA/10-29-2014

drawn by:
JP, CZ
 checked by:
FP
 date:
7-19-2014
 notice:
 Copyright © 2014
 This document and the subject matter contained therein is proprietary and is not to be used or reproduced without the written permission of Felino Pascual and Associates

Do Not scale drawings. Use figured dimensions only
 project no:
LS14.070.07
 sheet no:

Washtenaw Avenue

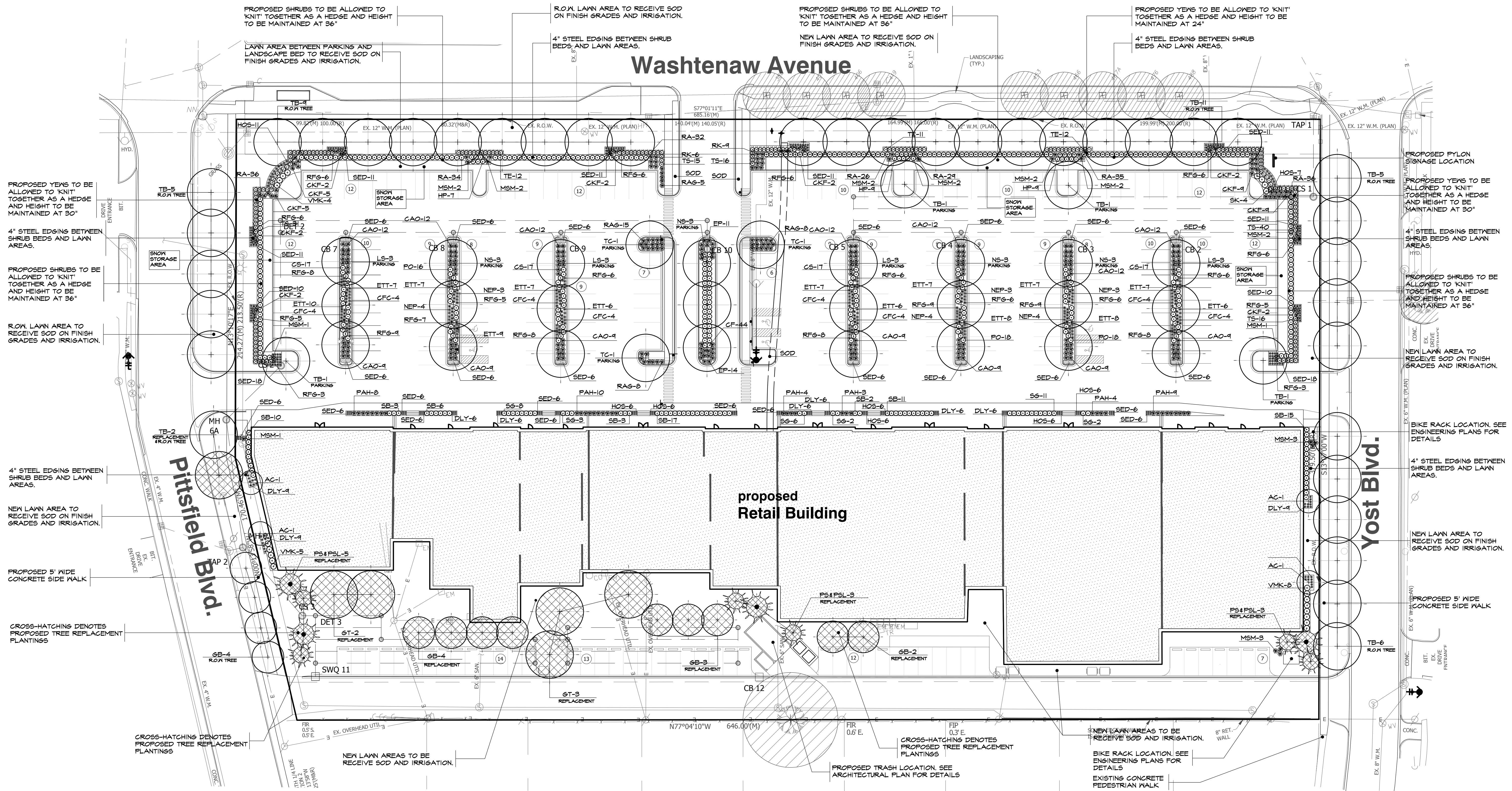

general landscape notes:

- LANDSCAPE CONTRACTOR SHALL VISIT THE SITE, INSPECT EXISTING CONDITIONS, REVIEW PROPOSED PLANTINGS AND RELATED WORK. CONTACT THE OWNER AND/OR LANDSCAPE ARCHITECT WITH ANY CONCERNS OR DISCREPANCY BETWEEN THE PLAN, PLANT MATERIAL LIST, AND/OR SITE CONDITIONS.
- PRIOR TO BEGINNING OF CONSTRUCTION ON ANY WORK, CONTRACTORS SHALL VERIFY LOCATIONS OF ALL ON SITE UTILITIES, GAS, ELECTRIC, TELEPHONE, CABLE TO BE LOCATED BY CONTACTING MISS DIG 1-800-482-7171. ANY DAMAGE OR INTERRUPTION OF SERVICES SHALL BE THE RESPONSIBILITY OF THE CONTRACTOR. COORDINATE ALL RELATED WORK ACTIVITIES WITH OTHER TRADES AND REPORT ANY UNACCEPTABLE JOB CONDITIONS TO OWNER PRIOR TO COMMENCING.
- NUMERICAL VALUE ON THE LANDSCAPE QUANTITIES SPECIFIED ON THE PLAN TAKE PRECEDENCE OVER GRAPHIC REPRESENTATION. VERIFY ANY CONCERN/DISCREPANCY WITH LANDSCAPE ARCHITECT.
- PLANT MATERIAL LOCATION CANNOT BE CHANGED WITHOUT APPROVAL FROM THE CITY OF ANN ARBOR AND LANDSCAPE ARCHITECT.
- ALL SUBSTITUTIONS OR DEVIATIONS FROM THE LANDSCAPE PLAN ARE NOT PERMITTED WITHOUT APPROVAL FROM THE CITY OF ANN ARBOR AND LANDSCAPE ARCHITECT.
- ALL LARGE TREES AND EVERGREENS TO BE STAKED, GUYED AND WRAPPED AS DETAIL SHOWN ON PLAN. STAKING MUST BE REMOVED NO LATER THAN ONE YEAR AFTER PLANTING. TREES SHOULD ONLY BE STAKED IF THEY ARE GREATER THAN 3" CALIPER OR ON A WINDY SITE.
- PLANT BEDS TO BE DRESSED WITH MIN. 3" OF FINELY DOUBLE SHREDDED HARBARK MULCH.
- DIG SHRUB PITS 1' LARGER THAN SHRUB ROOT BALLS AND TREE PITS 2' LARGER THAN ROOT BALL. BACK FILL WITH ONE PART TOP SOIL AND ONE PART SOIL FROM EXCAVATED PLANTING HOLE.
- REMOVE ALL TWINE, WIRE AND BURLAP FROM TREE AND SHRUB EARTH BALLS, AND FROM TREE TRUNKS.
- NATURAL COLOR, FINELY SHREDDED HARDWOOD BARK MULCH REQUIRED FOR ALL PLANTINGS. 4" THICK BARK MULCH FOR TREES IN 4" DIA. CIRCLE WITH 3" PULLED AWAY FROM TRUNK. 3" THICK BARK MULCH FOR SHRUBS AND 2" THICK BARK MULCH FOR PERENNIALS.
- PLANT MATERIAL QUALITY & INSTALLATION SHALL BE IN ACCORDANCE WITH THE CURRENT AMERICAN ASSOCIATION OF NURSERYMEN LANDSCAPE STANDARDS.
- PROVIDE PEAT SOD FOR ALL NEW AND DISTURBED LAWN AREAS UNLESS NOTED OTHERWISE.
- ALL PLANTING AREAS TO BE PREPARED WITH APPROPRIATE SOIL MIXTURES AND FERTILIZER BEFORE PLANT INSTALLATION.
- PLANT TREES AND SHRUBS GENERALLY NO CLOSER THEN THE FOLLOWING DISTANCES FROM SIDEWALKS, CURBS AND PARKING STALLS:
 - SHADE TREES _____ 5 FT.
 - ORNAMENTAL AND EVERGREEN TREES (CRAB PINE, SPRUCE, ETC.) _____ 10 FT.
 - SHRUBS THAT ARE LESS THAN 1 FOOT TALL AND WIDE AT MATURITY. _____ 2 FT.
- NO TREES OR EVERGREENS TO BE INSTALLED OVER ANY PROPOSED OR EXISTING UTILITY LINES AS SHOWN ON THE OVERALL LANDSCAPE PLAN. SEE ENGINEERING PLANS FOR EXACT LOCATION AND DETAILS.
- ALL LAWN AREAS AND LANDSCAPE BEDS TO BE FULLY IRRIGATED WITH A AUTOMATIC UNDERGROUND SYSTEMS. IRRIGATION SYSTEM TO HAVE SEPARATE ZONES FOR LAWN AREAS, PARKING ISLANDS, AND SHRUB BEDS WITH DIFFERENT CONTROL MOISTURE LEVEL ADJUSTMENT PER ZONE AS REQUIRED. IRRIGATION PLAN TO BE PROVIDED AT LATER DATE.
- UNLESS NOTED OTHERWISE, LANDSCAPE BEDS ADJACENT TO LAWN TO RECEIVE EDGINGS. EDGINGS SHALL BE 4" X 1/8" METAL (FINISH BLACK OR GREEN) OR APPROVED EQUAL AND TO BE INSTALLED WITH HORIZONTAL METAL STAKES AT 32" O.C. OR PER MANUFACTURER'S SPECIFICATION.
- ALL LANDSCAPE BEDS ADJACENT AND NEXT TO BUILDING SHALL BE EXCAVATED OF ALL BUILDING MATERIALS AND POOR SOILS A MIN. OF 12" DEPTH. BACK FILL WITH GOOD, MEDIUM TEXTURED PLANTING SOILS. ADD A MIN. 2" OF TOPSOIL OVERFILL TO FINISH GRADE. PROVIDE POSITIVE DRAINAGE.
- WATERING OF ALL PLANTS AND TREES TO BE PROVIDED IMMEDIATELY AND MULCHING WITHIN 24 HOURS AFTER INSTALLATION.
- ALL TREE PITS TO BE TESTED FOR PROPER DRAINAGE PRIOR TO TREE PLANTINGS. PROVIDE APPROPRIATE DRAINAGE SYSTEM AS REQUIRED IF THE TREE PIT DOES NOT DRAIN SUFFICIENTLY.
- ALL EXISTING PAVEMENT CONVERTED TO LANDSCAPE/LAWN AREA TO BE EXCAVATED TO A MIN. 16" DEEP. BACK-FILL WITH GOOD CLEAN MEDIUM TEXTURE SOIL 12" DEEP. PROVIDE 4 INCH TOP SOIL TO FINISH GRADE.

landscape plan for:
"Pittsfield Retail"
 City of Ann Arbor, Michigan

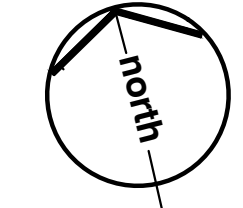
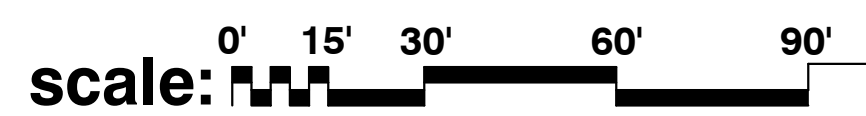

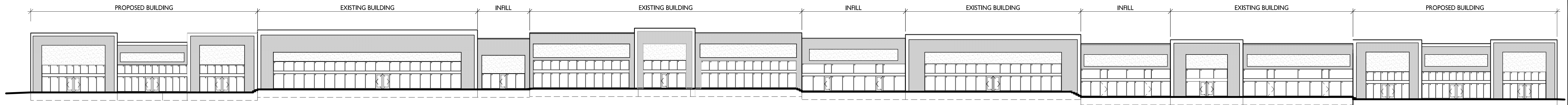

OVERALL NORTH ELEVATION
SCALE: 3/64" = 1'-0"

NOTE: FOR ENGAGED ELEVATIONS SEE A5.01

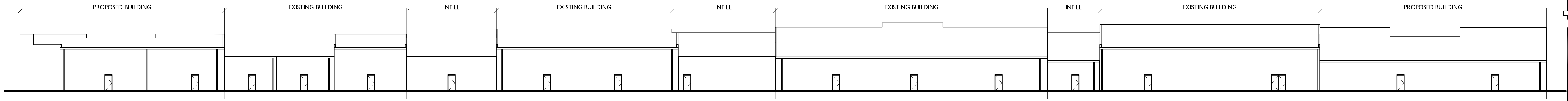

OVERALL SOUTH ELEVATION
SCALE: 3/64" = 1'-0"

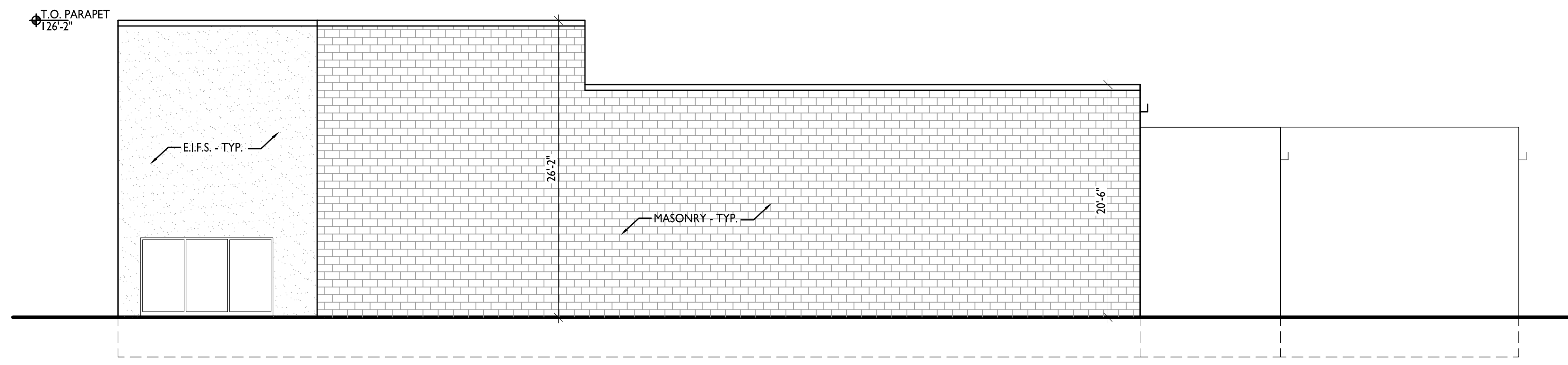

WEST ELEVATION
SCALE: 1/8" = 1'-0"

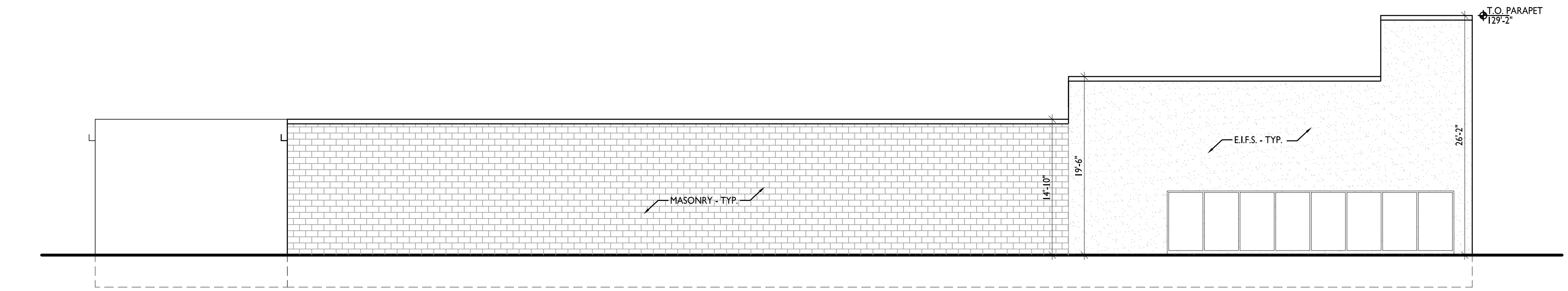

EAST ELEVATION
SCALE: 1/8" = 1'-0"

BOWERS ASSOCIATES
ARCHITECTURE DESIGN
2400 SOUTH HURON PARKWAY • ANN ARBOR, MI 48104
P: 734.975.2400 • F: 734.975.2410
WWW.BOWERSARCH.COM

CONSULTANT + NAME

PROJECT + INFORMATION
WASHTENAW RETAIL
ANN ARBOR, MI

PROJECT + NUMBER
14-311

ISSUE + DATE

SHEET + TITLE
OVERALL ELEVATIONS
14311a500.dwg

SHEET + NUMBER
A5.00

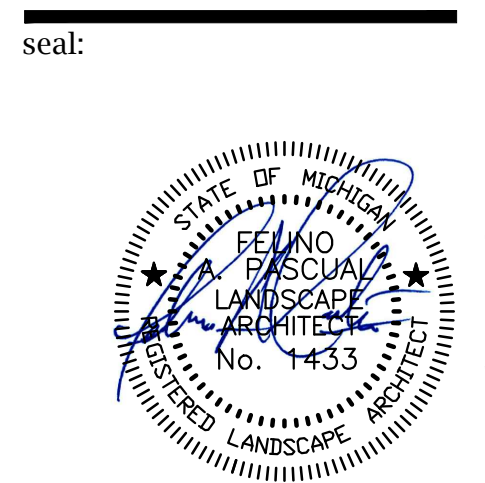

client:
A.F. JONNA
Development and
Management Co.
 4036 Telegraph Road, suite 201
 Bloomfield Hills, Michigan 48302
 ph. (248) 593-6200

project:
PITTSFIELD
RETAIL

project location:
 Washtenaw Ave., Yost
 Blvd. & Pittsfield Blvd.

City of Ann Arbor,
 Michigan

sheet title:
Landscape Plan

job no. / issue / revision date:
 LS14.070.07/SPA/7-27-2014
 LS14.070.09/SPA/9-24-2014
 LS14.070.10/SPA/10-29-2014
 LS14.070.12/SPA/12-7-2014
 LS15.008.01/SPA/2-1-2015

drawn by:
JP, CZ
 checked by:
FP
 date:
1-10-2015
 notice:
 Copyright © 2015
 This document and the subject
 matter contained therein is
 proprietary and is not to be used
 or reproduced without the written
 permission of Felino Pascual and
 Associates
 Do not scale drawings. Use figured
 dimensions only

project no:
LS15.008.01
 sheet no:

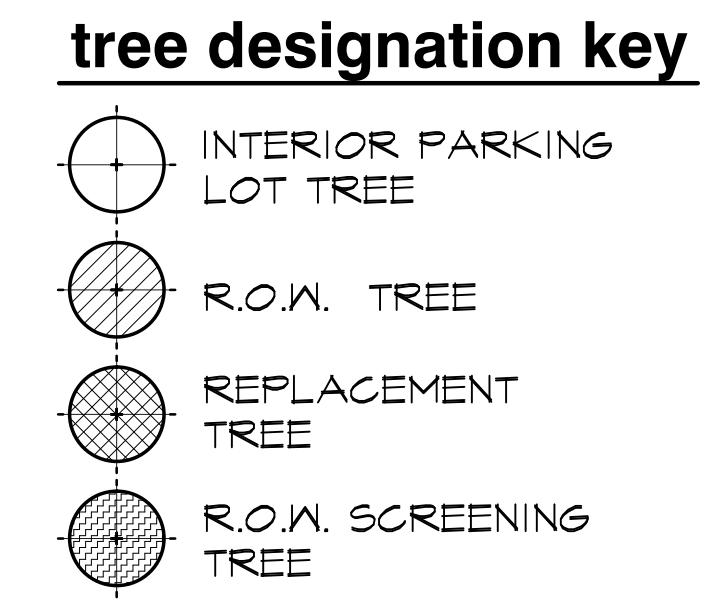
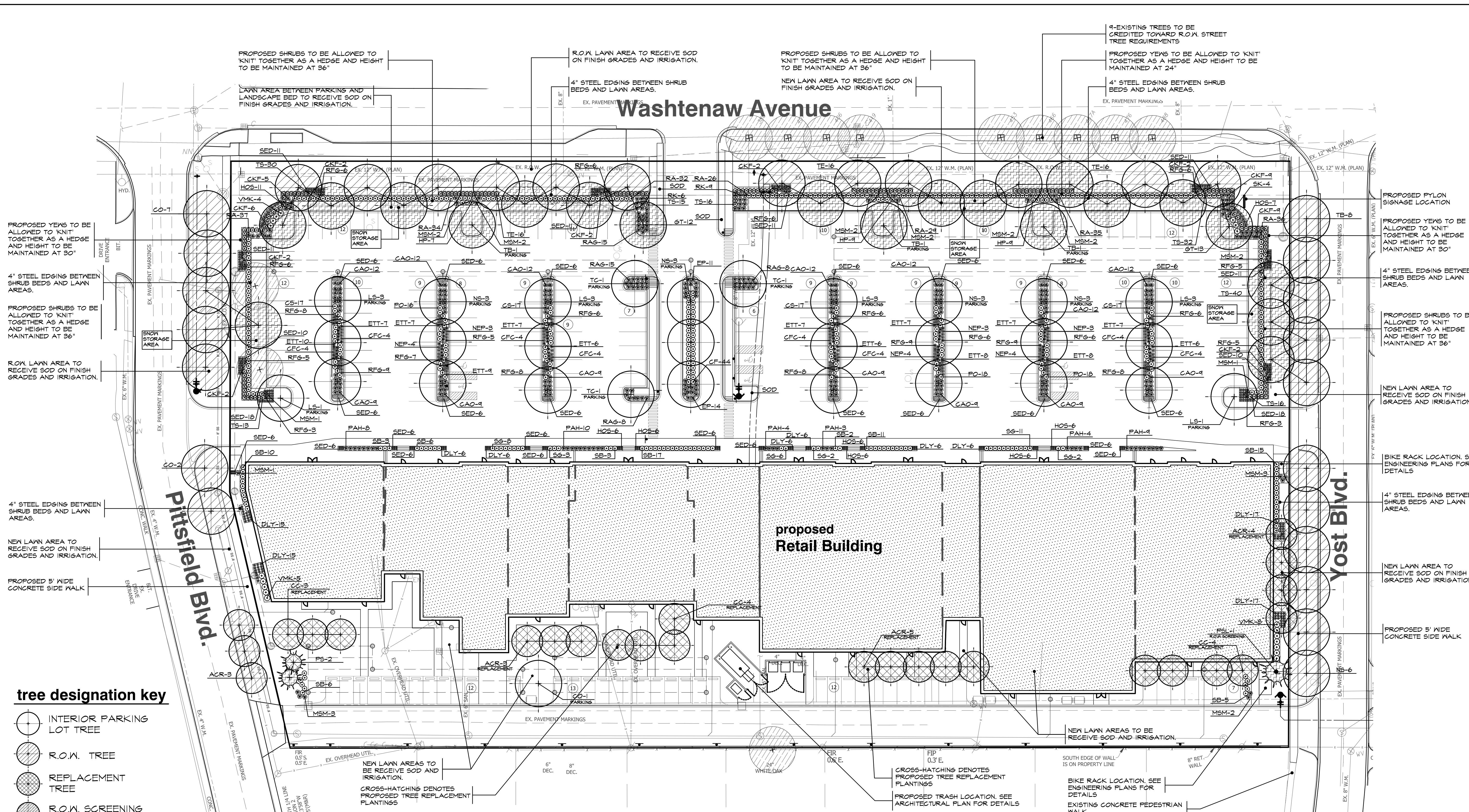

general landscape notes:

1. LANDSCAPE CONTRACTOR SHALL VISIT THE SITE, INSPECT EXISTING CONDITIONS, REVIEW PROPOSED PLANTINGS AND RELATED WORK. CONTACT THE OWNER AND/OR LANDSCAPE ARCHITECT WITH ANY CONCERNS OR DISCREPANCY BETWEEN THE PLAN, PLANT MATERIAL LIST, AND/OR SITE CONDITIONS.
2. PRIOR TO BEGINNING OF CONSTRUCTION ON ANY WORK, CONTRACTORS SHALL VERIFY LOCATIONS OF ALL ON SITE UTILITIES, GAS, ELECTRIC, TELEPHONE, CABLE TO BE LOCATED BY CONTACTING MISS DIG 1-800-482-7171. ANY DAMAGE OR INTERRUPTION OF SERVICES SHALL BE THE RESPONSIBILITY OF THE CONTRACTOR. COORDINATE ALL RELATED WORK ACTIVITIES WITH OTHER TRADES AND REPORT ANY UNACCEPTABLE JOB CONDITIONS TO OWNER PRIOR TO COMMENCING.
3. NUMERICAL VALUE ON THE LANDSCAPE QUANTITIES SPECIFIED ON THE PLAN TAKE PRECEDENCE OVER GRAPHIC REPRESENTATION. VERIFY ANY CONCERN/DISCREPANCY WITH LANDSCAPE ARCHITECT.
4. PLANT MATERIAL LOCATION CANNOT BE CHANGED WITHOUT APPROVAL FROM THE CITY OF ANN ARBOR AND LANDSCAPE ARCHITECT.
5. ALL SUBSTITUTIONS OR DEVIATIONS FROM THE LANDSCAPE PLAN ARE NOT PERMITTED WITHOUT APPROVAL FROM THE CITY OF ANN ARBOR AND LANDSCAPE ARCHITECT.
6. ALL LARGE TREES AND EVERGREENS TO BE STAKED, GUYED AND WRAPPED AS DETAIL SHOWN ON PLAN. STAKING MUST BE REMOVED NO LATER THAN ONE YEAR AFTER PLANTING. TREES SHOULD ONLY BE STAKED IF THEY ARE GREATER THAN 3" CALIPER OR ON A WINDY SITE.
7. PLANT BEDS TO BE DRESSED WITH MIN. 3" OF FINELY DOUBLE SHREDDED HARBARK MULCH.
8. DIG SHRUB PITS 1' LARGER THAN SHRUB ROOT BALLS AND TREE PITS 2' LARGER THAN ROOT BALL. BACK FILL WITH ONE PART TOP SOIL AND ONE PART SOIL FROM EXCAVATED PLANTING HOLE.
9. REMOVE ALL TWINE, WIRE AND BURLAP FROM TREE AND SHRUB EARTH BALLS, AND FROM TREE TRUNKS.
10. NATURAL COLOR, FINELY SHREDDED HARDWOOD BARK MULCH REQUIRED FOR ALL PLANTINGS. 4" THICK BARK MULCH FOR TREES IN 4" DIA. CIRCLE WITH 3" PULLED AWAY FROM TRUNK. 3" THICK BARK MULCH FOR SHRUBS AND 2" THICK BARK MULCH FOR PERENNIALS.
11. PLANT MATERIAL QUALITY & INSTALLATION SHALL BE IN ACCORDANCE WITH THE CURRENT AMERICAN ASSOCIATION OF NURSERYMEN LANDSCAPE STANDARDS.
12. PROVIDE PEAT SOD FOR ALL NEW AND DISTURBED LAWN AREAS UNLESS NOTED OTHERWISE.
13. ALL PLANTING AREAS TO BE PREPARED WITH APPROPRIATE SOIL MIXTURES AND FERTILIZER BEFORE PLANT INSTALLATION.
14. PLANT TREES AND SHRUBS GENERALLY NO CLOSER THEN THE FOLLOWING DISTANCES FROM SIDEWALKS, CURBS AND PARKING STALLS:
 - a). SHADE TREES _____ 5 FT.
 - b). ORNAMENTAL AND EVERGREEN TREES (CRAB, PINE, SPRUCE, ETC.) _____ 10 FT.
 - c). SHRUBS THAT ARE LESS THAN 1 FOOT TALL AND WIDE AT MATURITY. _____ 2 FT.
15. NO TREES OR EVERGREENS TO BE INSTALLED OVER ANY PROPOSED OR EXISTING UTILITY LINES AS SHOWN ON THE OVERALL LANDSCAPE PLAN. SEE ENGINEERING PLANS FOR EXACT LOCATION AND DETAILS.
16. ALL LAWN AREAS AND LANDSCAPE BEDS TO BE FULLY IRRIGATED WITH A AUTOMATIC UNDERGROUND SYSTEMS. IRRIGATION SYSTEM TO HAVE SEPARATE ZONES FOR LAWN AREAS, PARKING ISLANDS, AND SHRUB BEDS WITH DIFFERENT CONTROL. MOISTURE LEVEL ADJUSTMENT PER ZONE AS REQUIRED. IRRIGATION PLAN TO BE PROVIDED AT LATER DATE.
17. UNLESS NOTED OTHERWISE, LANDSCAPE BEDS ADJACENT TO LAWN TO RECEIVE EDGING. EDGING SHALL BE 4" X 1/8" METAL (FINISH BLACK OR GREEN) OR APPROVED EQUAL AND TO BE INSTALLED WITH HORIZONTAL METAL STAKES AT 32" O.C. OR PER MANUFACTURER'S SPECIFICATION.
18. ALL LANDSCAPE BEDS ADJACENT AND NEXT TO BUILDING SHALL BE EXCAVATED OF ALL BUILDING MATERIALS AND POOR SOILS A MIN. OF 12" DEPTH. BACK FILL WITH GOOD, MEDIUM TEXTURED PLANTING SOILS. ADD A MIN. 2" OF TOPSOIL OVERFILL TO FINISH GRADE. PROVIDE POSITIVE DRAINAGE.
19. WATERING OF ALL PLANTS AND TREES TO BE PROVIDED IMMEDIATELY AND MULCHING WITHIN 24 HOURS AFTER INSTALLATION.
20. ALL TREE PITS TO BE TESTED FOR PROPER DRAINAGE PRIOR TO TREE PLANTING. PROVIDE APPROPRIATE DRAINAGE SYSTEM AS REQUIRED IF THE TREE PIT DOES NOT DRAIN SUFFICIENTLY.
21. ALL EXISTING PAVEMENT CONVERTED TO LANDSCAPE/LAWN AREA TO BE EXCAVATED TO A MIN. 16" DEEP. BACK-FILL WITH GOOD CLEAN MEDIUM TEXTURE SOIL 12" DEEP. PROVIDE 4 INCH TOP SOIL TO FINISH GRADE.

A FORESTRY PERMIT TO BE OBTAINED TO THE CITY OF ANN ARBOR PRIOR TO ANY REMOVAL OR PLANTING OF STREET TREES (IN R.O.W. AREA). A SEPARATE PERMIT WILL BE OBTAINED FOR EACH ACTIVITY.

landscape plan for:
"Pittsfield Retail"
 City of Ann Arbor, Michigan

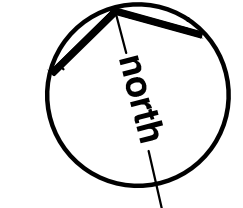
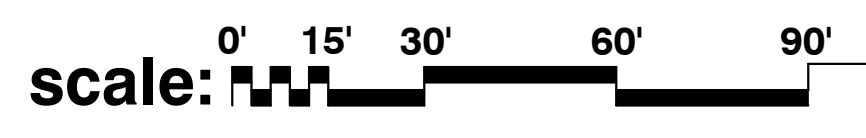

PITTSFIELD RETAIL DEVELOPMENT AGREEMENT

THIS AGREEMENT, made this leave blank day of leave blank, 20 , by and between the City of Ann Arbor, a Michigan Municipal Corporation, with principal address at 301 East Huron Street, Ann Arbor, Michigan 48107, hereinafter called the CITY; and fill in name of Proprietor, a fill in name of entity, with principal address at 4036 Telegraph Road, Suite 201, Bloomfield Hills, Michigan 48302, hereinafter called the PROPRIETOR, witnesses that:

WHEREAS, the PROPRIETOR owns certain land in the City of Ann Arbor, described below and site planned as Pittsfield Retail, and

WHEREAS, the PROPRIETOR has caused certain land in the City of Ann Arbor, described below to be surveyed, mapped and site planned as Pittsfield Retail, and desires site plan approval and development agreement approval thereof, and

WHEREAS, the PROPRIETOR desires to build or use certain improvements with and without the necessity of special assessments by the CITY, and

WHEREAS, the CITY desires to insure that all of the improvements required by pertinent CITY ordinances and regulations be properly made, and that the PROPRIETOR will install these improvements prior to any permits being issued.

THE PROPRIETOR(S) HEREBY AGREE(S):

(P-1) To prepare and submit to the CITY for approval plans and specifications ("the Plans") prepared by a registered professional engineer for construction of public water and sanitary sewer mains, public and private storm water management systems, and sidewalks. ("the Improvements") provided that no work on said Improvements shall be commenced until the Plans have been approved by the City Administrator or designee, and until such other relevant information to CITY service areas as shall be reasonably required has been provided.

(P-2) To construct all improvements set forth in Paragraph P-1 of this Agreement in accordance with the approved Plans and to repair all defects in the improvements that occur within one year from the date of acceptance of the Improvements by the CITY, commencing on the latest date of the acceptance of any Improvements by the CITY. If the PROPRIETOR fails to construct the improvements, the CITY may send notice via first class mail to the PROPRIETOR at the address listed above requiring it to commence and complete the improvements in the notice within the time set forth in the notice. The CITY may cause the work to be completed at the expense of the PROPRIETOR, if the PROPRIETOR does not complete the work within the time set forth in the notice. Every owner of a portion of the property, including co-owners of condominium units, shall pay a pro-rata share of the cost of the work. That portion of the cost of the work attributable to each condominium unit shall be a lien on that Property and may be collected as a single tax parcel assessment as provided in Chapter 13 of the Ann Arbor City Code.

(P-3) To furnish, within 30 days of completion, an engineer's certificate that the construction of the public improvements set forth in Paragraph P-1 above have been completed in accordance with the specifications of the CITY in accordance with the approved plans. The engineer's certificate will cover only those items the PROPRIETOR'S engineer inspects.

(P-4) To grant easements to the CITY for utilities as shown on the approved site plan and the final approved construction plan, subject to City Council approval. PROPRIETOR shall submit legal description and survey drawing for the easements prior to the request for and issuance of building permits and the easements shall be granted to the CITY in a form acceptable to the CITY Attorney. The easements must be accepted prior to the request for and issuance of any temporary or final certificate of occupancy.

(P-5) To install all required utilities, pursuant to CITY approved plans and specifications, necessary to connect the site with existing CITY systems adjacent to the site prior to the issuance of any building permits.

(P-6) To be included in a future special assessment district, along with other benefiting property, for the construction of additional improvements to Washtenaw Avenue, such as street widening, storm sewers, curb and gutter, sidewalks, bike paths, street lights, and the planting of trees along Washtenaw Avenue, frontage when such improvements are determined by the CITY to be necessary.

(P-8) To indemnify and hold the CITY harmless from any claims, losses, liabilities, damages or expenses (including reasonable attorney fees) suffered or incurred by the CITY based upon or resulting from any acts or omissions of the PROPRIETOR, its employees, agents, subcontractors, invitees, or licensees in the design, construction, maintenance or repair of any of the Improvements required under this Agreement and the approved site plan.

(P-9) To cause to be maintained General Liability Insurance and Property Damage Insurance in the minimum amount of \$1,000,000 per occurrence and naming the CITY as named insured to protect and indemnify the CITY against any claims for damage due to public use of the public improvement(s) in the development prior to final written acceptance of the public improvement(s) by the CITY. Evidence of such insurance shall be produced prior to any construction of improvement and a copy filed with the City Clerk's Office and shall remain in full force and effect during construction of the public improvement(s) and until notice of acceptance by the CITY of the Improvements.

(P-10) Existing landmark and street trees shown on the site plan as trees to be saved shall be maintained by the PROPRIETOR in good condition for a minimum of three years after acceptance of the public improvements by the CITY or granting of Certificate of Occupancy. Existing landmark and street trees that are determined by the CITY to be dead, dying or severely damaged due to construction activity within three years after acceptance of the public improvements or granting of Certificate of Occupancy, shall be replaced by the PROPRIETOR as provided by Chapter 57 of the Ann Arbor City Code.

(P-11) To deposit, prior to any building permits being issued, a street tree planting escrow account with the Parks and Recreation Services Unit in the form of a check payable to the City of Ann Arbor. The escrow amount shall be based on the CITY policy in effect at that time and is to include all on-site public streets. The City Administrator may authorize the PROPRIETOR to install the street trees if planted in accordance with CITY standards and

specifications. If the street trees are found to be acceptable by the CITY, the escrow amount will be returned to the PROPRIETOR one year after the date of acceptance by the CITY.

(P-12) To construct, repair and/or adequately maintain on-site storm water management system. If the PROPRIETOR fails to construct, repair and/or maintain the private storm water management system, the CITY may send notice via first class mail to the PROPRIETOR at the address listed above, requiring it to commence and complete the items stated in the notice within the time set forth in the notice. The CITY may cause the work to be completed at the expense of the PROPRIETOR if the PROPRIETOR does not complete the work within the time set forth in the notice.

(P-13) After construction of the private on-site storm water management system, to commission an annual inspection of the system by a registered professional engineer evaluating its operation and stating required maintenance or repairs, and to provide a written copy of this evaluation to the CITY Public Services Area.

(P-14) To design, construct, repair and maintain this development in accordance with the provisions of Chapter 119 (Noise Control) to ensure that any noise emanating from said development will not impact nearby residents or businesses. In addition, PROPRIETOR shall review existing noise sources surrounding said development and incorporate necessary design and construction techniques to ensure that future tenants will not be exposed to noise sources in violation of Chapter 119.

(P-15) To remove all discarded building materials and rubbish from the development at least once each month during construction of the development improvements, and within one month after completion or abandonment of construction.

(P-16) Prior to application for and issuance of certificates of occupancy, to disconnect one footing drain, which is based upon the uses currently existing on the Property and those currently contemplated by the Site Plan in accordance with the Guidelines for Completion of Footing Drain Disconnections, Table A, and adopted by City Council, August 18, 2003 and revised November 30, 2005 (the "Guidelines"), or to provide an alternative method of mitigation that results in an equivalent amount of sanitary flow removal, in accordance with the Guidelines. In the event the actual intensity of uses contemplated by the Site Plan are either increased or decreased, City and PROPRIETOR agree to adjust the number of footing drains to be disconnected, or the amount of alternative mitigation to be provided, in accordance with the Guidelines. PROPRIETOR may be allowed to obtain partial certificates of occupancy for the development prior to the completion of all of the required footing drain disconnects on a prorated basis at the Discretion of the CITY Public Services Area.

(P-17) PROPRIETOR is the sole title holder in fee simple of the land described below except for any mortgage, easements and deed restrictions of record and that the person(s) signing below on behalf of PROPRIETOR has (have) legal authority and capacity to enter into this agreement for PROPRIETOR.

(P-18) Failure to construct, repair and/or maintain the site pursuant to the approved site plan and/or failure to comply with any of this approved development agreement's terms and conditions shall constitute a material breach of the Agreement and the CITY shall have all remedies in law and/or in equity necessary to ensure that the PROPRIETOR complies with the approved site plan and/or the terms and conditions of the approved development agreement. The PROPRIETOR shall be responsible for all costs and expenses including reasonable

attorney fees incurred by the CITY in enforcing the terms and conditions of the approved site plan and/or development agreement.

(P-19) In addition to any other remedy set forth in this Agreement or in law or equity, if PROPRIETOR fails to make a timely or full payments to the CITY as set forth elsewhere in the Agreement to the CITY in the agreed upon manner, any unpaid amount(s) shall become a lien, as provided under Ann Arbor City Code and recorded with the Washtenaw County Register of Deeds, against the land described below and may be placed on the CITY tax roll as a single lot assessment, or if the development is converted to condominium ownership, every owner of a portion of the property shall pay a pro-rata share of the amount of the payments attributable to each condominium unit. If the unpaid amount(s), in whole or in part, has been recorded as a lien on the CITY'S tax roll and with the Washtenaw County Register of Deeds, upon payment of the amount in full along with any penalties and interest, the CITY, upon request, will execute an instrument in recordable form acknowledging full satisfaction of this condition.

(P-20) To pay for the cost of recording this Agreement with the Washtenaw County Register of Deeds, and to pay for the cost of recording all documents granting easements to the CITY.

THE CITY HEREBY AGREES:

(C-1) In consideration of the above undertakings, to approve the Pittsfield Retail Site Plan.

(C-2) To provide timely and reasonable CITY inspections as may be required during construction.

(C-3) To record this agreement with the Washtenaw County Register of Deeds.

GENERAL TERMS

Both the PROPRIETOR and the CITY agree as follows:

(T-1) This agreement is not intended to create a contractual right for third parties.

(T-2) This Agreement and any of its terms, conditions, or provisions cannot be modified, amended, or waived unless in writing and unless executed by both parties to this Agreement. Any representations or statements, whether oral or in writing, not contained in this Agreement shall not be binding on either party.

(T-3) This Agreement and any of its terms or conditions shall not be assigned or transferred to any other individual or entity unless prior approval of the CITY is received. Such approval shall not be withheld unreasonably.

(T-4) The obligations and conditions on the PROPRIETOR, as set forth above in this Agreement and in the approved site plan, shall be binding on any successors and assigns in ownership of the following described parcel:

legal description(s) to be inserted here

(T-5) In addition to any other remedy in law or in equity failure to comply with all of the above paragraphs on the part of the PROPRIETOR, or any part of the approved site plan, in part or in whole, shall give the CITY adequate basis and cause to issue a stop work order for any previously-issued building permits and shall be an adequate basis and cause for the CITY to deny the issuance of any building permits, certificates of occupancy, or any other permits unless and until the CITY has notified the PROPRIETOR in writing that the PROPRIETOR has satisfactorily corrected the item(s) the PROPRIETOR has failed to perform.

(T-6) This agreement shall be interpreted, enforced and governed under the laws of the State of Michigan and Ann Arbor City Code.

IN WITNESS WHEREOF, the parties hereto have set their hands and seals the day first above written.

Witnesses:

CITY OF ANN ARBOR, MICHIGAN
301 East Huron Street
Ann Arbor, Michigan 48107

By: _____
Christopher Taylor, Mayor

By: _____
Jacqueline Beaudry, City Clerk

Approved as to Substance:

Steven D. Powers, City Administrator

Approved as to Form:

Stephen K. Postema, City Attorney

Witness:

By: _____
Jordan Jenna, Manager

STATE OF MICHIGAN)
) ss:
County of Washtenaw)

On this _____ day of _____, 20___, before me personally appeared John Hieftje, Mayor, and Jacqueline Beaudry, Clerk of the City of Ann Arbor, a Michigan Municipal Corporation, to me known to be the persons who executed this foregoing instrument, and to me known to be such Mayor and Clerk of said Corporation, and acknowledged that they executed the foregoing instrument as such officers as the free act and deed of said Corporation by its authority.

NOTARY PUBLIC
County of Washtenaw, State of Michigan
My Commission Expires: _____
Acting in the County of Washtenaw

STATE OF MICHIGAN)
) ss:
County of Washtenaw)

On this _____ day of _____, 20___, before me personally appeared _____, to me known to be the person who executed the foregoing instrument, and acknowledged that he executed the foregoing instrument as his free act and deed.

NOTARY PUBLIC
County of Washtenaw, State of Michigan
My Commission Expires: _____
Acting in the County of Washtenaw

DRAFTED BY AND AFTER RECORDING RETURN TO:
Ann Arbor Planning & Development Services
Post Office Box 8647
Ann Arbor, Michigan 48107
(734) 794-6265