

ANN ARBOR HISTORIC DISTRICT COMMISSION

Staff Report

ADDRESS: 315 Second Street, Application Number HDC13-038

DISTRICT: Old West Side Historic District

REPORT DATE: April 5, 2013

REPORT PREPARED BY: Jill Thacher, Historic Preservation Coordinator

REVIEW COMMITTEE DATE: Monday, April 8 for the Thursday, April 11, 2012 HDC meeting

OWNER	APPLICANT
Name: John Rogers	Same
Address: 315 Second Street #215 Ann Arbor, MI 48103	
Phone: (734) 657-2385	

BACKGROUND: This block (Liberty/Second/William/First) had a mix of industrial and residential uses from at least 1880, when a tannery and several houses were located here. In 1925 there were five houses, a lodge/club room, and an auto parts manufacturer that covered less than one-eighth of the block. By 1931 the King-Seeley Corporation (manufacturers at that time of liquid depth gauges) had nearly doubled the size of the plant and removed the lodge, though the houses remained. By 1966 the block looked similar to the way it did when the Liberty Lofts project was approved in 2004-5, with a very large manufacturing building, the service station, and the houses at 307 and 311 Second.

LOCATION: The site occupies most of the block bounded by West Liberty Street, Second Street, West William Street, and South First Street. This unit is on the southwest corner of the building (facing West William and the parking lot) on the second floor.

APPLICATION: The applicant seeks HDC approval to install two 18' wide retractable canvas awnings over a large roof deck.

APPLICABLE REGULATIONS:

From the Secretary of the Interior's Standards for Rehabilitation:

- (9) New additions, exterior alterations, or related new construction shall not destroy historic materials that characterize the property. The new work shall be differentiated from the old and shall be compatible with the massing, size, scale, and architectural features to protect the historic integrity of the property and its environment.

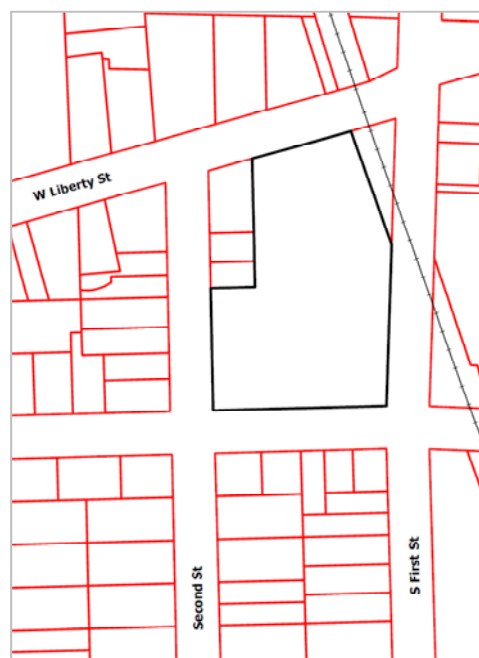

From the Ann Arbor Historic District Design Guidelines for Residential Awnings:

Appropriate: Installing the frame so historic trim and character-defining features are not destroyed or obscured.

Using canvas, vinyl-coated canvas, or acrylic fabrics.

Using an awning that is compatible in scale and form to the historic structure.

STAFF FINDINGS:

1. The applicant proposes installing two new fabric awnings on the west-facing wall of their condominium. The unit is on the second floor, and its western wall opens onto a large roof deck on top of the one-story main entrance section of the building. The awnings would shade the bedroom and living room from direct sun in summer. Each would be 18 feet wide, matching the width of the window sections. The awnings would be retractable and, per the applicant, non-motorized. The color has not been selected yet.
2. The wall that the awnings would be attached to are concrete with a stucco finish. Each awning would require six brackets, per the supplied specs.
3. The proposed awnings are large, but since they are located on a very large roof deck and are not designed to be left open like a fixed-frame awning, staff feels they are compatible with the historic building. They do not obscure or destroy any character-defining features of the building, are removable, and serve a traditional role in climate control for the condominium unit.

POSSIBLE MOTIONS: (Note that the motion is only a suggestion. The Review Committee, consisting of staff and at least two Commissioners, will meet with the applicant on site and then make a recommendation at the meeting.)

I move that the Commission issue a certificate of appropriateness for the application at 315 South Second Street, a contributing property in the Old West Side Historic District, to install two new retractable awnings. The proposed work is compatible in exterior design, arrangement, material and relationship to the rest of the building and the surrounding area and meets *The Secretary of the Interior's Standards for Rehabilitation*, in particular standard 9, and the *Ann Arbor Historic District Design Guidelines* for residential awnings.

MOTION WORKSHEET:

I move that the Commission issue a Certificate of Appropriateness for the work at 315 Second Street in the Old West Side Historic District

_____ Provided the following condition(S) is (ARE) met: 1) STATE CONDITION(s)

The work is generally compatible with the size, scale, massing, and materials and meets the Secretary of the Interior's Standards for Rehabilitation, standard(S) number(S) (*circle all that apply*): 1, 2, 3, 4, 5, 6, 7, 8, 9, 10

ATTACHMENTS: application, manufacturer's information, photos.

315 Second, (March 2008, unit 215 indicated)





City of Ann Arbor
PLANNING & DEVELOPMENT SERVICES — PLANNING SERVICES

100 North Fifth Avenue | P.O. Box 8647 | Ann Arbor, Michigan 48107-8647
p. 734.794.6265 | f. 734.994.8312 | planning@a2gov.org

ANN ARBOR HISTORIC DISTRICT COMMISSION APPLICATION

Section 1: Property Being Reviewed and Ownership Information

Address of Property: 315 Second St. # 215, 48103

Historic District: Old West Side

Name of Property Owner (If different than the applicant):

Address of Property Owner: _____

Daytime Phone and E-mail of Property Owner: 734-657-2385, jmraa@aol.com

Signature of Property Owner: J. Rogers Date: 4-1-13

Section 2: Applicant Information

Name of Applicant: John M. Rogers

Address of Applicant: 315 Second St. # 215 48103

Daytime Phone: (734) 657-2385 Fax: () _____

E-mail: jmraa@aol.com

Applicant's Relationship to Property: owner architect contractor other

Signature of applicant: J. Rogers Date: 4-1-13

Section 3: Building Use (check all that apply)

Residential Single Family Multiple Family Rental

Commercial Institutional

Section 4: Stille-DeRossett-Hale Single State Construction Code Act

(This item **MUST BE INITIALED** for your application to be **PROCESSED**)

Public Act 169, Michigan's Local Historic Districts Act, was amended April 2004 to include the following language: "...the applicant has certified in the application that the property where the work will be undertaken has, or will have before the proposed completion date, a fire alarm or smoke alarm complying with the requirements of the Stille-DeRossett-Hale Single State Construction Code Act, 1972 PA 230, MCL 125.1501 to 125.1531."

Please initial here: 

Section 5: Description of Proposed Changes (attach additional sheets as necessary)

1. Provide a brief summary of proposed changes. _____

INSTALL two awnings FOR OUR DECK
ONE TO shade bedroom
ONE to shade livingroom
Both are retractable.

2. Provide a description of existing conditions. NO Awnings THERE NOW.

3. What are the reasons for the proposed changes? OUR WINDOWS, WHICH ARE VIRTUALLY THE WALLS IN OUR CONDO (SEE PICTURES) FACE WEST. SUN IS BRUTAL DURING SUMMER.

4. Attach any additional information that will further explain or clarify the proposal, and indicate these attachments here.

There is picture of Sun Setter Awnings. Awning depicted is 18 ft. we will buy two of these from Sun Setter, may be different color

5. Attach photographs of the existing property, including at least one general photo and detailed photos of proposed work area.

STAFF USE ONLY

Date Submitted: _____ Application to _____ Staff or _____ HDC

Project No.: HDC Fee Paid: 100⁰⁰

Pre-filing Staff Reviewer & Date: _____ Date of Public Hearing: _____

Application Filing Date: _____ Action: _____ HDC COA _____ HDC Denial

Staff signature: _____ _____ HDC NTP _____ Staff COA

Comments:

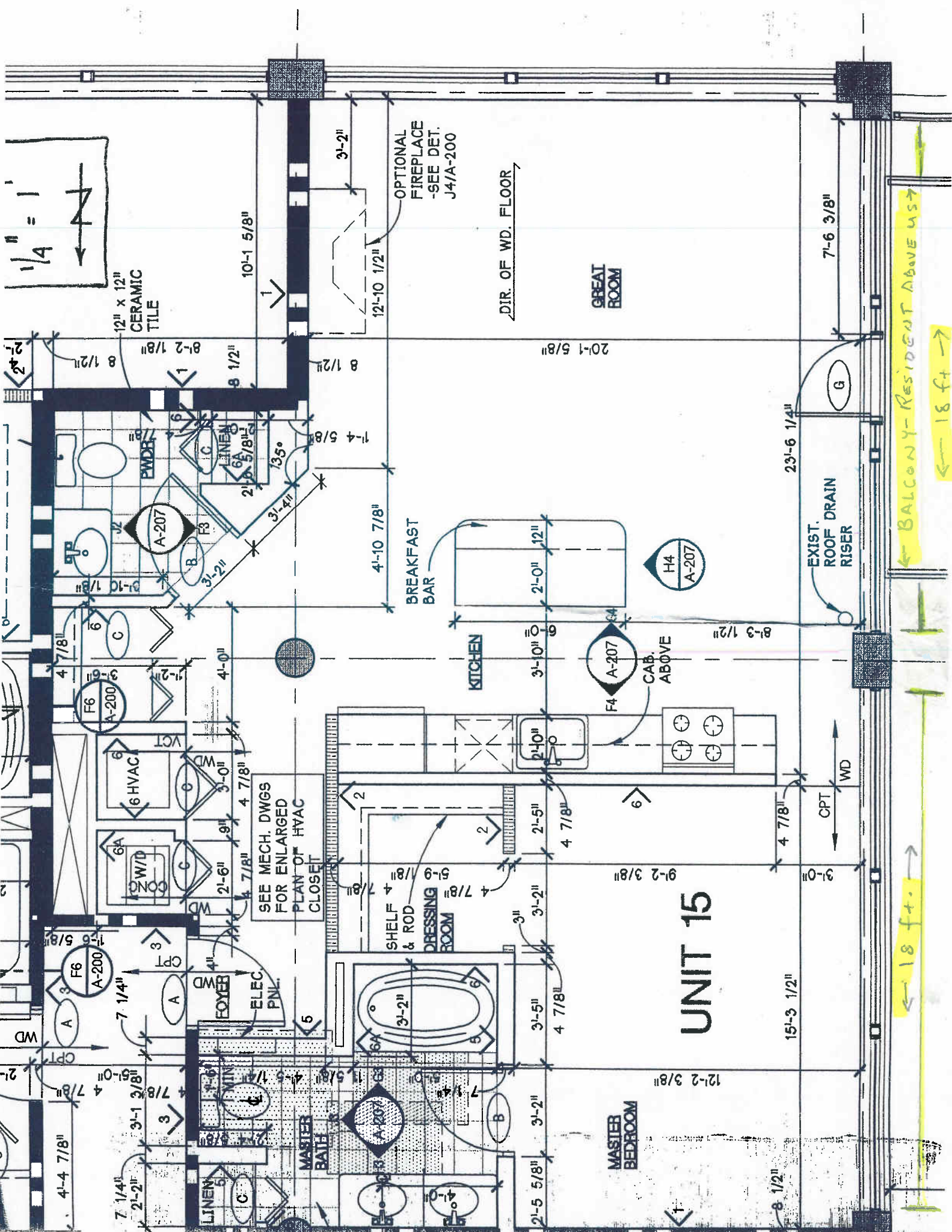

12" x 12" CERAMIC TILE

OPTIONAL FIREPLACE -SEE DET. J4/A-200

DIR. OF WD. FLOOR

GREAT ROOM

7'-6 3/8"

EXIST. ROOF DRAIN RISER

BALCONY-RESIDENT ABOVE US

← 18 ft →

← 18 ft →

SEE MECH. DWGS FOR ENLARGED PLAN OF HVAC CLOSET

UNIT 15

MASTER BEDROOM

DRESSING ROOM

KITCHEN

BREAKFAST BAR

LINEIN

W.C.

FOYER

ELEC. PNL.

CLINET

DRESSING ROOM

MASTER BATH

LINEIN

W.C.

FOYER

ELEC. PNL.

CLINET

DRESSING ROOM

MASTER BATH

LINEIN

W.C.

FOYER

ELEC. PNL.

CLINET

DRESSING ROOM

MASTER BATH

LINEIN

W.C.

FOYER

ELEC. PNL.

CLINET

DRESSING ROOM

MASTER BATH

LINEIN

W.C.

FOYER

ELEC. PNL.

CLINET

DRESSING ROOM

MASTER BATH

LINEIN

W.C.

FOYER

ELEC. PNL.

CLINET

DRESSING ROOM

MASTER BATH

LINEIN

W.C.

FOYER

ELEC. PNL.

CLINET

DRESSING ROOM

MASTER BATH

LINEIN

W.C.

FOYER

ELEC. PNL.

CLINET

DRESSING ROOM

MASTER BATH

LINEIN

W.C.

FOYER

ELEC. PNL.

Awning Installation Instructions

WARNING: FAILURE TO FOLLOW THESE INSTRUCTIONS COULD RESULT IN PERSONAL INJURY!

WARNING: DO NOT REMOVE THE PLASTIC SAFETY SLEEVES FROM THE LATERAL ARMS UNTIL INSTRUCTED TO DO SO.

WARNING: NEVER ATTEMPT TO REPAIR OR DISSASSEMBLE ANY PART OF THE AWNING WITHOUT FOLLOWING REPLACEMENT PART PROCEDURES SUPPLIED BY THE MANUFACTURER. TRYING TO DO SO WITHOUT PROPER INSTRUCTIONS COULD RESULT IN PERSONAL INJURY!

Before Starting

1. Before beginning, please familiarize yourself with the components of the awning as shown in Figure 1, and the supplied fasteners/parts shown on pages 6 & 7. Find the mounting brackets (wall or soffit) in the package (they are separated from the awning itself). **If you are mounting the awning on a soffit, please go to Appendix C on page 18 for this type of installation.**

Note: This figure shows awning with motor installed on the right side as you face the house.

Note: Number of brackets supplied with the awning will vary depending on awning size, see page 6.

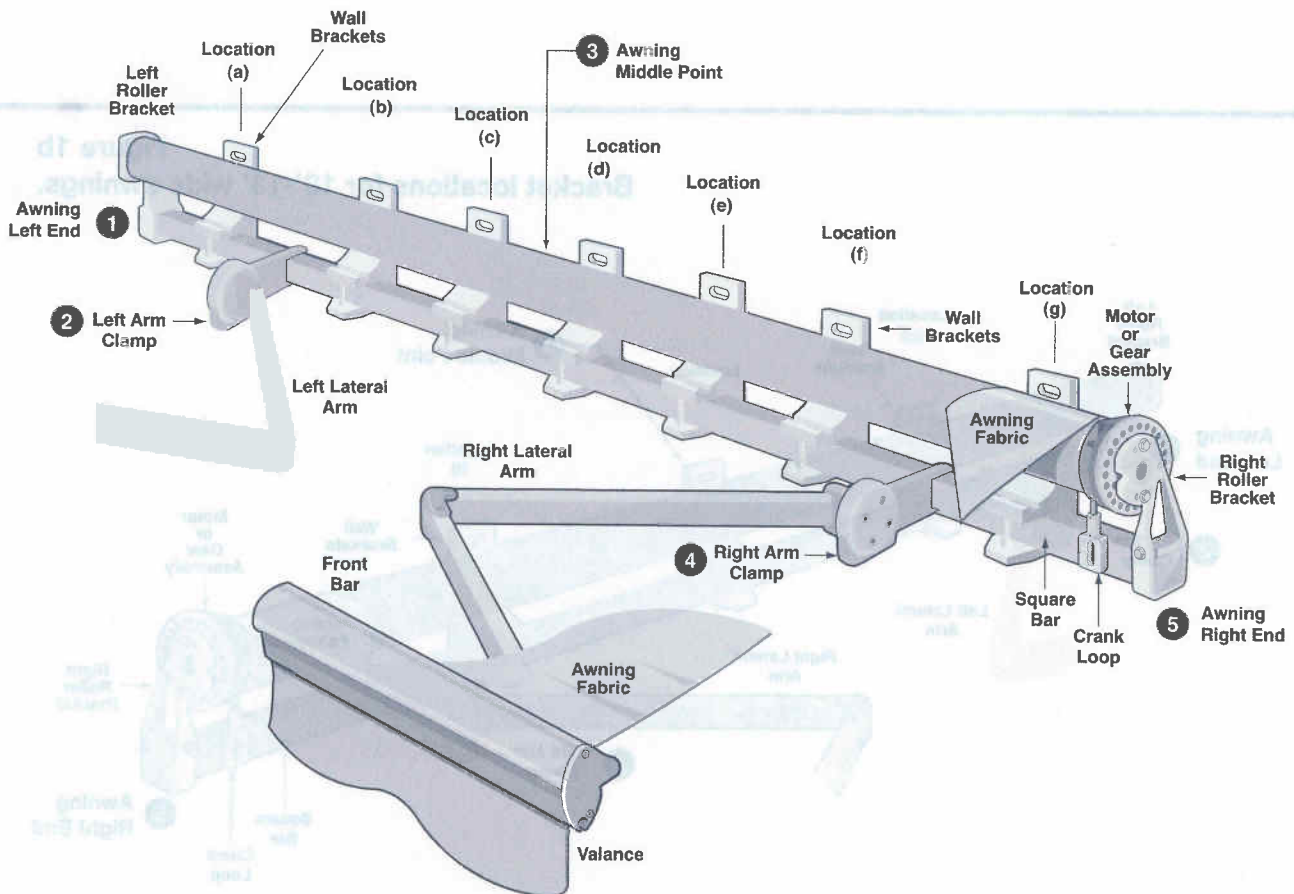

Figure 1

Figure 1a
Bracket locations for 8' wide awnings.

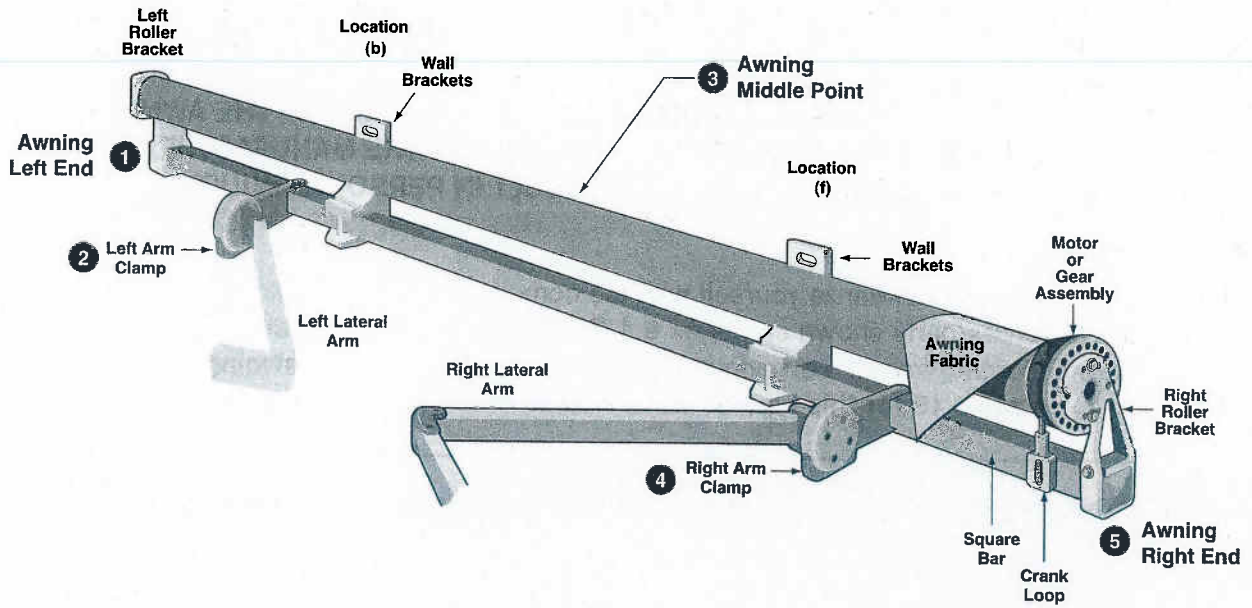

Figure 1b
Bracket locations for 10'-13' wide awnings.

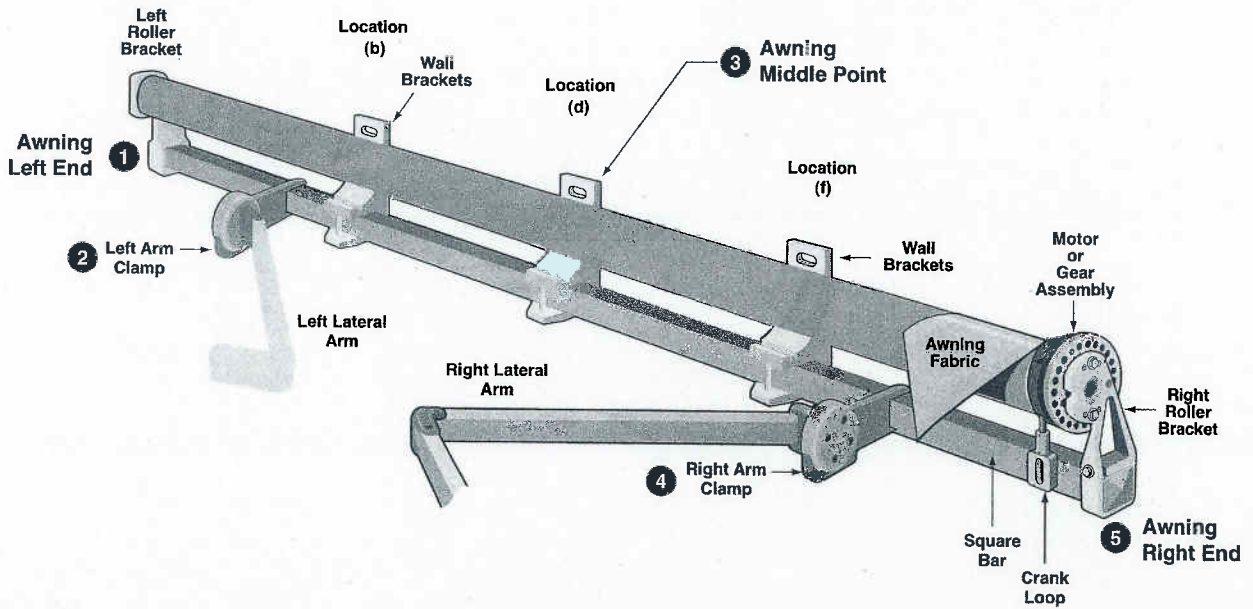

Figure 1c
Bracket locations for 14'-16' wide awnings.

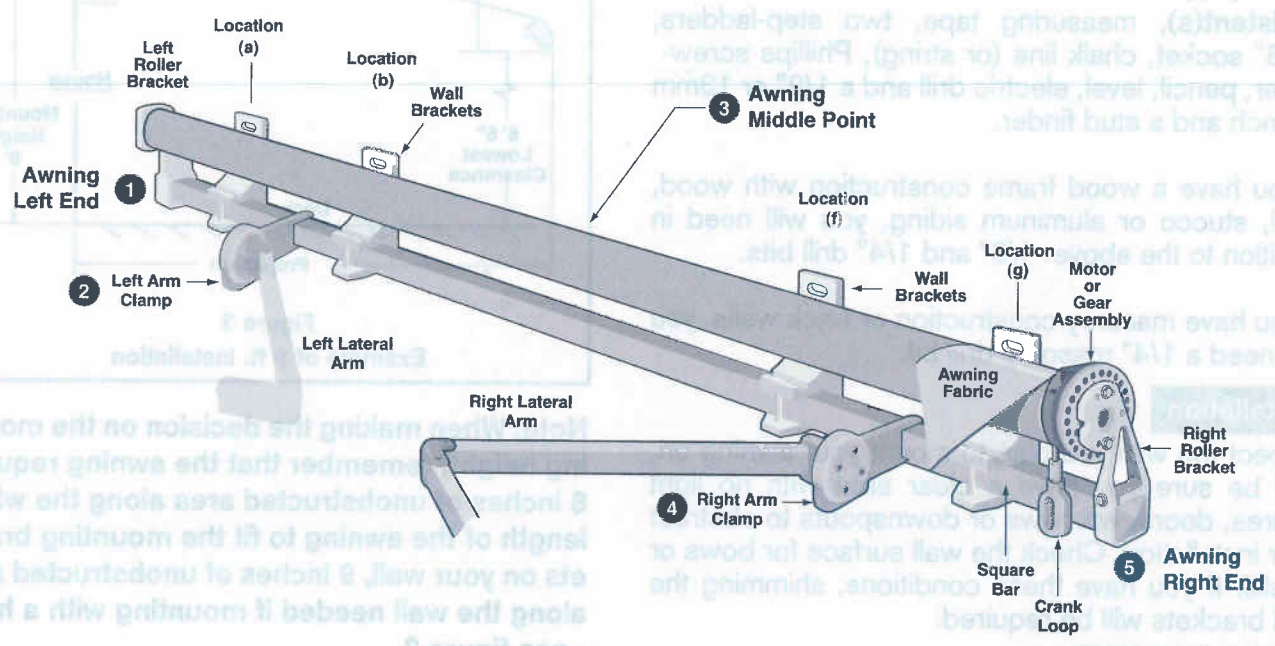
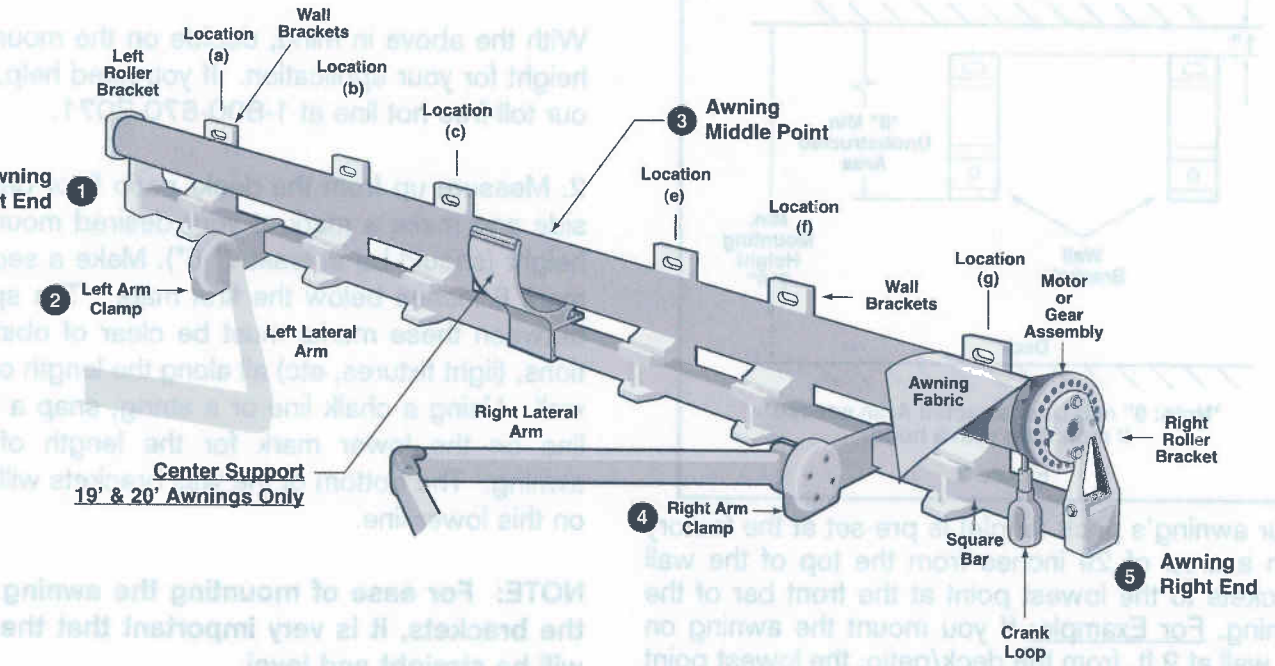

Figure 1d
Bracket locations for 17'-20' wide awnings.



Tools Required

In your package you will find the following tools: 6mm Allen wrench.

For any type of wall construction you will need an assistant(s), measuring tape, two step-ladders, 9/16" socket, chalk line (or string), Phillips screwdriver, pencil, level, electric drill and a 1/2" or 13mm wrench and a stud finder.

If you have a wood frame construction with wood, vinyl, stucco or aluminum siding, you will need in addition to the above: 1/8" and 1/4" drill bits.

If you have masonry construction or brick walls, you will need a 1/4" masonry drill bit.

Installation

Inspect the wall you plan to mount your awning on, and be sure you have a clear area with no light fixtures, doors, windows or downspouts to obstruct your installation. Check the wall surface for bows or swells. If you have these conditions, shimming the wall brackets will be required.

Mounting Height

The mounting height is defined as one inch above the highest part of the wall bracket from the deck/patio floor - see figure 2.

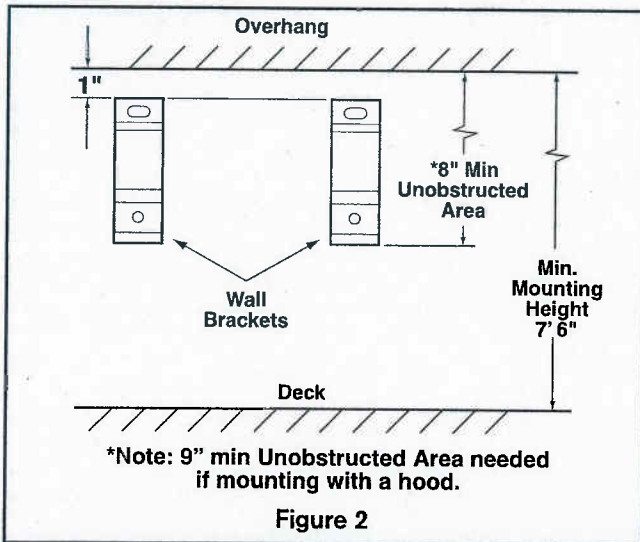

Your awning's pitch (angle) is pre-set at the factory with a drop of 29 inches from the top of the wall brackets to the lowest point at the front bar of the awning. For Example: If you mount the awning on the wall at 9 ft. from the deck/patio, the lowest point at the front bar of the awning at full projection will be 6 foot 6 inches - see figure 3. The awning pitch (angle) can be adjusted after installing the awning.

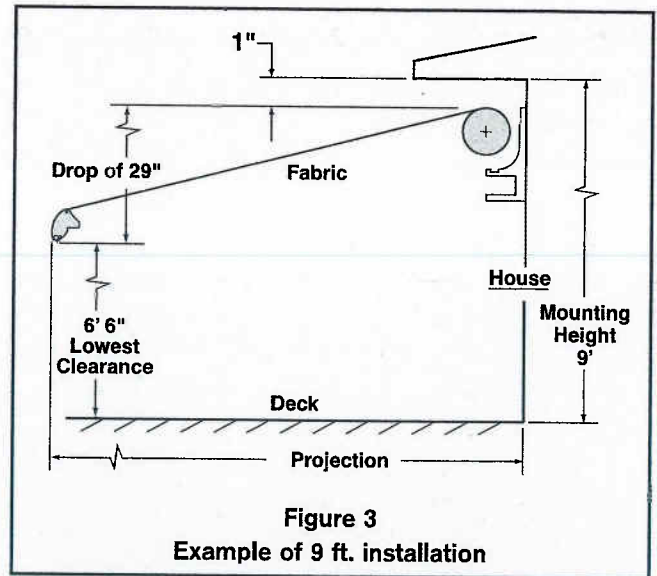

Note: When making the decision on the mounting height, remember that the awning requires 8 inches of unobstructed area along the whole length of the awning to fit the mounting brackets on your wall, 9 inches of unobstructed area along the wall needed if mounting with a hood - see figure 2.

To assure head clearance at the front of the awning, we recommend to install the awning above 7 foot 6 inches from the deck/ patio, with an optimal mounting height of 9 foot or above.

With the above in mind, decide on the mounting height for your application. If you need help, call our toll-free hot line at 1-800-670-7071.

2. Measure up from the deck/ patio floor on one side and make a mark at your desired mounting height (should be at least 7' 6"). Make a second mark 8 inches below the first mark. The space between these marks must be clear of obstructions, (light fixtures, etc) all along the length of the wall. Using a chalk line or a string, snap a level line on the lower mark for the length of the awning. The bottom of the wall brackets will rest on this lower line.

NOTE: For ease of mounting the awning into the brackets, it is very important that the line will be straight and level.

Locating the brackets

CAUTION: PROPER LOCATION OF THE BRACKETS IS THE MOST IMPORTANT ASPECT OF THE AWNING MOUNTING. IT IS CRITICAL THAT YOU FASTEN ALL THE MOUNTING BRACKETS TO STUDS, JOISTS, HEADERS OR OTHER MAJOR STRUCTURAL MEMBERS.

Even a moderate wind exerts great force on the awning and mounting brackets. This is why it is important that all the brackets will be fastened properly and securely. Proper location will also make it easier to insert the pre-assembled awning into the supporting brackets.

WARNING: FAILURE TO SECURELY FASTEN ALL THE BRACKETS TO THE WALL COULD RESULT IN THE COLLAPSE OF THE AWNING AND CAUSE PERSONAL INJURY.

NOTE: Mount brackets only in the locations recommended for your awning size. (See Figs on pages 4 and 5 for your size awning.)

NOTE: You will need to install all brackets supplied for secure mounting.

For 8ft wide awning, install two brackets supplied at the locations (b) and (f). (See Fig 1a)

For 10ft to 13ft wide awnings, install three brackets supplied at the locations (b), (d) and (f). (See Fig. 1b)

For 14ft, 15ft and 16ft wide awnings, install four brackets supplied at the locations (a), (b), (f) and (g). (See Fig. 1c)

For 17ft to 20ft wide awnings, install six brackets supplied at the locations (a), (b), (c), (e), (f) and (g). (See Fig. 1d)

Location (a) - Between the left end of the awning and the left arm, on the stud nearest to the left end.

Location (b) - Between the two arms, on the nearest stud to the left arm.

Location (c) - On the nearest stud about two feet from the middle point of the awning, toward the left.

Location (d) - The nearest stud to the middle point of the awning. (Size 10' - 13' only)

Location (e) - On the nearest stud about two feet from the middle point of the awning, toward the right.

Location (f) - Between the two arms, on the nearest stud to the right arm.

Location (g) - Between the right end of the awning and the right arm, on the stud nearest to the right end.

3. On the chalk line you have marked on the house, mark the left and right ends of the awning (points 1 and 5 in figure 1). With the exception of the 10' awning, which measures 123" left to right, all other awnings measure exactly like their defined size. (For example, a 12ft awning measures 144" from left to right.

Using your awning, measure the distance from the right end of the square bar to the inner and outer edges of the right arm clamp and record those measurements. Repeat this measurement for the left arm clamp. Mark on the chalk line the middle point and the points where the left and right arm clamps will be located (points 2, 3 and 4 in figure 1 respectively).

Note: The brackets cannot be installed in the area where the arm clamps are located.

Installing the brackets on wood frame walls w/wood, vinyl, stucco or aluminum siding

For wall mount on wood frame walls, continue with step 4.

For wall mount on masonry, brick or concrete walls, proceed to step 9.

4. YOU MUST NOW LOCATE THE STUDS, JOISTS OR HEADERS IN THE AREA IN WHICH EACH BRACKET MUST BE INSTALLED AS EXPLAINED EARLIER IN "LOCATING THE BRACKETS". If your awning is going on a wall that has a window or a door, use these steps to locate the studs inside your home and transfer those measurements to the outside. Get a roll of duct tape or similar tape. From inside your home on the wall that your awning will be installed on, place a piece (about 6" strip) of duct tape vertically on the window pane. Now using a stud finder locate a stud on the same inside wall, and mark the center of the stud. Measure from the tape or door to the center of the stud, and write the measurement down. Continue to locate the additional studs and record those measurements. On the outside wall, using the inside measurements, measure from the tape or door to the location of the center of the studs. Mark the centers of each stud on which a bracket will be installed with a 7" vertical line.

Note: For an attractive, finished appearance on Wood Siding, you can use wood spacers or shims underneath each bracket to make a flat surface. For Vinyl or Aluminum Siding, shimming beneath the siding in each bracket location may provide a more solid surface for mounting - see figure 4. Shims are not supplied with your awning.

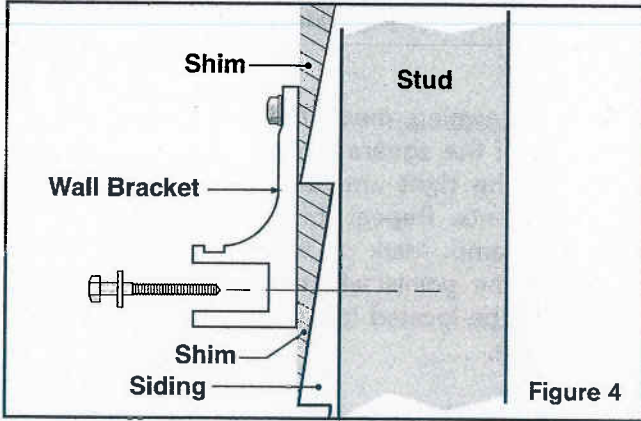

Figure 4

5. Position the bracket on the wall (or on the shim), centered over the vertical line, with the bottom of the bracket even with the lower horizontal chalk line. Using a level, plumb the bracket vertically, then mark the top and bottom holes-- see figure 5.

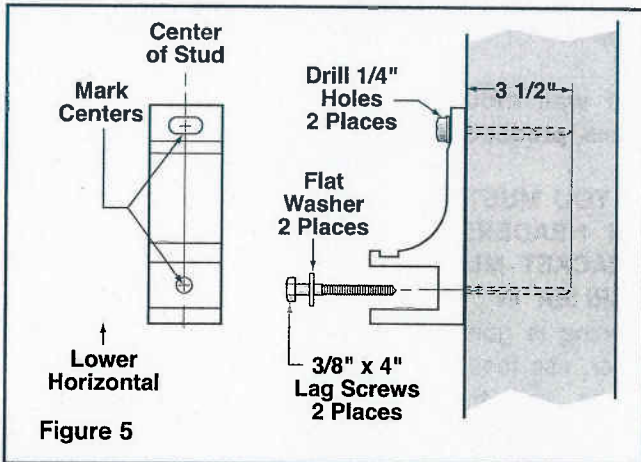

Figure 5

6. Remove the bracket and drill the top hole through the siding block or shim (if appropriate) and about 3-1/2" into the stud or joist. using a 1/4" drill bit. This will prevent the framing from splitting while installing the lag screws. Make sure the bottom hole is plumbed with the top hole, then drill the bottom hole.

7. Using a 9/16" socket, install the bracket with the two 3/8" x 4" long lag screws. Use the flat washer provided under the head of the screw. While tightening the lag screws, keep the bracket plumb (use level if needed). Do not overtighten the lag screws; doing so may split the wood framing or weaken the screw -- see figure 5.

8. Repeat for all brackets.

WARNING: YOU MUST SECURELY FASTEN ALL THE BRACKETS TO THE STUDS. SOME HOMES MAY REQUIRE LONGER LAG SCREWS. PLEASE CONSULT WITH A LOCAL HANDYMAN OR CONTRACTOR IF APPROPRIATE. FAILURE TO DO SO COULD RESULT IN COLLAPSE OF THE AWNING AND CAUSE PERSONAL INJURY.

Proceed to step 15.

Installing the brackets on masonry, brick or concrete walls

WARNING: SOME BRICK WALLS MIGHT NOT BE STRONG ENOUGH TO SAFELY SUPPORT AN AWNING. THE SUPPLIED FASTENERS ARE NOT DESIGNED TO ATTACH THE AWNING TO VINEER BRICK WALLS OR TO "SOFT BRICKS". WE SUGGEST CONSULTING A LOCAL HANDYMAN OR CONTRACTOR FOR PROPER MOUNTING.

WARNING: FAILURE TO SECURELY FASTEN BRACKETS TO THE WALL OR FAILURE OF THE WALL TO SUPPORT AN AWNING COULD RESULT IN THE COLLAPSE OF THE AWNING AND CAUSE PERSONAL INJURY.

9. Using the chart below, mark on the wall the location of the brackets and draw a 7" vertical line at each location.

Size	Loc.(a)	Loc.(b)	Loc.(c)	Loc.(d)	Loc.(e)	Loc.(f)	Loc.(g)
8ft	N/A	8" from end	N/A	N/A	N/A	8" from end	N/A
10ft	N/A	5" from end	N/A	61"	N/A	5" from end	N/A
11ft	N/A	10" from end	N/A	66"	N/A	10" from end	N/A
12ft	N/A	14" from end	N/A	72"	N/A	14" from end	N/A
13ft	N/A	20" from end	N/A	78"	N/A	20" from end	N/A
14ft	5" from end	26" from end	N/A	N/A	N/A	26" from end	5" from end
15ft	5" from end		N/A	N/A	N/A		5" from end
16ft	5" from end	} 4" from left arm clamp	N/A	N/A	N/A	} 4" from right arm clamp	5" from end
17ft	5" from end		70" from end	N/A	70" from end		5" from end
18ft	5" from end		76" from end	N/A	76" from end		5" from end
19ft	5" from end		82" from end	N/A	82" from end		5" from end
20ft	5" from end		88" from end	N/A	88" from end		5" from end

10. Position the bracket on the wall, centered over the vertical line, with the bottom of the bracket even with the lower horizontal chalk line. Using a level, plumb the bracket vertically, then mark the two holes -- see figure 6.

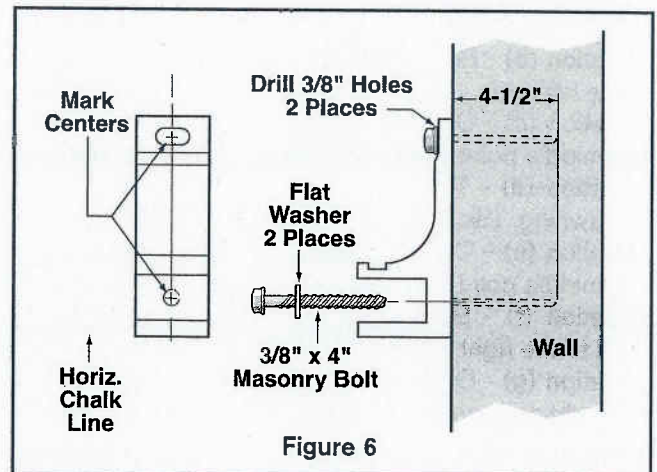

Figure 6

CAUTION: The masonry fasteners that are supplied with this awning ARE NOT designed for use in the joint between two bricks. They are ONLY to be installed within the main body of a brick, not within 1/2" of an outer edge of the brick (see figure 7). The fasteners are also not suitable for hollow cinder-block type construction or wall surfaces that have deteriorated. Consult a local hardware store for fasteners that fit these types of applications. Do not use the supplied masonry fasteners on a stucco wall.

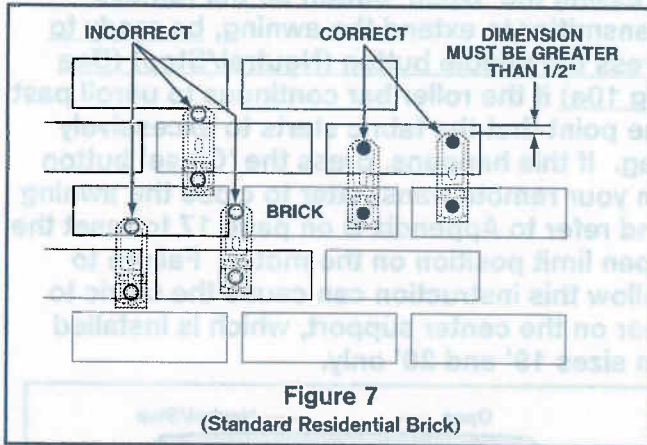

Figure 7

(Standard Residential Brick)

11. Remove the bracket and drill a 1/4" pilot hole using a masonry drill bit, about 3" deep for the top hole. Make sure the bottom hole is plumbed with the top hole, then drill the bottom hole.

12. Using the 3/8" masonry bit supplied, drill both holes 4-1/2" deep. Do not allow the holes to become tapered or oversized while drilling to this final size. **CAUTION: You must drill these holes in the two specified steps. If you do not follow these steps, the size of the hole can become too large and the bolts will not hold properly.**

13. Place a flat washer under the head of the masonry bolt and screw the bolt into the hole using a 9/16" socket - see figure 6. Repeat for other bolt. While tightening the bolts, make sure to keep the bracket plumb (use a level if needed). Do not overtighten the bolts.

WARNING: YOU MUST BE SURE THE MASONRY BOLTS ARE TIGHT IN THE HOLES. IF NOT, REMOVE THEM AND CONSULT A LOCAL HARDWARE STORE FOR FASTENERS THAT FIT YOUR APPLICATION.

14. Repeat for all brackets.

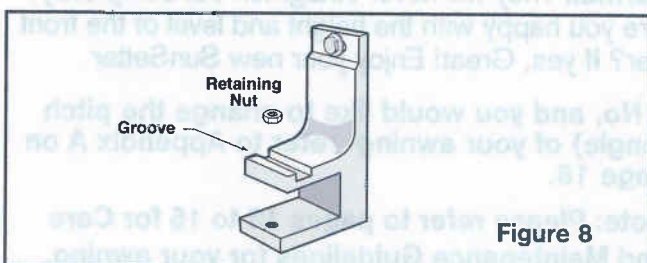

Figure 8

Securing the awning into the brackets

15. Carefully remove all packaging material from the awning. **DO NOT REMOVE THE PLASTIC SAFETY SLEEVES FROM THE ARMS.** -see Figure 10 on page 12.

Note: If you ordered the Awning Protective Cover or Aluminum Hood, it is easier to install the fasteners for the cover or brackets for the Aluminum Hood before securing the awning into the mounting brackets. Please follow the instructions included with the Protective Cover or Aluminum Hood and then resume with step 16.

16. Separate the wand from the awning.

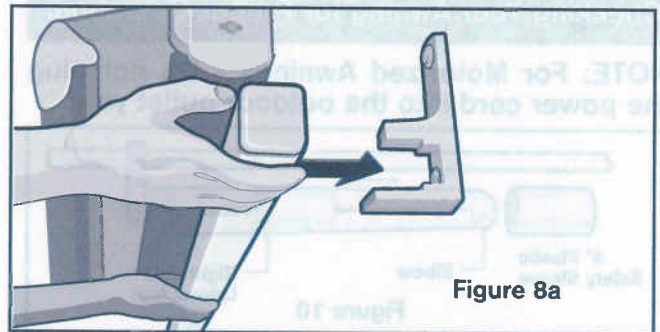

Figure 8a

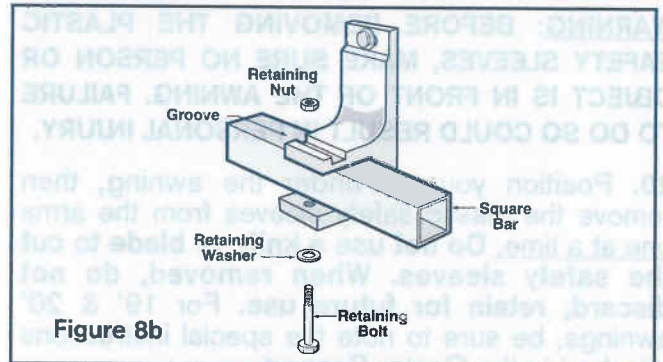

Figure 8b

17. Insert the retaining nut into the special groove in each bracket - see figure 8.

18. With the proper help, lift the awning (with fabric/roller bar above the square bar) into the brackets and position so the ends line up with end points marked on the wall -see fig. 8a. Use the following weight chart to decide how much help you need.

Size	Weight Vista	Weight Motorized	XL
8ft	65 lbs	70 lbs	x
10ft	80 lbs	85 lbs	x
11ft	85 lbs	90 lbs	x
12ft	90 lbs	95 lbs	x
13ft	95 lbs	100 lbs	x
14ft	100 lbs	110 lbs	118
15ft	105 lbs	115 lbs	123
16ft	110 lbs	120 lbs	128
17ft	115 lbs	125 lbs	133
18ft	120 lbs	130 lbs	138
19ft	n/a	135 lbs	142
20ft	n/a	140 lbs	148

19. Push the square bar into the brackets and secure with a retaining bolt in each bracket. Be sure to insert the bolt from the bottom of the bracket up. You might need to apply pressure on the square bar to permit insertion-- see Figure 8b.

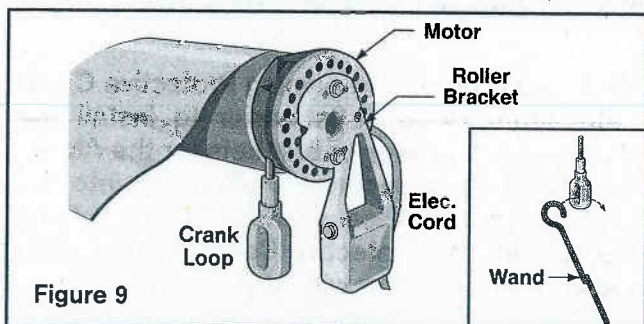

Checking Your Awning for Proper Operation.

NOTE: For Motorized Awnings - Do not plug the power cord into the outdoor outlet yet.

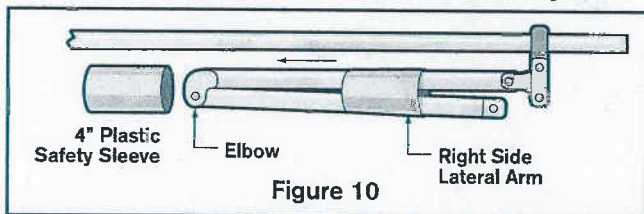

WARNING: BEFORE REMOVING THE PLASTIC SAFETY SLEEVES, MAKE SURE NO PERSON OR OBJECT IS IN FRONT OF THE AWNING. FAILURE TO DO SO COULD RESULT IN PERSONAL INJURY.

20. Position yourself under the awning, then remove the plastic safety sleeves from the arms one at a time. Do not use a knife or blade to cut the safety sleeves. When removed, do not discard, retain for future use. For 19' & 20' awnings, be sure to note the special instructions attached to the Center Support.

Motorized Awnings continue with step 21.
For Vista Awnings proceed to step 24.

21. Plug the electric cord into your outdoor ground fault receptacle.

22. We've also supplied a wall holder for the remote transmitter - see figure on page 7. Simply position the wall post at the desired location, mark the hole location and secure with the supplied hardware, if needed.

CAUTION: Do not permit the hand-held remote transmitter to get wet as this can affect its proper operation. It is recommended to install the wall holder inside the house.

Note: During an electrical outage, you can open or close your awning using the crank wand supplied. Just insert the wand into the crank loop and turn - see figure 9.

Test for Proper Operation

Note: The open and close stop limits on the awning motor were set and tested at the factory prior to shipment.

CAUTION: When opening the awning for the first time, it is very important to be sure that the Open stop setting on the motor has not been disturbed during shipment to your home. After pressing the 'Open' button on the remote transmitter to extend the awning, be ready to press the middle button (Neutral/Stop) (See Fig 10a) if the roller bar continues to unroll past the point that the fabric starts to excessively sag. If this happens, press the 'Close' button on your remote transmitter to close the awning and refer to Appendix B on page 17 to reset the open limit position on the motor. Failure to follow this instruction can cause the fabric to tear on the center support, which is installed on sizes 19' and 20' only.

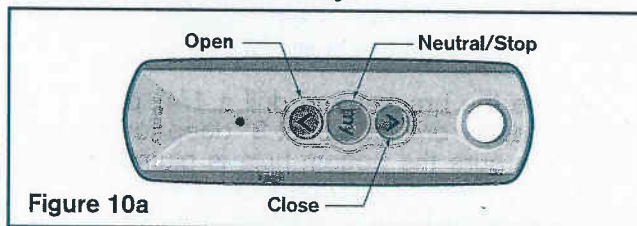

23. Test the operation of your awning by using the open and close buttons on your remote control. The awning should open to its full projection and the arms will still be bent but locked at the elbow (**this is normal**). The awning should close to about 1/2" inch between the Front Bar and the round side of the Arm Clamp (see figure 14 on page 17 of this manual).

If your awning fails to open to its full projection or does not appear to open and close properly, please follow the steps in Appendix B to reset the Open/Close Stop Limits.

Are you happy with the height and level of the Front Bar? If yes, Great! Your installation is now complete. Enjoy your new SunSetter awning.

24. VISTA Model Only: Using the crank wand, open your awning to it's full projection. The arms will still be bent but locked at the elbow. **This is normal.** They will never straighten out completely. Are you happy with the height and level of the front bar? If yes, Great! Enjoy your new SunSetter

If No, and you would like to change the pitch (angle) of your awning- refer to Appendix A on page 16.

Note: Please refer to pages 13 to 15 for Care and Maintenance Guidelines for your awning.





