

ANN ARBOR HISTORIC DISTRICT COMMISSION

Staff Report

ADDRESS: 224 South Main Street, Application Number HDC13-192

DISTRICT: Main Street Historic District

REPORT DATE: December 12, 2013

REPORT PREPARED BY: Jill Thacher, Historic Preservation Coordinator

REVIEW COMMITTEE DATE: Monday, December 9, 2013

	OWNER	APPLICANT
Name:	Jim & John Curtis Curtis Commercial LLC	Same
Address:	345 S Main Street, Suite #218 Ann Arbor, MI 48104	
Phone:	(734) 761-6170	

BACKGROUND: This one story commercial building features enameled steel panels over brick and a deeply recessed entry door with tall glass display windows. Originally a three-story Italianate structure which dated to 1860, the dry goods arm of the Mack & Co. department store moved in here 1898. The building is listed as vacant in 1942, except for Christian Mack's insurance company on the second floor of 224. The two upper stories were removed and the enameled steel panels installed on 224, which was first occupied by the Dixie Store in 1943, and the Art Moderne façade was installed on 226 for Cunningham's Drugs. They moved to this address in 1942 or 1943 from their previous storefront at 216 South Main. (All occupants per Polk City Directories.)

LOCATION: The site is located one storefront north of the northwest corner of South Main and West Liberty.

APPLICATION: The applicant seeks HDC approval to remove the enameled steel panels over the storefront windows and also install a 3' deep wood canopy with a street-facing sign band.

APPLICABLE REGULATIONS

From the Secretary of the Interior's Standards for Rehabilitation:

- (1) A property will be used as it was historically or be given a new use that requires minimal change to its distinctive materials, features, spaces, and spatial relationships.



- (2) The historic character of a property will be retained and preserved. The removal of distinctive materials or alteration of features, spaces, and spatial relationships that characterize a property will be avoided.
- (9) New additions, exterior alterations, or related new construction shall not destroy historic materials that characterize the property. The new work shall be differentiated from the old and shall be compatible with the massing, size, scale, and architectural features to protect the historic integrity of the property and its environment.

From the Secretary of the Interior's Guidelines for Rehabilitating Historic Buildings (other SOI Guidelines may also apply):

Storefronts

Recommended: Identifying, retaining, and preserving storefronts--and their functional and decorative features--that are important in defining the overall historic character of the building such as display windows, signs, doors, transoms, kick plates, corner posts, and entablatures. The removal of inappropriate, non-historic cladding, false mansard roofs, and other later alterations can help reveal the historic character of a storefront.

Designing and constructing a new storefront when the historic storefront is completely missing. It may be an accurate restoration using historical, pictorial, and physical documentation; or be a new design that is compatible with the size, scale, material, and color of the historic building.

Not Recommended: Removing or radically changing storefronts--and their features--which are important in defining the overall historic character of the building so that, as a result, the character is diminished.

Introducing a new design that is incompatible in size, scale, material, and color; using inappropriately scaled signs and logos or other types of signs that obscure, damage, or destroy remaining character-defining features of the historic building; using new illuminated signs.

From the Ann Arbor Historic District Design Guidelines:

Design Guidelines for Storefronts

Appropriate: Designing and constructing a new storefront when the historic storefront is completely missing. It may be an accurate restoration, using historical, pictorial, and physical documentation; or may be a new design that is compatible with the size, scale, and material of the historic building. New designs should be flush with the façade and be kept as simple as possible.

Not Appropriate: Installing a new storefront that is incompatible in size and material with the historic building and district.

STAFF FINDINGS

1. The enameled steel panels above the storefront windows are in poor condition, and have a number of holes and corrosion. A retractable-arm canvas awning and awning gutter

are present above the windows, but the awning is clearly deteriorated and unusable.

2. The flat wall panels have been removed, and the brick exposed, from the wall immediately to the south at 226 (and from the rest of the one-story building), which gives a decent representation of what the brick would look like under 224's panels.
3. The wooden fixed canopy proposed to be installed above the storefront windows would feature paneled ends and a paneled front sign band area. The current light box sign found on the storefront would be permanently removed as part of the project.
4. The Commission must determine whether the storefront's enameled steel panels and awning are important in defining the overall historic character of the building, or whether they are inappropriate, non-historic cladding. The panels were added during the period of significance for the district, at the same time that the building was radically altered by removing two floors. The flat wall panels have been removed from the remainder of the building – are these remaining panels an important remnant of the 1942 building fabric, or merely obscuring the underlying brick (which may date back to the 1860 building but could also be 1942 infill)?
5. The existing awning is not salvageable. If the Commission approves removal of the steel panels, staff feels that the installation of the fixed canopy is appropriate. If the steel panels are determined to be a character defining feature of the building, an awning would be more historically appropriate than a fixed canopy.

POSSIBLE MOTIONS: (Note that the motion is only a suggestion. The Review Committee, consisting of staff and at least two Commissioners, will meet with the applicant on site and then make a recommendation at the meeting.)

I move that the Commission issue a certificate of appropriateness for the application at 224 South Main Street, a contributing property in the Main Street Historic District, to allow the removal of enameled steel panels on the upper portion of the building, and install a 3' deep fixed canopy with a sign band, as proposed. The proposed work is compatible in exterior design, arrangement, texture, material and relationship to the surrounding resources and meets the *Ann Arbor Historic District Design Guidelines* and *The Secretary of the Interior's Standards for Rehabilitation and Guidelines for Rehabilitating Historic Buildings*, in particular standards 1, 2, and 9, and the guidelines for storefronts.

MOTION WORKSHEET:

I move that the Commission issue a Certificate of Appropriateness for the work at 224 South Main Street in the Main Street Historic District

_____ Provided the following condition(S) is (ARE) met: 1) STATE CONDITION(s)

The work is generally compatible with the size, scale, massing, and materials and meets the Secretary of the Interior's Standards for Rehabilitation, standard(S) number(S) (*circle all that apply*): 1, 2, 3, 4, 5, 6, 7, 8, 9, 10

ATTACHMENTS: application, drawings

224 South Main Street ("Art Gallery" -- 2007 photo)



1942 (image ©The Ann Arbor News)





City of Ann Arbor

PLANNING & DEVELOPMENT SERVICES — PLANNING SERVICES

Mailing: 301 E. Huron Street | P.O. Box 8647 | Ann Arbor, Michigan 48107-8647
Location: Larcom City Hall | First Floor | 301 E. Huron St. | Ann Arbor, MI 48104-6120
p. 734.794.6265 | f. 734.994.8312 | planning@a2gov.org

ANN ARBOR HISTORIC DISTRICT COMMISSION APPLICATION

Section 1: Property Being Reviewed and Ownership Information	
Address of Property: <u>220 S. MAIN</u>	
Historic District: <u>YES</u>	
Name of Property Owner (If different than the applicant): <u>JIM & JOHN CURTIS</u>	
Address of Property Owner: <u>343 S. MAIN ST., SUITE 218, A² MI.</u>	
Daytime Phone and E-mail of Property Owner: <u>(734)-761-6170</u>	
Signature of Property Owner: <u>[Signature]</u> Date: <u>10/10/2013</u>	
Section 2: Applicant Information	
Name of Applicant: <u>220 S. MAIN</u>	
Address of Applicant: <u>SAME</u>	
Daytime Phone: <u>SAME</u> Fax: <u>(734) 761-6170</u>	
E-mail: <u>jim@curtiscommercial.com</u>	
Applicant's Relationship to Property: <input checked="" type="checkbox"/> owner <input type="checkbox"/> architect <input type="checkbox"/> contractor <input type="checkbox"/> other	
Signature of applicant: <u>[Signature]</u> Date: <u>10/10/2013</u>	
Section 3: Building Use (check all that apply)	
<input type="checkbox"/> Residential <input type="checkbox"/> Single Family <input type="checkbox"/> Multiple Family <input type="checkbox"/> Rental	
<input checked="" type="checkbox"/> Commercial <input type="checkbox"/> Institutional	
Section 4: Stille-DeRossett-Hale Single State Construction Code Act (This item MUST BE INITIALED for your application to be PROCESSED)	
Public Act 169, Michigan's Local Historic Districts Act, was amended April 2004 to include the following language: "...the applicant has certified in the application that the property where the work will be undertaken has, or will have before the proposed completion date, a fire alarm or smoke alarm complying with the requirements of the Stille-DeRossett-Hale Single State Construction Code Act, 1972 PA 230, MCL 125.1501 to 125.1531."	
Please initial here: <u>[Signature]</u>	

100. -
cc# 3006

Section 5: Description of Proposed Changes (attach additional sheets as necessary)

1. Provide a brief summary of proposed changes. OUR OBJECTIVE IS TO CREATE A SEPARATE ENTRANCE FOR THE 1ST FLOOR RETAIL STORE WHILE ALSO REPLACING ALL GLASS & METAL TRIM WITH BRONZE ANODIZED ALUMINUM, AND THERMO GLASS.

2. Provide a description of existing conditions. IT IS VERY POORLY FINISHED AND CONFUSING. TO ENTER THE 1ST FLOOR RETAIL STORE REQUIRES ONE TO ENTER THE DOOR WHICH VISIBLY MIXES TO THE LOWER LEVEL RETAIL SPACE.

3. What are the reasons for the proposed changes? CREATE A FAR MORE ATTRACTIVE & PURPOSEFUL FRONT FOR ALL OF THE BUILDING'S TENANTS & THEIR CUSTOMERS.

4. Attach any additional information that will further explain or clarify the proposal, and indicate these attachments here.

5. Attach photographs of the existing property, including at least one general photo and detailed photos of proposed work area.

STAFF USE ONLY

Date Submitted: 10/25-2013 Application to _____ Staff or _____ HDC

Project No.: HDC 13-191 Fee Paid: 100⁰⁰

Pre-filing Staff Reviewer & Date: _____ Date of Public Hearing: 12/12-2013

Application Filing Date: _____ Action: _____ HDC COA _____ HDC Denial

Staff signature: _____ _____ HDC NTP _____ Staff COA

Comments:

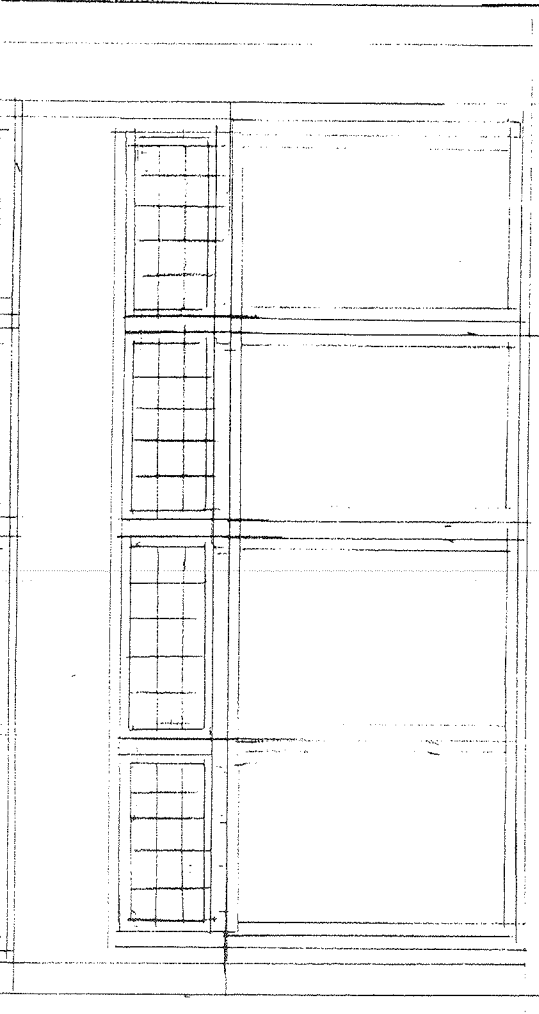

ART GALLERY
PICTURE FRAMING

THE PHOENIX CENTER

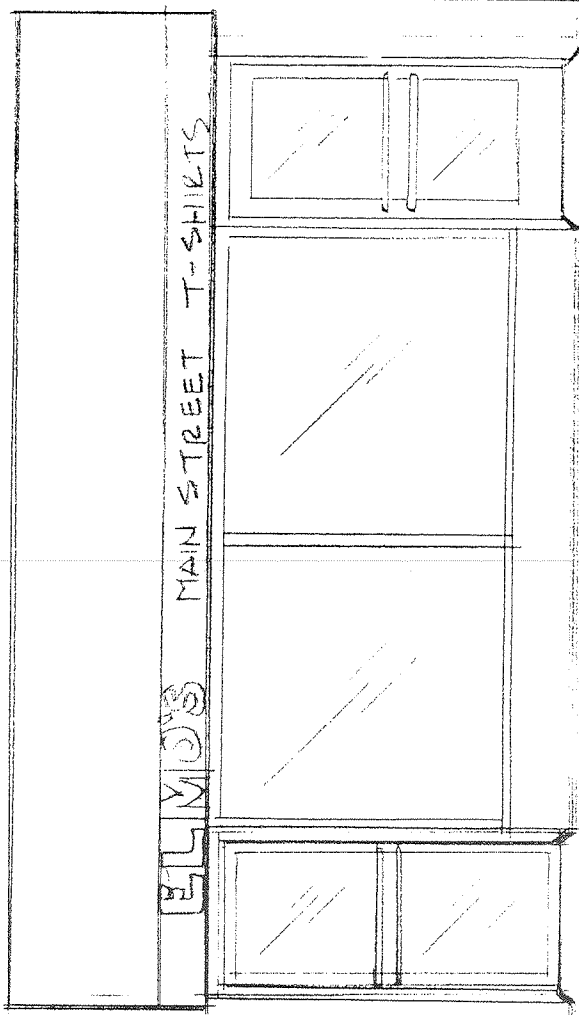

220 S. MAIN

224 S. MAIN



EXISTING FRONT ELEVATION 9.6.13

SCALE IN FEET 0

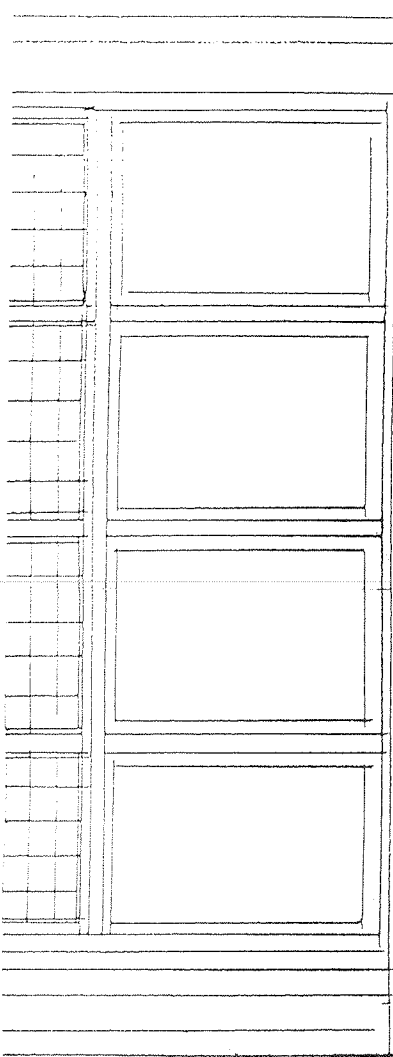

INSTALL VERTICAL TRIM-MATERIAL T.B.P. EITHER 1X8 OR 1X10"

REMOVE FACING PANELS- REPAIR & CLEAN EXISTING BRICK & PAINT

THE PHOENIX CENTER

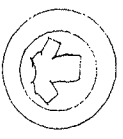

REMAIN

NEW TENANT SIGNAGE PANEL



ELMO'S MAIN STREET T-SHIRTS

224 S. MAIN

220 S. MAIN

W/O 12" JAMB

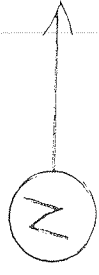

PROPOSED FRONT ELEVATION

SCALE 1/4" = 1'-0"

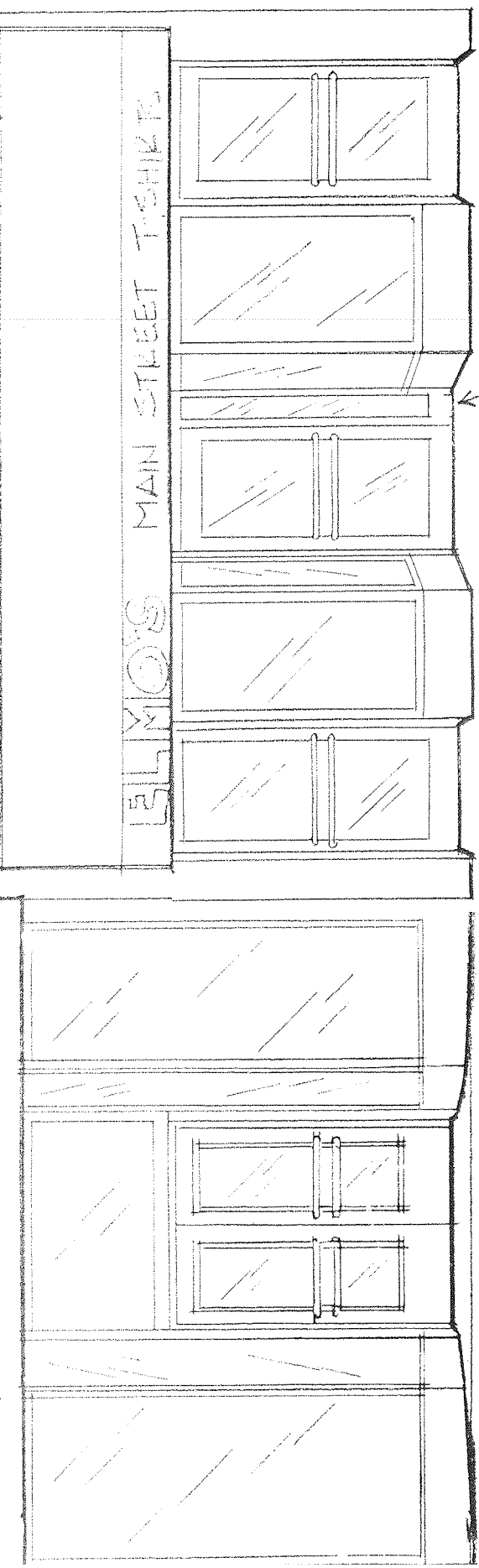

224 S. MAIN

12' SIDELIGHT

220 S. MAIN

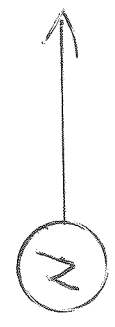
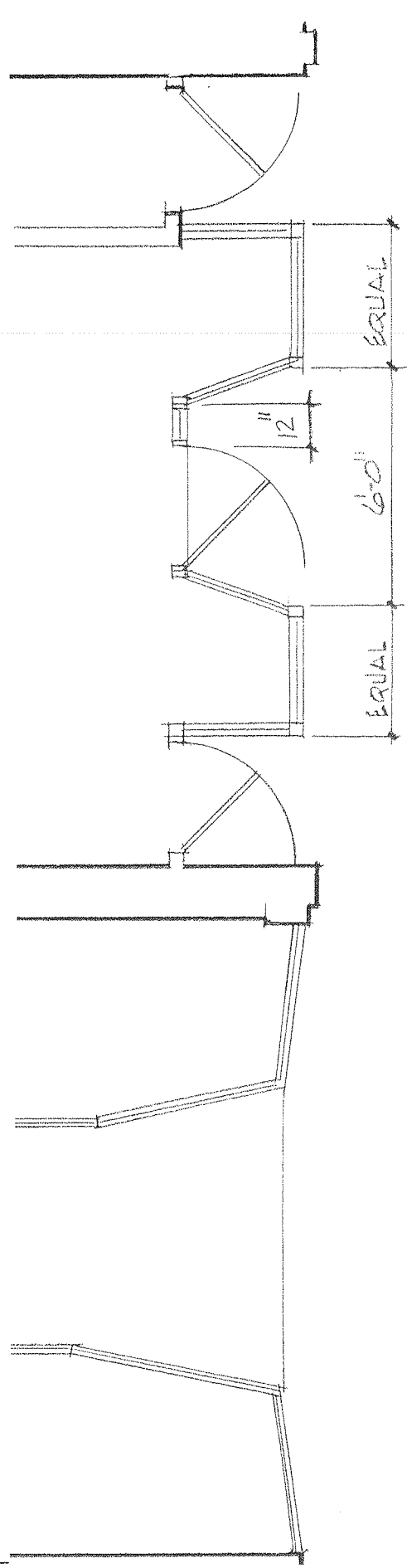

OFF-CENTER DOOR W/ 12" ADA JAMB SPACE

224 & 220 S. MAIN

SCALE IN FEET

0 1 2 3 4 5

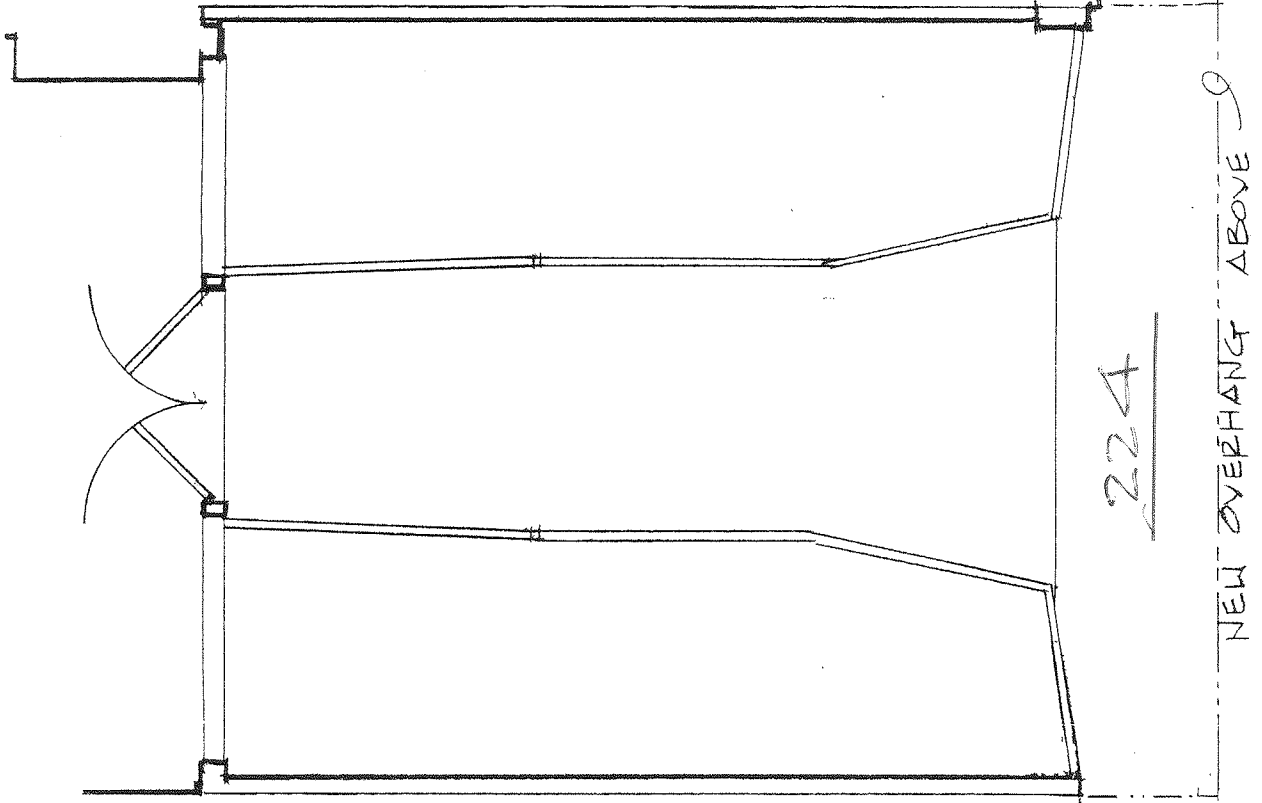

DEP
REP.

REMOVE DOORWAY,
FILL OPQ. TO MATCH

w/o 12" JAMBS

NEW ENTRY
IN-LINE W/
EXISTING

EXISTING
PR.

EXISTING
DOOR

NEW
INSUL
GLASS

224

NEW OVERHANG ABOVE

EQUAL

6'-0"

REMOVE
RECESS

EQUAL

EXISTING
NEW

EXISTING CANOPY ABOVE

PROPOSED FLOOR PLAN • 9-6-13

224 & 220 S. MAIN

SCALE IN FEET

0 1 2 3 4 5