

ANN ARBOR HISTORIC DISTRICT COMMISSION

Staff Report

ADDRESS: 601 East Liberty Street, Application Number HDC14-125

DISTRICT: State Street Historic District

REPORT DATE: July 10, 2014

REPORT PREPARED BY: Jill Thacher, Historic Preservation Coordinator

REVIEW COMMITTEE DATE: July 7, 2014

| OWNER | APPLICANT |
|---|---|
| Name: TC Ann Arbor LLC | Angela Lane |
| Address: Attn: Thomas C. White 801 S. Adams Road, Suite 205 Birmingham, MI 48009 | 106 South Main Street Ann Arbor, 48104 |
| Phone: (248) 568-1793 | (734) 996-8899 |

BACKGROUND: This two-story commercial building is part of the east wing of the Michigan Theater Building. It was built in 1927 in the 20th Century Romanesque style, though it has undergone significant alteration. The storefront is now mainly glass, framed in mill finish silver aluminum, with a low ashlar limestone sill and a few vertical panels of dark marble. The sign band area used to be a transom with leaded glass blocks. On the second floor are four deeply-inset windows flanked by Corinthian pilasters, with half-circle arches on top and inset blue and green tiles.

LOCATION: The site is located on the north side of East Liberty Street, directly across from the intersection of East Liberty Street and Maynard Street to the south.

APPLICATION: The applicant seeks HDC approval to install a new externally illuminated business sign, remove an awning, replace the aluminum storefront window/door system with a new aluminum system, and replace the limestone sill and green marble with yellow brick compatible with the theater building.

APPLICABLE REGULATIONS

From the Secretary of the Interior's Standards for Rehabilitation:

- (1) A property will be used as it was historically or be given a new use that requires minimal change to its distinctive materials, features,

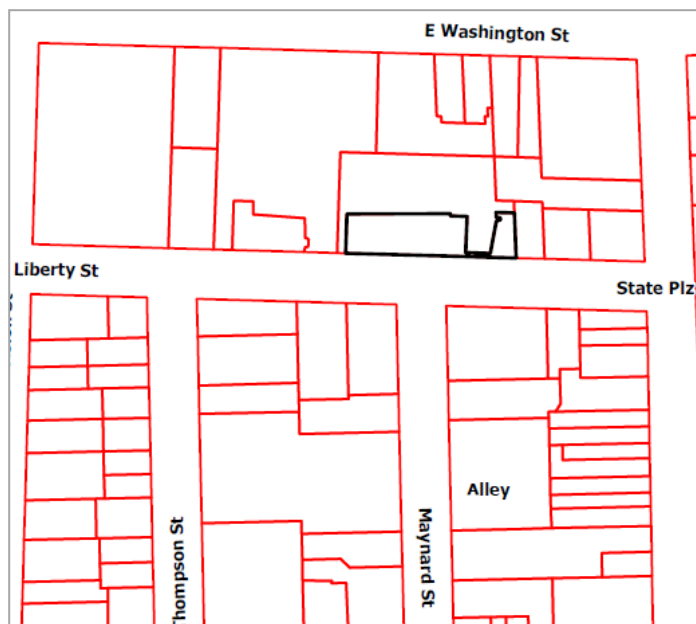

spaces, and spatial relationships.

- (2) The historic character of a property will be retained and preserved. The removal of distinctive materials or alteration of features, spaces, and spatial relationships that characterize a property will be avoided.
- (5) Distinctive materials, features, finishes, and construction techniques or examples of craftsmanship that characterize a property will be preserved.
- (9) New additions, exterior alterations, or related new construction shall not destroy historic materials that characterize the property. The new work shall be differentiated from the old and shall be compatible with the massing, size, scale, and architectural features to protect the historic integrity of the property and its environment.

From the Secretary of the Interior's Guidelines for Rehabilitating Historic Buildings (other SOI Guidelines may also apply):

Storefronts

Recommended: Identifying, retaining, and preserving storefronts--and their functional and decorative features--that are important in defining the overall historic character of the building such as display windows, signs, doors, transoms, kick plates, corner posts, and entablatures. The removal of inappropriate, non-historic cladding, false mansard roofs, and other later alterations can help reveal the historic character of a storefront.

Designing and constructing a new storefront when the historic storefront is completely missing. It may be an accurate restoration using historic, pictorial, and physical documentation; or be a new design that is compatible with the size, scale, material, and color of the historic building.

Not Recommended: Removing or radically changing storefronts--and their features--which are important in defining the overall historic character of the building so that, as a result, the character is diminished.

Introducing a new design that is incompatible in size, scale, materials, and color; using inappropriately scaled signs and logos or other types of signs that obscure, damage, or destroy remaining character-defining features of the historic building; using new illuminated signs.

From the Ann Arbor Historic District Design Guidelines:

Design Guidelines for Storefronts

Appropriate: Protecting, maintaining and preserving storefronts and their functional and decorative features that are important in defining the overall historic character of the building such as display windows, signs, doors, transoms, kick plates, corner posts, and entablatures using recognized preservation methods

Designing and constructing a new storefront when the historic storefront is completely missing. It may be an accurate restoration using historic, pictorial, and physical

documentation; or be a new design that is compatible with the size, scale, material, and color of the historic building. New designs should be flush with the façade and be kept as simple as possible.

Not Appropriate: Installing a new storefront that is incompatible in size and material with the historic building and district.

Removing or radically changing storefronts and their features which are important in defining the overall historic character of the building so that the character is diminished.

Design Guidelines for Signs

Appropriate: Attaching signage through masonry joints, not masonry units, or through materials that can be easily repaired, such as wood, when the signage is removed.

Installing signage that is subordinate to the overall building composition.

Placing signs to align with others along the commercial block face.

Attaching signage through masonry joints, not masonry units, or through materials that can be easily repaired, such as wood, when the signage is removed.

STAFF FINDINGS

1. The proposed changes to this non-original storefront are simple and should not detract from the ornate upper floor or the Michigan Theater lobby next door. The use of light-colored brick on the sill and sidewall are much more compatible than the existing limestone and green marble. The dark bronze aluminum door and 2" window framing work well with the proposed black sign band and the black marquee face next door at the theater.
2. There may be a glass block transom above the storefront, and staff advises the applicant to use great caution in removing the existing sign band. If any part of that transom is still extant, the new sign band must be installed in a way that does no harm to it. This condition is included in the proposed motion.
3. The sign is an appropriate size and design, and the lighting is accomplished by two small 5 ½" long fixtures on 24" arms.
4. Staff believes that the work as conditioned is complementary and appropriate for this storefront and the larger building. The work meets the *Ann Arbor Historic District Design Guidelines* and the *Secretary of the Interior's Guidelines*, and the *Secretary of the Interior's Standards for Rehabilitation*.

POSSIBLE MOTIONS: (Note that the motion is only a suggestion. The Review Committee, consisting of staff and at least two Commissioners, will meet with the applicant on site and then make a recommendation at the meeting.)

I move that the Historic District Commission issue a certificate of appropriateness for the application at 601 East Liberty Street, a contributing property in the State Street Historic District, to make the proposed changes to the exterior of the building ON THE CONDITION that no historic materials are harmed, including behind the sign band. The work as conditioned is compatible in exterior design, arrangement, texture, material and relationship to the surrounding resources and meets the *Ann Arbor Historic District Design Guidelines*

and *The Secretary of the Interior's Standards for Rehabilitation and Guidelines for Rehabilitating Historic Buildings*, in particular standards 1, 2, 5, and 9, and both sets of guidelines for storefronts.

MOTION WORKSHEET:

I move that the Historic District Commission issue a Certificate of Appropriateness for the work at 601 East Liberty Street in the State Street Historic District

_____ Provided the following condition(S) is (ARE) met: 1) STATE CONDITION(s)

The work is generally compatible with the size, scale, massing, and materials and meets the Secretary of the Interior's Standards for Rehabilitation, standard(S) number(S) (*circle all that apply*): 1, 2, 3, 4, 5, 6, 7, 8, 9, 10

ATTACHMENTS: application, drawings, photos

601 East Liberty Street (Google Street View 2012)



Photo from the Michigan Theater website, c.1935



Michigan Theater, 1929 (Bentley Historical Library)





City of Ann Arbor

PLANNING & DEVELOPMENT SERVICES — PLANNING SERVICES

Mailing: 301 E. Huron Street P.O. Box 8647 Ann Arbor, Michigan 48107-8647
Location: Larcom City Hall First Floor 301 E. Huron St. Ann Arbor, MI 48104-6120
734.794.6265 734.994.8312 planning@a2gov.org

ANN ARBOR HISTORIC DISTRICT COMMISSION APPLICATION

Section 1: Property Being Reviewed and Ownership Information

Address of Property: 601 E LIBERTY

Historic District: STATE STREET

Name of Property Owner (If different than the applicant):

TC ANN ARBOR LLC ATTN: THOMAS C. WHITE

Address of Property Owner: 801 S. ADAMS RD, SUITE 205 BIRMINGHAM, MI 48009

Daytime Phone and E-mail of Property Owner: 248 568 1793

* Signature of Property Owner: [Signature] Date: June 19/14

Section 2: Applicant Information

Name of Applicant: ANGELA LANE

Address of Applicant: 106 S. MAIN, ANN ARBOR

Daytime Phone: (734) 998 0098 Fax: (734) 996 8899

E-mail: angie@mamusinc.com

Applicant's Relationship to Property: owner architect contractor other

Signature of applicant: [Signature] Date: 6/19/14

Section 3: Building Use (check all that apply)

Residential Single Family Multiple Family Rental

Commercial Institutional

Section 4: Stille-DeRossett-Hale Single State Construction Code Act

(This item **MUST BE INITIALED** for your application to be **PROCESSED**)

Public Act 169, Michigan's Local Historic Districts Act, was amended April 2004 to include the following language: "... the applicant has certified in the application that the property where the work will be undertaken has, or will have before the proposed completion date, a fire alarm or smoke alarm complying with the requirements of the Stille-DeRossett-Hale Single State Construction Code Act, 1972 PA 230, MCL 125.1501 to 125.1531."

Please initial here: AL

Section 5: Description of Proposed Changes (attach additional sheets as necessary)

1. Provide a brief summary of proposed changes. Removal of previous tenant's signage, replace non original storefront windows, stone & awning

2. Provide a description of existing conditions. exposed area where previous sign was taken down, aluminum storefront & mis-matched green marble (non original) & prairie style stone (non original)

3. What are the reasons for the proposed changes? to give the facade a cohesive appearance relating to the existing brick above storefront level

4. Attach any additional information that will further explain or clarify the proposal, and indicate these attachments here. see attached photos & renderings

5. Attach photographs of the existing property, including at least one general photo and detailed photos of proposed work area.

STAFF USE ONLY

Date Submitted: _____ Application to _____ Staff or _____ HDC

Project No.: _____ HDC _____ Fee Paid: _____

Pre-filing Staff Reviewer & Date: _____ Date of Public Hearing: _____

Application Filing Date: _____ Action: _____ HDC COA _____ HDC Denial

Staff signature: _____ _____ HDC NTP _____ Staff COA

Comments:

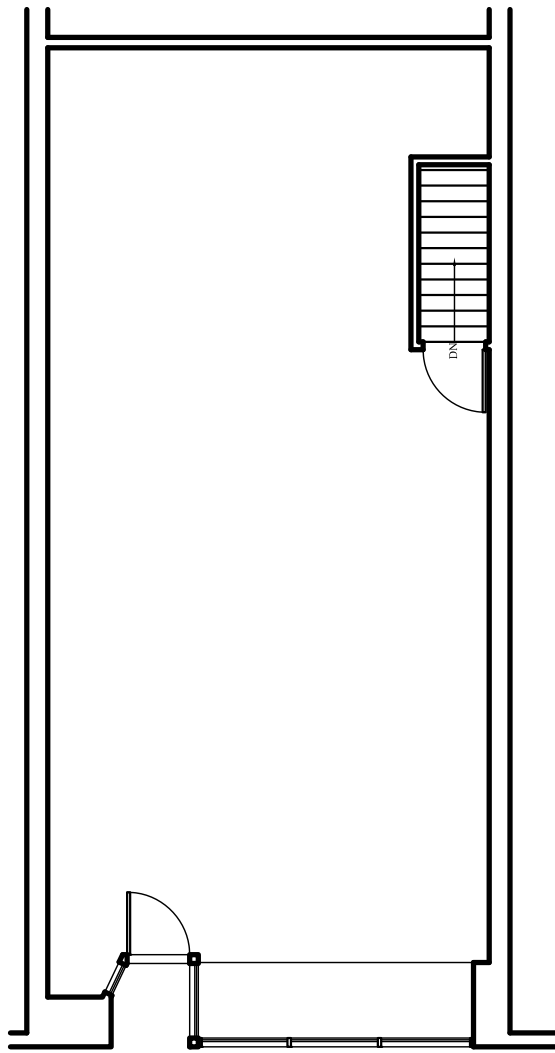

FLOOR PLAN

N.T.S.

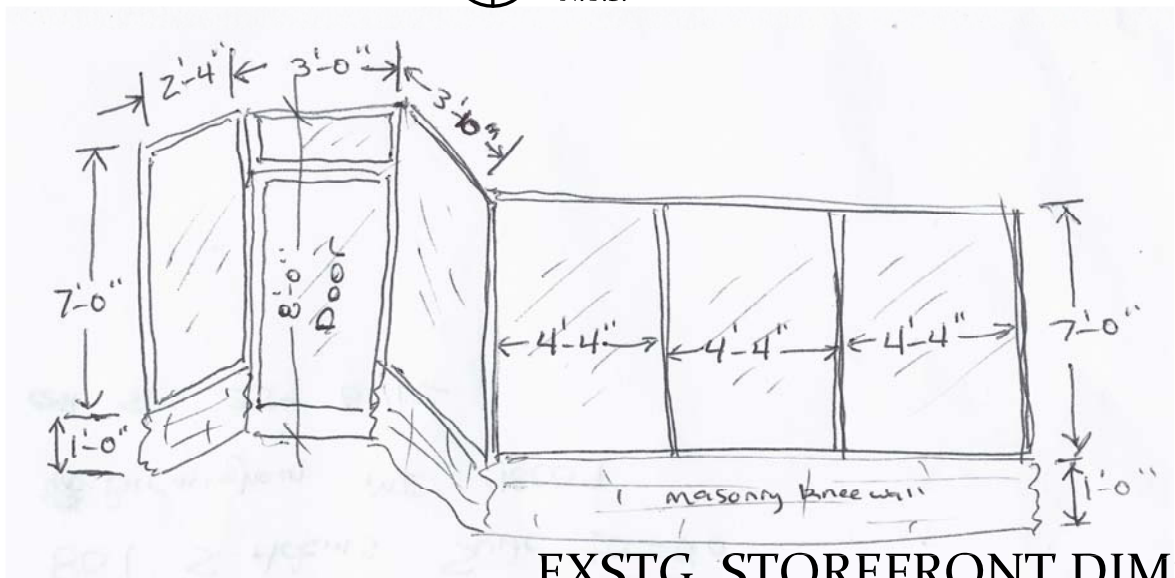

EXSTG. STOREFRONT DIMS.

N.T.S.

| | | |
|----------------|--|---------------------------|
| PROJECT | TAYLOR & COLT 601 E. LIBERTY ANN ARBOR, MI | DATE JUNE 18, 2014 |
|----------------|--|---------------------------|

| | |
|---|---|
|  | 106 S. MAIN STREET ANN ARBOR, MICHIGAN 48104 |
|---|---|



EXISTING EXTERIOR

N.T.S.

PROJECT

TAYLOR & COLT 601 E. LIBERTY ANN ARBOR, MI

DATE JUNE 18, 2014



106 S. MAIN STREET
ANN ARBOR, MICHIGAN 48104

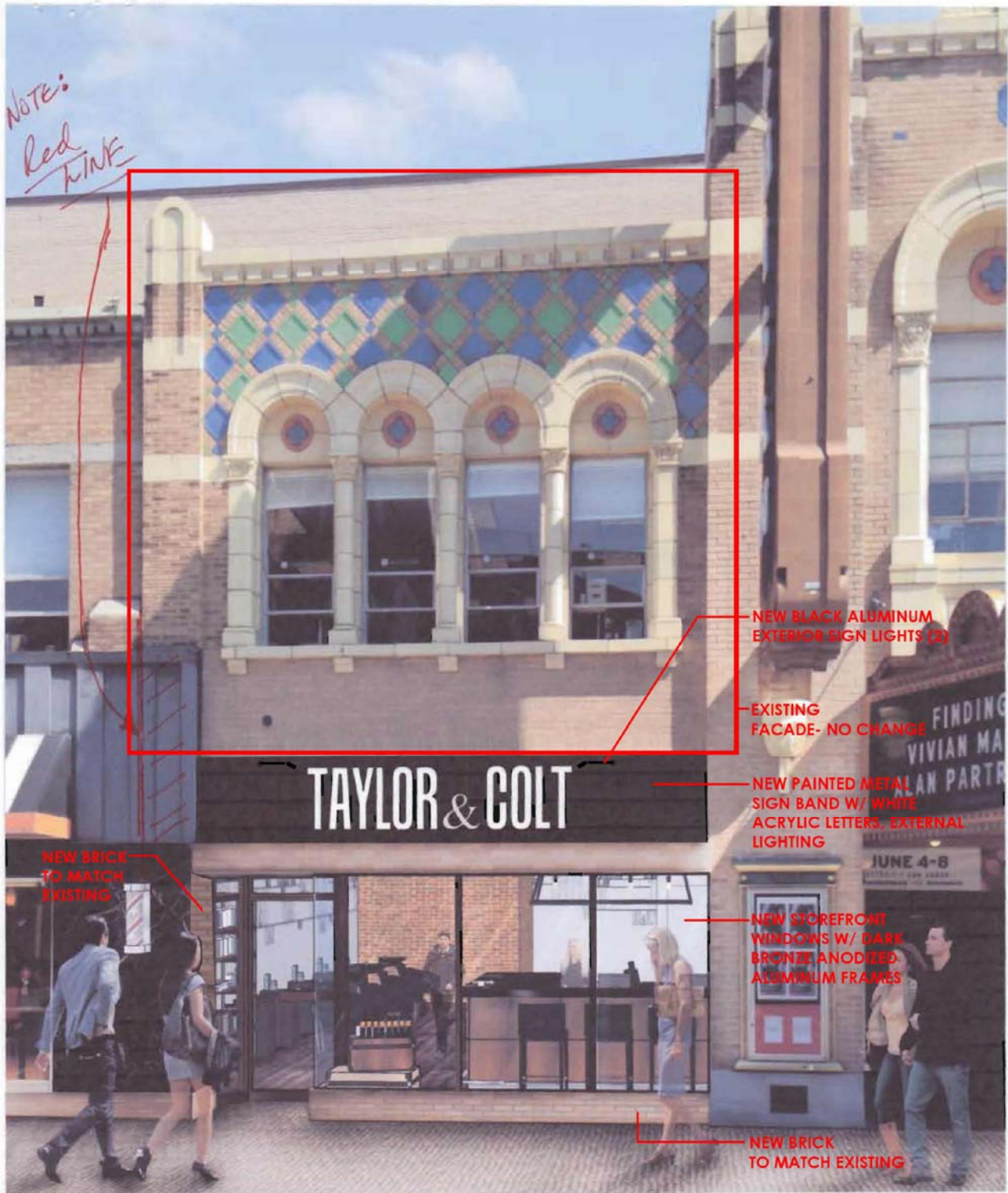

SIGN: 41 SQ. FT (44s.f. allowed, 2s.f. per lineal foot of frontage)
 3 MESSAGE UNITS (10 allowed)



PROPOSED EXTERIOR

N.T.S.

| | | |
|----------------|--|---------------------------|
| PROJECT | TAYLOR & COLT 601 E. LIBERTY ANN ARBOR, MI | DATE JUNE 18, 2014 |
|----------------|--|---------------------------|



106 S. MAIN STREET
 ANN ARBOR, MICHIGAN 48104

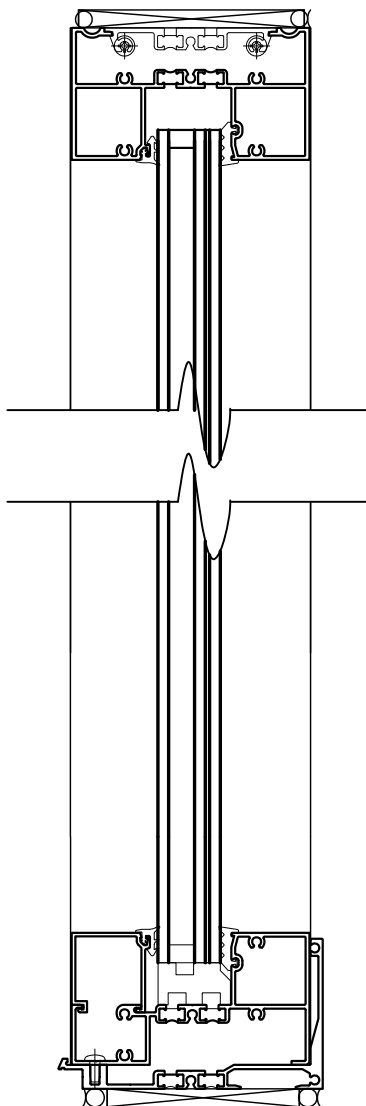

2" DARK BRONZE ANODIZED ALUMINUM STOREFRONT FRAMES W/ 1" GLASS. ATTACHED TO EXSTG. LINTEL & SILL PLATE AS REQ'D. REPLACE ANY UNSUITABLE EXSTG. FRAMING AS NEC., PROVIDE NEW CONT. CAULK AT WINDOW JOINTS

WINDOW FRAME DETAIL

SCALE 3" = 1'-0"

PROJECT

TAYLOR & COLT 601 E. LIBERTY ANN ARBOR, MI

DATE

JUNE 18, 2014



106 S. MAIN STREET
ANN ARBOR, MICHIGAN 48104

1

+/- 18'-4"



Front View

+/- 2'-3"

3"



Side View

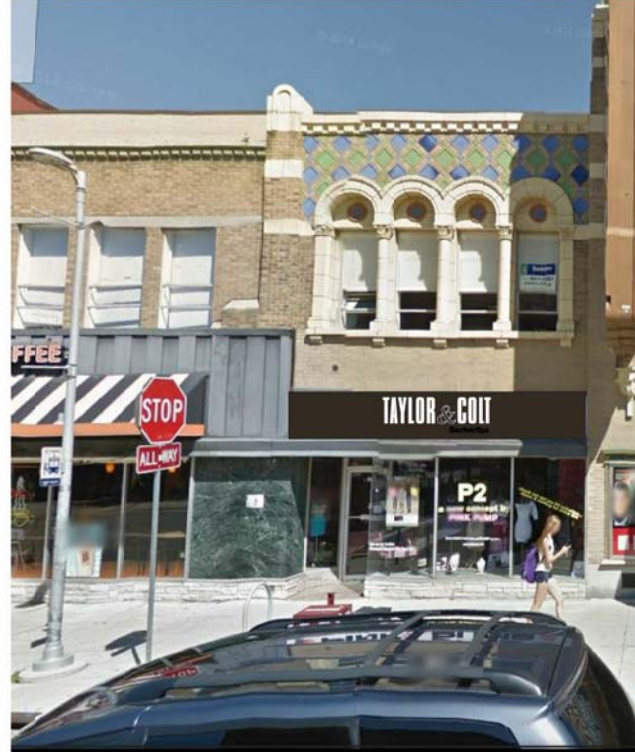

Sign 1

Supply and install 1 new s/f illuminated exterior display

Graphics / Substrate
"TAYLOR" and "COLT"

"BarberSpa"

Illumination

EXTERNAL BY G.C.

Construction

Paint

All exposed metal painted black

Notes

1) Supply vents and drain holes as required

- White 7328 Acrylic
- Black 3635-222 Dual Colour Vinyl
- Brushed Aluminum Paint

S:\T\Taylor and Colt\Ann Arbor - Michigan\S0018236

| | | | | | | | | | |
|---------------------------------------|--|---------|---------------|----------|------------|-----------------------|---------------|--|---|
| www.zipsigns.com | | Client | Taylor&Colt | Dwg No. | So018236 | Date | June 12, 2014 | <input checked="" type="checkbox"/> CONCEPTUAL NOT FOR CONSTRUCTION | <input type="checkbox"/> SHOP READY CONSTRUCTION CAPABLE |
| 5040 North Service Rd. Burlington, ON | | Address | | Designer | CH | Rev. | | Scale: | Page: 1 of |
| Ph. 905-332-8332 Fax 905-332-9994 | | | Ann Arbor, MI | Sales | Craig Hall | SALES REP SIGN OFF | | | |



SIGN DETAIL

N.T.S.

| | | | |
|----------------|--|-------------|---------------|
| PROJECT | TAYLOR & COLT 601 E. LIBERTY ANN ARBOR, MI | DATE | JUNE 18, 2014 |
|----------------|--|-------------|---------------|



106 S. MAIN STREET
ANN ARBOR, MICHIGAN 48104

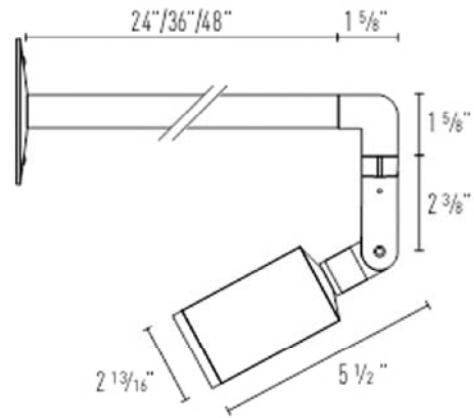

Order Matrix | Example: IVT103B-48

| A | B | C | D |
|--|--|---|---|
| A Series | | C Stem Length | |
| IVT103 | MR16 Straight Arm Sign Lighter Low Voltage | -24 24" Stem Length -36 36" Stem Length -48 48" Stem Length | |
| B Finish | | D Accessories | |
| W White Aluminum B Black Aluminum BR Bronze Aluminum | | -IPV100 45° Cutoff Directional Shield | |



Triple Media Lens Holder

For use with up-to (3) 1 5/8" filters. Accepts one diffusion filter media and two color filters or louvers.

LH3 | (3) Media Lens Holder

Filter Media:

| | |
|----------|------------------------|
| PFL1-S | Prismatic Spread Lens |
| PFL2-S | Linear Spread Lens |
| PFL3-S | Sand Blast Spread Lens |
| PFL4-S | Soft Focus |
| PFL7-S | UV Filter |
| PFL16B-S | Black Hex Louver |

Color Media:

| | |
|-------|--------|
| PL5-S | Amber |
| PL6-S | Red |
| PL7-S | Yellow |
| PL8-S | Green |
| PL9-S | Blue |



IPV100

45° Cutoff Directional Shield

Accessories:

LH3: Lens cap accommodates accessory holder. Allows the use of up-to (3) 1 5/8" media/color filters. Filters must be ordered separately.

IPV100: Directional shield provides 45° cutoff. Available in aluminum or stainless steel. Specify at the end of part number. Factory installed.

Listing:

ETL listed for wet locations. ETL listed to US and Canadian standards.

Lamp:

12V MR16 50W max.

Socket:

GU5.3

Features:

- Available in white, black or bronze die-cast aluminum. Custom finishes available by special order. Consult factory.
- 1" diameter machined aluminum stem with 1/2" NPT threads at each end.
- Stem lengths available in 24", 36" and 48" lengths
- 90° adapter provides transition from fixture to stem.
- High temperature silicone O-ring provides water tight seal.
- Easy lamp replacement with lamp cover secured by a flush tamper-proof set screw.
- Integral knuckle provides 196° of vertical aiming and 360° of horizontal rotation. Tamper proof screws ensure precise aiming.
- Lamp cover is sealed with a static O-ring. Tempered glass lens is standard.
- 1/2" pipe thread for mounting to junction box (by others) or included Intense canopy.

Installation:

Machined aluminum canopy mounts to standard 3 1/2" octagon junction box. 120V input 12V output transformer included.

Integral Wiring:

18AWG Teflon coated wire 600V 250°C.

Finish:

Die-cast aluminum available in white, black or bronze powder coat. Custom finishes available by special order. Consult factory.

Hardware:

Stainless steel tamper-proof screws are flush mounted. Set of allen keys included with every fixture.

PROJECT

TAYLOR & COLT 601 E. LIBERTY ANN ARBOR, MI

DATE

JUNE 18, 2014



106 S. MAIN STREET
ANN ARBOR, MICHIGAN 48104